

DRAWING FOR REFERENCE: This is subject to change without notice
08/11/2012

| |
|----|
| TO |
| |
| |
| |

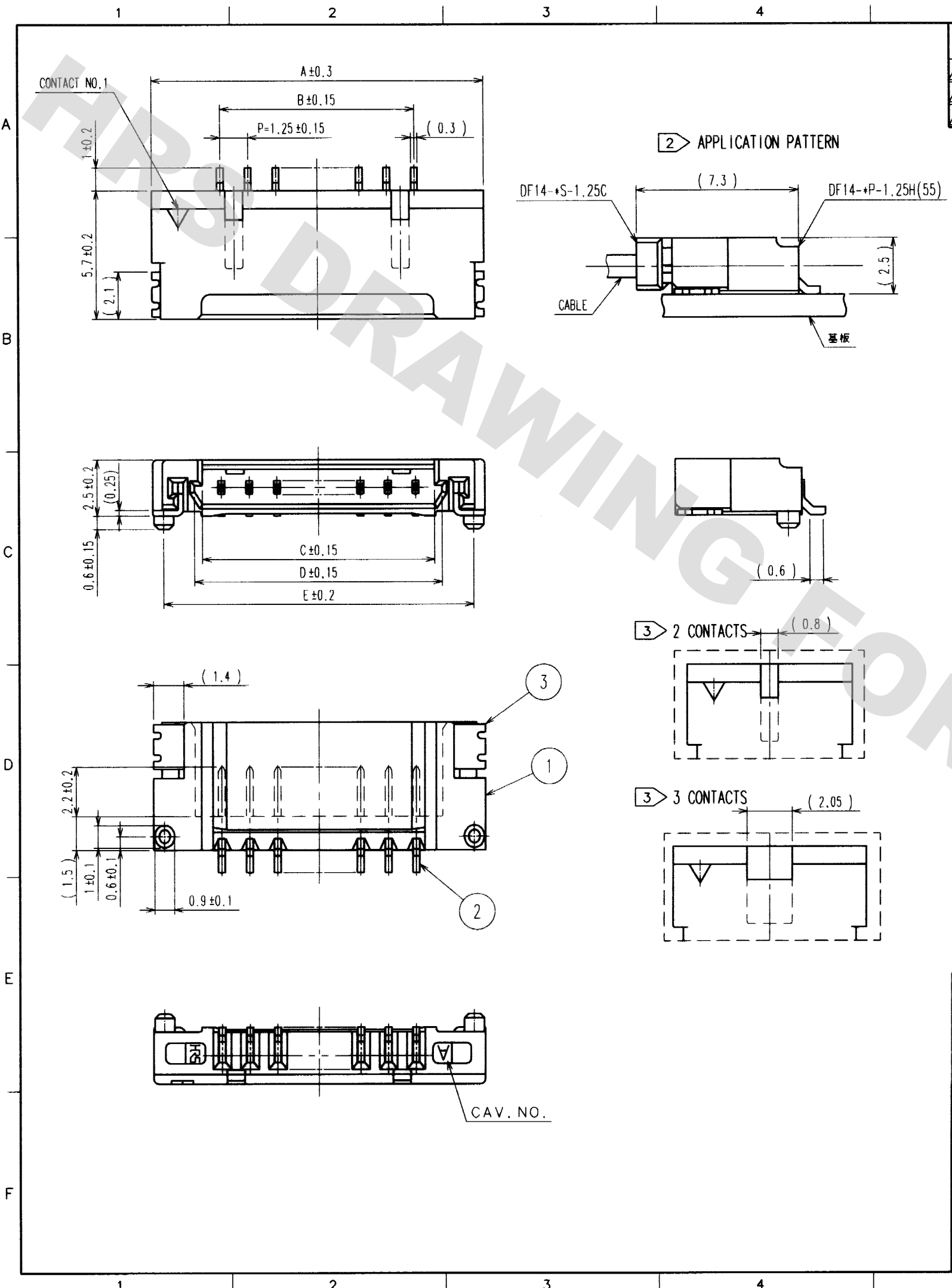

| COUNT | DESCRIPTION OF REVISIONS | BY | CHKD | DATE | COUNT | DESCRIPTION OF REVISIONS | BY | CHKD | DATE |
|-------|--------------------------|----|------|------|-------|--------------------------|----|------|------|
| | | | | | | | | | |
| | | | | | | | | | |
| | | | | | | | | | |

| PART NO. | HRS NO. | CONTACTS | A | B | C | D | E | F |
|--------------------|-----------------|----------|-------|-------|-------|-------|-------|-------|
| DF14- 2P-1.25H(55) | CL538-0021-4-55 | 2 | 7.45 | 1.25 | 2.95 | 3.65 | 6.45 | 8.05 |
| DF14- 3P-1.25H(55) | CL538-0022-7-55 | 3 | 8.70 | 2.50 | 4.20 | 4.90 | 7.70 | 9.30 |
| DF14- 4P-1.25H(55) | CL538-0023-0-55 | 4 | 9.95 | 3.75 | 5.45 | 6.15 | 8.95 | 10.55 |
| DF14- 5P-1.25H(55) | CL538-0024-2-55 | 5 | 11.20 | 5.00 | 6.70 | 7.40 | 10.20 | 11.80 |
| DF14- 6P-1.25H(55) | CL538-0025-5-55 | 6 | 12.45 | 6.25 | 7.95 | 8.65 | 11.45 | 13.05 |
| DF14- 7P-1.25H(55) | CL538-0026-8-55 | 7 | 13.70 | 7.50 | 9.20 | 9.90 | 12.70 | 14.30 |
| DF14- 8P-1.25H(55) | CL538-0027-0-55 | 8 | 14.95 | 8.75 | 10.45 | 11.15 | 13.95 | 15.55 |
| DF14- 9P-1.25H(55) | CL538-0028-3-55 | 9 | 16.20 | 10.00 | 11.70 | 12.40 | 15.20 | 16.80 |
| DF14-10P-1.25H(55) | CL538-0029-6-55 | 10 | 17.45 | 11.25 | 12.95 | 13.65 | 16.45 | 18.05 |
| DF14-15P-1.25H(55) | CL538-0084-4-55 | 15 | 23.70 | 17.50 | 19.20 | 19.90 | 22.70 | 24.30 |
| DF14-20P-1.25H(55) | CL538-0089-8-55 | 20 | 29.95 | 23.75 | 25.45 | 26.15 | 28.95 | 30.55 |
| DF14-25P-1.25H(55) | CL538-0094-8-55 | 25 | 36.20 | 30.00 | 31.70 | 32.40 | 35.20 | 36.80 |
| DF14-30P-1.25H(55) | CL538-0020-1-55 | 30 | 42.45 | 36.25 | 37.95 | 38.65 | 41.45 | 43.05 |

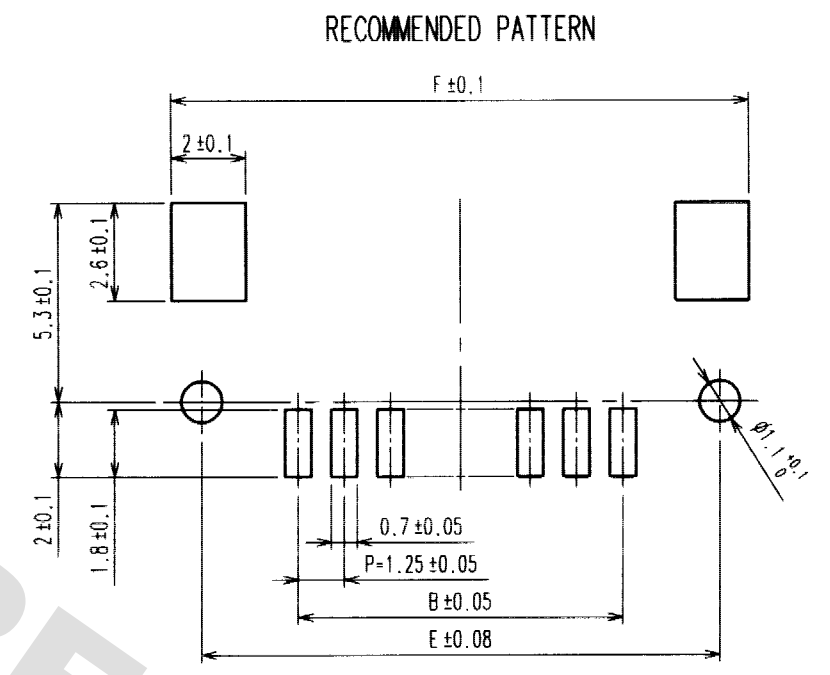

NOTE 1. LEAD CO-PLANALITY INCLUDE REINFORCED METAL FITTING SHALL BE 0.1 MAX.
 2. WHEN THIS CONNECTOR MATES WITH DF14-*S-1.25C, THE MATTING LENGTH IS 7.3mm.
 3. FOR CONNECTORS, 2 OR 3 CONTACTS, SIMPLIFIED LOCK HOLE SHALL BE SET AT THE CENTER OF HOUSING.

| 2 | BRASS | CONTACT AREA: GOLD PLATED 0.1μm min LEAD AREA: TIN-COPPER PLATED 1μm min UNDER PLATING: NICKEL PLATED 1μm min | 5 | S. PVC | |
|-----|-----------|---|-----|---------------------|---|
| 1 | POLYAMIDE | BEIGE, UL94V-0 | 4 | RIGID VINYLCHLORIDE | ELECTROSTATIC PROTECTION |
| | | | 3 | PHOSPHOR BRONZE | TIN-COPPER PLATED 1μm min UNDER PLATING: NICKEL PLATED 0.5μm min |
| NO. | MATERIAL | FINISH, REMARKS | NO. | MATERIAL | FINISH, REMARKS |

| CODE NO. (OLD) | DRAWN | DESIGNED | CHECKED | APPROVED | RELEASED |
|----------------|--------------------|--------------------|--------------------|--------------------|----------|
| CL | <i>F. Mitsuiki</i> | <i>S. Dampunya</i> | <i>T. Miyazaki</i> | <i>T. Miyazaki</i> | |
| | 03.3.5 | 03.3.7 | 03.03.10 | 03.03.10 | |

| | | |
|-------|----------------|-------------------|
| SCALE | DRAWING NO. | PART NO. |
| 5 : 1 | EDC3-160307-20 | DF14-*P-1.25H(55) |
| UNITS | CODE NO. | |
| mm | CL538- | |



| COUNT | DESCRIPTION OF REVISIONS | BY | CHKD | DATE | COUNT | DESCRIPTION OF REVISIONS | BY | CHKD | DATE |
|-------|--------------------------|----|------|------|-------|--------------------------|----|------|------|
| △ | | | | | △ | | | | |
| △ | | | | | △ | | | | |
| △ | | | | | △ | | | | |

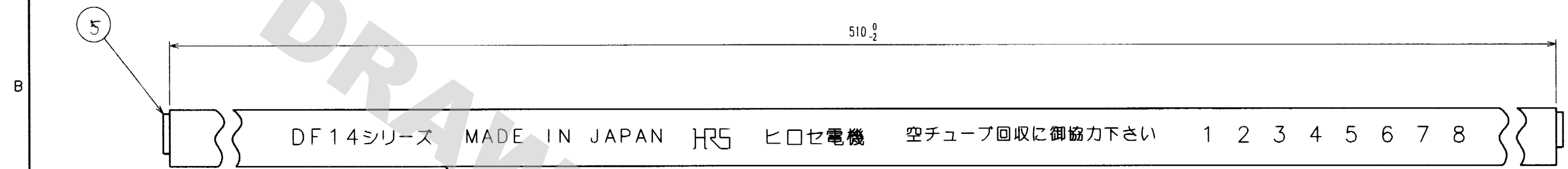

A →
A →

A-A (10:1)

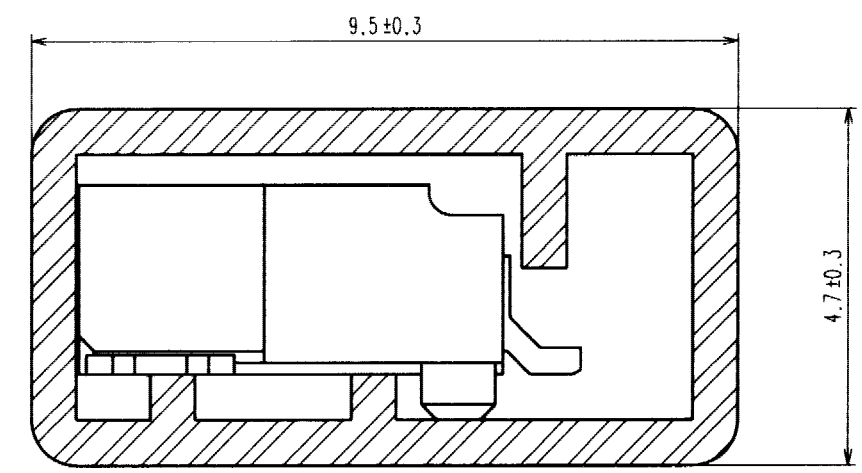

| PART NO. | CONTACTS | QUANTITY OF CONNECTOR |
|--------------------|----------|-----------------------|
| DF14-2P-1.25H(55) | 2 | 66 |
| DF14-3P-1.25H(55) | 3 | 56 |
| DF14-4P-1.25H(55) | 4 | 49 |
| DF14-5P-1.25H(55) | 5 | 44 |
| DF14-6P-1.25H(55) | 6 | 39 |
| DF14-7P-1.25H(55) | 7 | 36 |
| DF14-8P-1.25H(55) | 8 | 32 |
| DF14-9P-1.25H(55) | 9 | 30 |
| DF14-10P-1.25H(55) | 10 | 28 |
| DF14-15P-1.25H(55) | 15 | 20 |
| DF14-20P-1.25H(55) | 20 | 16 |
| DF14-25P-1.25H(55) | 25 | 13 |
| DF14-30P-1.25H(55) | 30 | 11 |

NOTE 4 THE TUBE HAS ONE STOPPER AT EACH END.
 5 WARPAGE OF THE TUBE SHALL BE ALLOWED ± 2mm PER 510mm.
 6 MINIMUM UNIT OF PURCHASE SHALL BE THE QUANTITY OF CONNECTORS IN TUBE.

| NO. | MATERIAL | FINISH, REMARKS | NO. | MATERIAL | FINISH, REMARKS |
|-------------------------------|----------|-----------------|-------------------------------|--------------------|--------------------|
| CODE NO. (OLD) CL | | | DRAWN | DESIGNED | CHECKED |
| | | | <i>F. Mitsuaki</i> | <i>S. Danpouya</i> | <i>T. Miyazaki</i> |
| | | | 03.3.5 | 03.3.7 | 03.03.10 |
| | | | | | APPROVED |
| | | | | | <i>T. Miyazaki</i> |
| | | | | | RELEASED |
| | | | | | |
| DRAWING NO. EDC3-160307-20 | | | PART NO. DF14-*P-1.25H(55) | | |
| SCALE FREE | | | CODE NO. CL538- | | |
| UNITS mm | | | 2 | | |

HRS HIROSE ELECTRIC CO., LTD

DRAWING FOR REFERENCE: This is subject to change without notice
08/11/2012

| |
|----|
| TO |
| |
| |
| |

Ⓝ