

SINGLE 2-INPUT AND GATE

- HIGH SPEED: $t_{PD} = 4.7 \text{ ns}$ (TYP.) at $V_{CC} = 5V$
- LOW POWER DISSIPATION:
 $I_{CC} = 1 \mu\text{A}$ (MAX.) at $T_A = 25^\circ\text{C}$
- COMPATIBLE WITH TTL OUTPUTS:
 $V_{IH} = 2V$ (MIN), $V_{IL} = 0.8V$ (MAX)
- POWER DOWN PROTECTION ON INPUTS & OUTPUT
- SYMMETRICAL OUTPUT IMPEDANCE:
 $|I_{OH}| = I_{OL} = 8 \text{ mA}$ (MIN)
- BALANCED PROPAGATION DELAYS:
 $t_{PLH} \cong t_{PHL}$
- OPERATING VOLTAGE RANGE:
 V_{CC} (OPR) = 4.5V to 5.5V
- IMPROVED LATCH-UP IMMUNITY

DESCRIPTION

The 74V1T08 is an advanced high-speed CMOS SINGLE 2-INPUT AND GATE fabricated with sub-micron silicon gate and double-layer metal wiring C²MOS technology. It has similar high speed performance of equivalent Bipolar Schottky TTL combined with true CMOS low power dissipation.

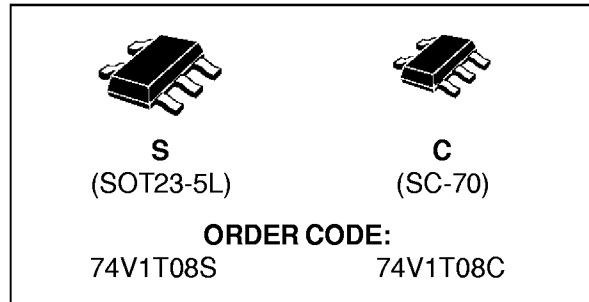

The internal circuit is composed of 2 stages including buffer output, which provide high noise immunity and stable output.

Power down protection is provided on all inputs and 0 to 7V can be accepted on inputs with no regard to the supply voltage. This device can be used to interface 5V to 3V.

PIN CONNECTION AND IEC LOGIC SYMBOLS

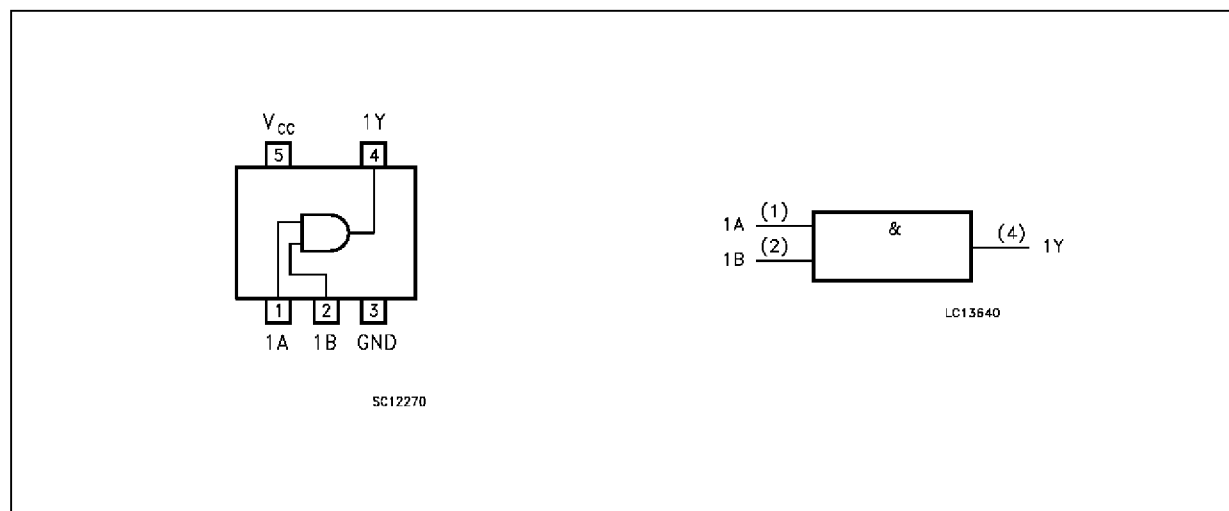

INPUT EQUIVALENT CIRCUIT

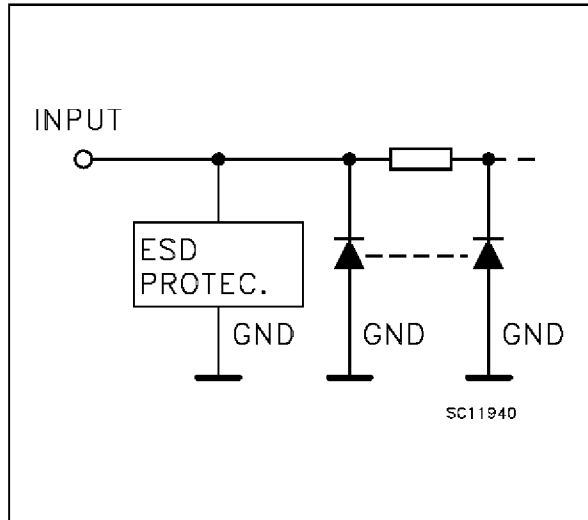

PIN DESCRIPTION

PIN No	SYMBOL	NAME AND FUNCTION
1	1A	Data Input
2	1B	Data Input
4	1Y	Data Output
3	GND	Ground (0V)
5	V _{CC}	Positive Supply Voltage

TRUTH TABLE

A	B	Y
L	L	L
L	H	L
H	L	L
H	H	H

ABSOLUTE MAXIMUM RATINGS

Symbol	Parameter	Value	Unit
V _{CC}	Supply Voltage	-0.5 to +7.0	V
V _I	DC Input Voltage	-0.5 to +7.0	V
V _O	DC Output Voltage (see note 1)	-0.5 to +7.0	V
V _O	DC Output Voltage (see note 2)	-0.5 to V _{CC} + 0.5	V
I _{IK}	DC Input Diode Current	- 20	mA
I _{OK}	DC Output Diode Current	± 20	mA
I _O	DC Output Current	± 25	mA
I _{CC} or I _{GND}	DC V _{CC} or Ground Current	± 50	mA
T _{stg}	Storage Temperature	-65 to +150	°C
T _L	Lead Temperature (10 sec)	260	°C

Absolute Maximum Ratings are those values beyond which damage to the device may occur. Functional operation under these condition is not implied.

1) V_{CC}=0V

2) High or Low State

RECOMMENDED OPERATING CONDITIONS

Symbol	Parameter	Value	Unit
V _{CC}	Supply Voltage	4.5 to 5.5	V
V _I	Input Voltage	0 to 5.5	V
V _O	Output Voltage (see note 1)	0 to 5.5	V
V _O	Output Voltage (see note 2)	0 to V _{CC}	V
T _{op}	Operating Temperature	-40 to +85	°C
dt/dv	Input Rise and Fall Time (see note 3) (V _{CC} = 5.0 ± 0.5V)	0 to 20	ns/V

1) V_{CC}=0V

2) High or Low State

3) V_{IN} from 0.8V to 2V

DC SPECIFICATIONS

Symbol	Parameter	Test Conditions		Value					Unit	
				V _{CC} (V)	T _A = 25 °C			-40 to 85 °C		
					Min.	Typ.	Max.	Min.		Max.
V _{IH}	High Level Input Voltage	4.5 to 5.5		2			2		V	
V _{IL}	Low Level Input Voltage	4.5 to 5.5				0.8		0.8	V	
V _{OH}	High Level Output Voltage	4.5	V _I = V _{IH}	IO=-50 μA	4.4	4.5		4.4		V
		4.5		IO=-8 mA	3.94			3.8		
V _{OL}	Low Level Output Voltage	4.5	V _I = V _{IH} or V _{IL}	IO=50 μA		0.0		0.1		V
		4.5		IO=8 mA				0.36	0.44	
I _I	Input Leakage Current	0 to 5.5	V _I = 5.5V or GND				±0.1		±1.0	μA
I _{CC}	Quiescent Supply Current	5.5	V _I = V _{CC} or GND				1		10	μA
ΔI _{CC}	Additional Worst Case Supply Current	5.5	One Input at 3.4V, other input at V _{CC} or GND				1.35		1.5	mA
I _{OPD}	Output Leakage Current	0	V _{OUT} = 5.5V		0		0.5		5.0	μA

AC ELECTRICAL CHARACTERISTICS (Input t_r = t_f = 3 ns)

Symbol	Parameter	Test Condition		Value					Unit	
				V _{CC} (*) (V)	T _A = 25 °C			-40 to 85 °C		
					Min.	Typ.	Max.	Min.		Max.
t _{PLH}	Propagation Delay Time	5.0	C _L = 15 pF			4.7	6.7	1.0	7.5	ns
t _{PHL}		5.0	C _L = 50 pF			5.5	7.7	1.0	8.5	

(*) Voltage range is 5V ± 0.5V

CAPACITIVE CHARACTERISTICS

Symbol	Parameter	Test Conditions		Value					Unit
				T _A = 25 °C			-40 to 85 °C		
				Min.	Typ.	Max.	Min.	Max.	
C _{IN}	Input Capacitance			4	10			10	pF
C _{PD}	Power Dissipation Capacitance (note 1)			14					pF

1) C_{PD} is defined as the value of the IC's internal equivalent capacitance which is calculated from the operating current consumption without load. (Refer to Test Circuit). Average operating current can be obtained by the following equation. I_{CC(OPR)} = C_{PD} • V_{CC} • f_{IN} + I_{CC}

74V1T08

TEST CIRCUIT

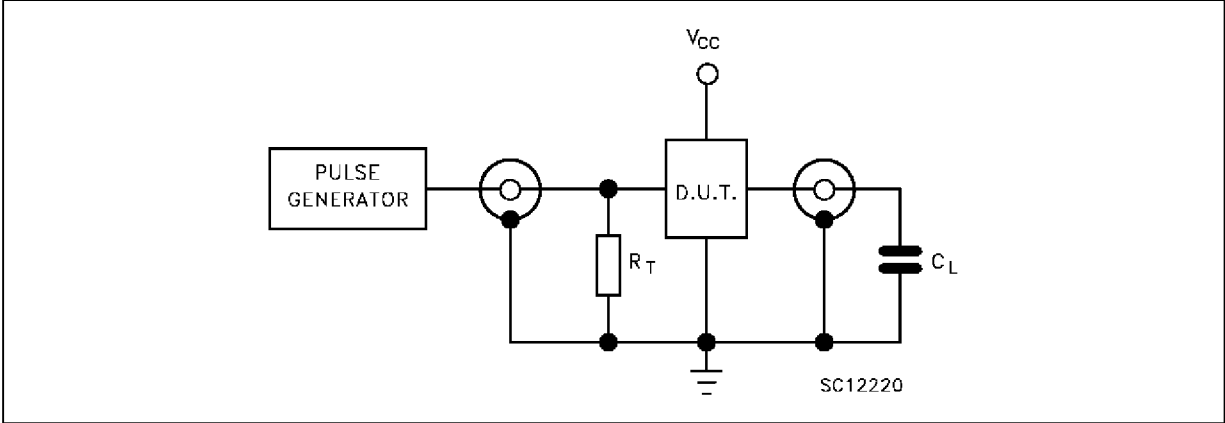

CL = 15/50 pF or equivalent (includes jig and probe capacitance)
RT = ZOUT of pulse generator (typically 50Ω)

WAVEFORM: PROPAGATION DELAYS (f=1MHz; 50% duty cycle)

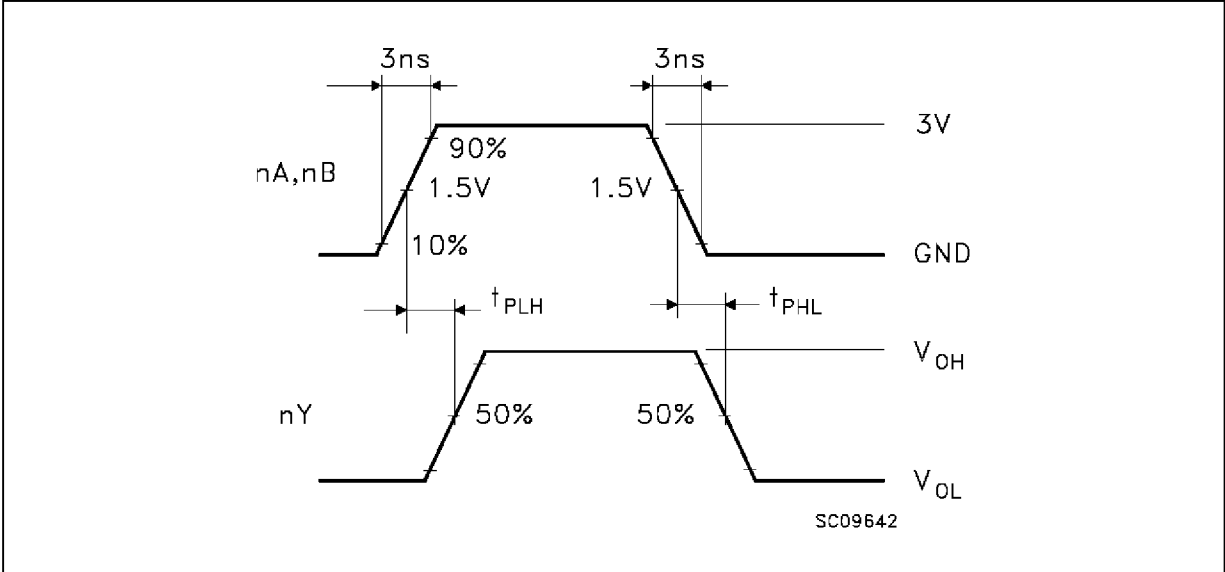

SOT23-5L MECHANICAL DATA

DIM.	mm			mils		
	MIN.	TYP.	MAX.	MIN.	TYP.	MAX.
A	0.90		1.45	35.4		57.1
A1	0.00		0.15	0.0		5.9
A2	0.90		1.30	35.4		51.2
b	0.35		0.50	13.7		19.7
C	0.09		0.20	3.5		7.8
D	2.80		3.00	110.2		118.1
E	2.60		3.00	102.3		118.1
E1	1.50		1.75	59.0		68.8
L	0.35		0.55	13.7		21.6
e		0.95			37.4	
e1		1.9			74.8	

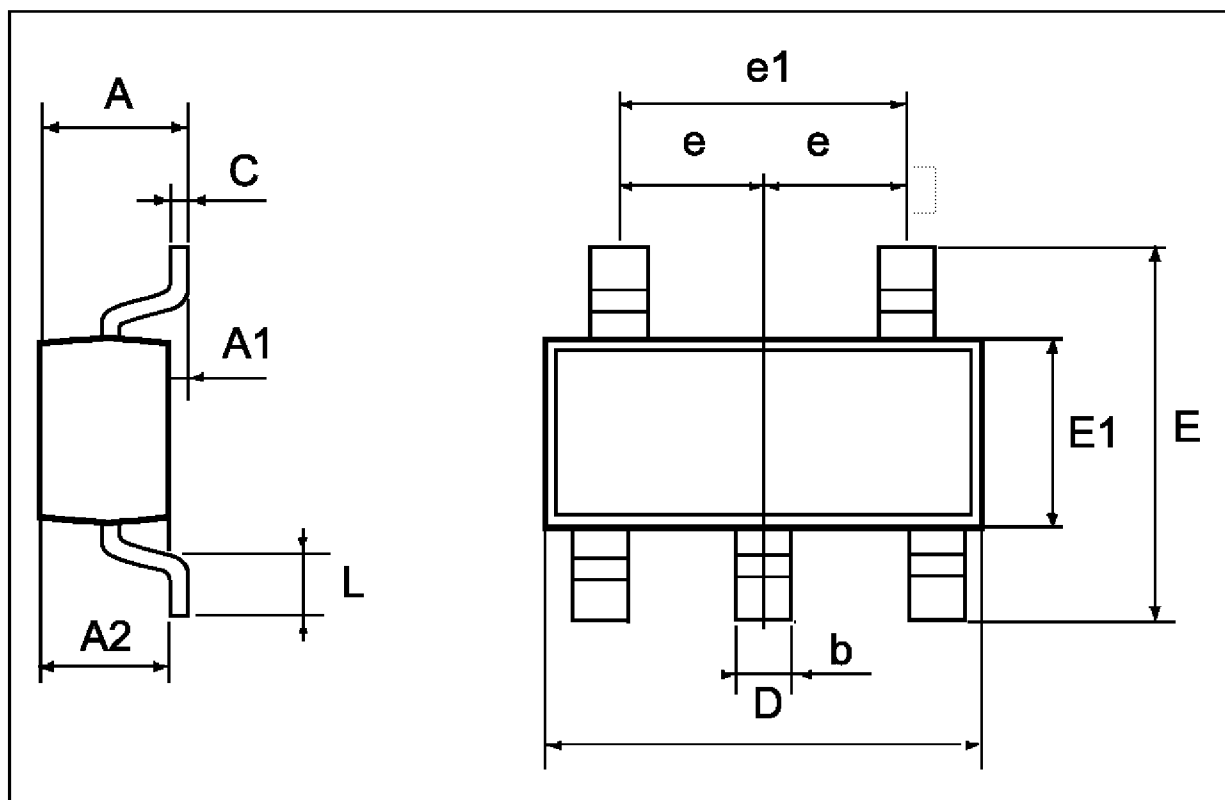

SC-70 MECHANICAL DATA

DIM.	mm			mils		
	MIN.	TYP.	MAX.	MIN.	TYP.	MAX.
A	0.80		1.10	31.5		43.3
A1	0.00		0.10	0.0		3.9
A2	0.80		1.00	31.5		39.4
b	0.15		0.30	5.9		11.8
C	0.10		0.18	3.9		7.1
D	1.80		2.20	70.9		86.6
E	1.80		2.40	70.9		94.5
E1	1.15		1.35	45.3		53.1
L	0.10		0.30	3.9		11.8
e		0.65			25.6	
e1		1.3			51.2	

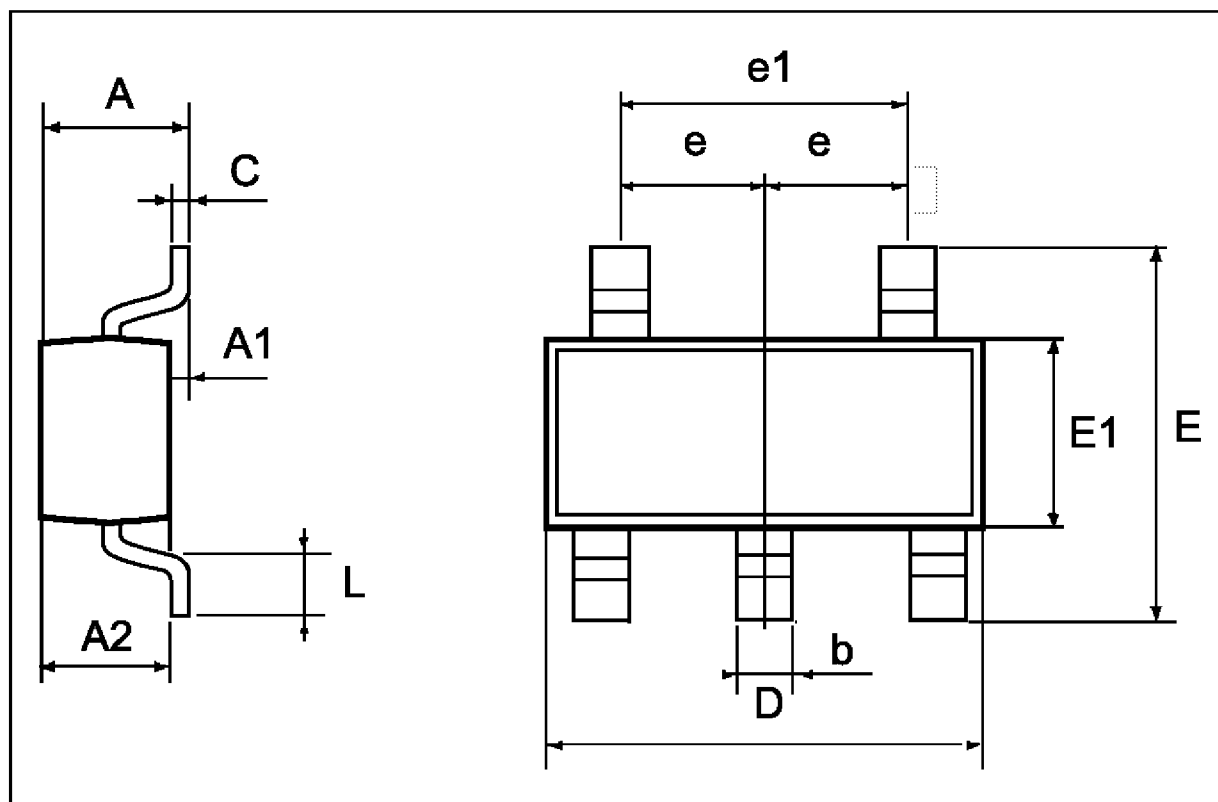

Information furnished is believed to be accurate and reliable. However, STMicroelectronics assumes no responsibility for the consequences of use of such information nor for any infringement of patents or other rights of third parties which may result from its use. No license is granted by implication or otherwise under any patent or patent rights of STMicroelectronics. Specification mentioned in this publication are subject to change without notice. This publication supersedes and replaces all information previously supplied. STMicroelectronics products are not authorized for use as critical components in life support devices or systems without express written approval of STMicroelectronics.

The ST logo is a trademark of STMicroelectronics

© 1999 STMicroelectronics – Printed in Italy – All Rights Reserved

STMicroelectronics GROUP OF COMPANIES

Australia - Brazil - Canada - China - France - Germany - Italy - Japan - Korea - Malaysia - Malta - Mexico - Morocco - The Netherlands -
Singapore - Spain - Sweden - Switzerland - Taiwan - Thailand - United Kingdom - U.S.A.

<http://www.st.com>