

■ **Features**

- State-of-the-art architecture
 - Non-volatile data storage
 - Supply voltage range: 2.7V ~ 5.5V
- 2 wire I²C serial interface
 - Providing bi-directional data transfer protocol
- Hard-ware write protection
 - With WP PIN to disable programming command
- 8 bytes page write mode
 - Minimizing total write time per word
- Self-timed write cycle (including auto-erase)
- Durability and reliability
 - 40 years data retention
 - Minimum of 1KK write/erase cycles per word
 - Unlimited read cycles
 - ESD protection
- Low standby current
- Package: PDIP, SOP and TSSOP

■ **General Description**

The AM24LC02 is a non-volatile, 2048-bit serial EEPROM with enhanced security device and conforms to all specifications in I²C 2-wire protocol. The whole memory can be disabled (Write Protected) by connecting the WP pin to Vcc. This section of memory then becomes unalterable unless WP is switched to Vss. The AM24LC02's communication protocol uses CLOCK(SCL) and DATA I/O(SDA) lines to synchronously clock data between the master (for example a microcomputer) and the slave EEPROM device(s). In addition, the bus structure allows for a maximum of 16K of EEPROM memory. This is supported by the family in 2K, 4K, 8K, 16K devices, allowing the user to configure the memory as the application requires with any combination of EEPROMs (not to exceed 16K). Anachip EEPROMs are designed and tested for application requiring high endurance, high reliability, and low power consumption.

■ **Connection Diagram**

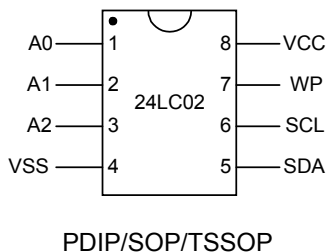

■ **Pin Assignments**

Name	Description
A0, A1, A2	Address Inputs
VSS	Ground
SDA	Data I/O
SCL	Clock Input
WP	Write Protect
VCC	Power Input

■ **Ordering Information**

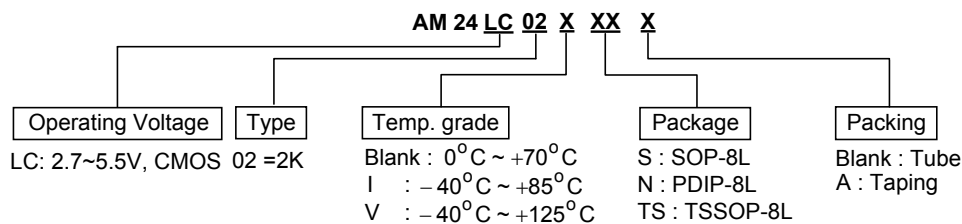

■ **Block Diagrams**

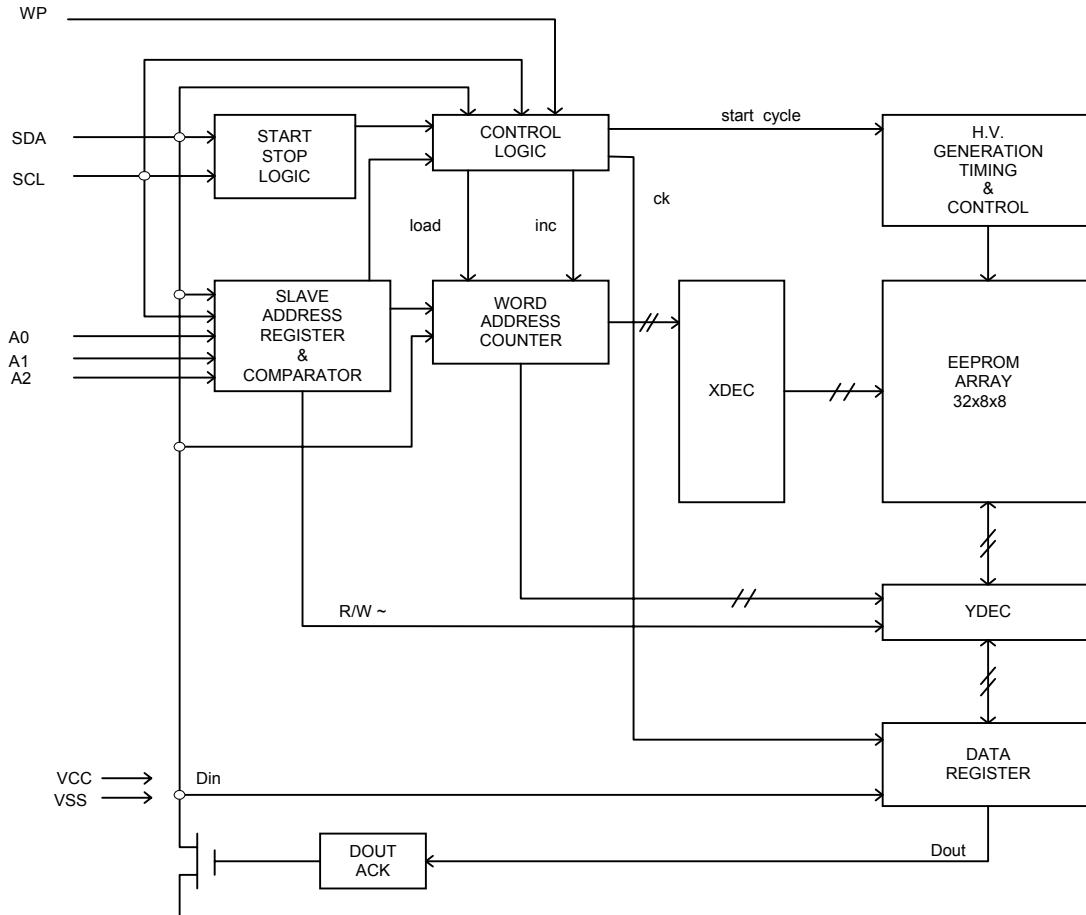

■ **Absolute Maximum Ratings**

Characteristics	Symbol	Values	Unit
Storage Temperature	T_s	-65 to + 125	°C
Voltage with Respect to Ground		-0.3 to + 6.5	V

NOTE: These are STRESS rating only. Appropriate conditions for operating these devices given elsewhere may permanently damage the part. Prolonged exposure to maximum ratings may affect device reliability.

■ **Operating Conditions**

Temperature under bias		Values	Unit
AM24LC02	Commercial	0 to + 70	°C
AM24LC02I	Industrial	-40 to +85	°C
AM24LC02V	Automotive	-40 to +125	°C

■ Electrical Characteristics

DC Electrical Characteristics (V_{CC} = 2.7~5.5V, T_a = 25°C)

Parameter	Symbol	Conditions	AM24LC02		Units
			Min	Max	
Operating Current (Program) **	I _{CC1}	SCL = 100KHz CMOS Input	—	3	mA
Operating Current (Read) **	I _{CC2}	SCL = 100KHz CMOS Input	—	200	μA
Standby Current	I _{SB1}	SCL=SDA=0V, V _{CC} =5V	—	10	μA
Standby Current	I _{SB2}	SCL=SDA=0V, V _{CC} =3V	—	1	
Input Leakage	I _{IL}	V _{IN} = 0 V to V _{CC}	-1	+1	μA
Output Leakage	I _{OL}	V _{OUT} = 0 V to V _{CC}	-1	+1	μA
Input Low Voltage**	V _{IL}		-0.1	V _{CC} x 0.3	V
Input High Voltage**	V _{IH}		V _{CC} x 0.7	V _{CC} + 0.2	V
Output Low Voltage	V _{OL1}	I _{OL} = 2.1mA TTL	—	0.4	V
Output Low Voltage	V _{OL2}	I _{OL} = 10uA CMOS	—	0.2	V
VCC Lockout Voltage	V _{LK}	Programming Command Can Be Executed	Default	—	V

Note ** : I_{CC1}, I_{CC2}, V_{IL} min and V_{IH} max are for reference only and are not tested.

■ Switching Characteristics (Under Operating Conditions)

AC Electrical Characteristics (V_{CC} = 2.7~5.5V)

Parameter	Symbol	AM24LC02		Units
		Min	Max	
Clock frequency	F _{scl}	0	100	kHz
Clock high time	T _{high}	4000	—	ns
Clock low time	T _{low}	4700	—	ns
SDA and SCL rise time**	T _r	—	1000	ns
SDA and SCL fall time**	T _f	—	300	ns
START condition hold time	T _{hd:Sta}	4000	—	ns
START condition setup time	T _{su:Sta}	4700	—	ns
Data input hold time	T _{hd:Dat}	0	—	ns
Data input setup time	T _{su:Dat}	250	—	ns
STOP condition setup time	T _{su:Sto}	4000	—	ns
Output valid from clock	T _{aa}	300	3500	ns
Bus free time **	T _{buf}	4700	—	ns
Data out hold time	T _{dh}	300	—	ns
Write cycle time	T _{wr}	—	10	ms
5V, 25°C, Byte Mode	Endurance**	1M	—	write cycles

Note ** :This parameter is characterized and is not 100% tested.

Capacitance TA= 25°C , f=250KHz

Symbol	Parameter	Max	Units
C _{OUT}	Output capacitance	5	pF
C _{IN}	Input capacitance	5	pF

A.C. Conditions of Test

Input Pulse Levels	V _{CC} x 0.1 to V _{CC} x 0.9
Input Rise and Fall times	10 ns
Input and Output Timing level	V _{CC} x 0.5
Output Load	1 TTL Gate and CL = 100pF



■ Pin Descriptions

Serial Clcok (SCL)

The SCL input is used to clock all data into and out of the device.

SerialL Data (SDA)

SDA is a bidirection pin used to transfer data or security bit into and out of the device. It is an open drain output and may be wire-ORed with any number of open drain or open collector outputs. Thus, the SDA bus requires a pull-up resistor to Vcc (typical 4.7KΩ for 100KHz, 1KΩ for 400KHz).

Device Address Inputs (A0, A1, A2)

The following table (Table A) shows the active pins across the AM24LCXX device family.

TABLE A

Device	A0	A1	A2
AM24LC02	ADR	ADR	ADR
AM24LC04	XP	ADR	ADR
AM24LC08	XP	XP	ADR
AM24LC16	XP	XP	XP

ADR indicates the device address pin.

XP indicates that device address pin does not care but refers to an internal PAGE BLOCK memory segment.

Write Protection (WP)

If WP is connected to Vcc, PROGRAM operation onto the whole memory will not be executed. READ operations are possible. If WP is connected to Vss, normal memory operation is enabled, READ/WRITE over the entire memory is possible.

■ Functional Description

Applications

ATC's electrically erasable programmable read only memories (EEPROMs) offer valuable security features including write protect function, two write modes, three read modes, and a wide variety of memory size. Typical applications for the I²C bus and AM24LCXX memories include SANs(small-area-networks), stereos, televisions, automobiles and other scaled-down systems that do not require tremendous speeds but instead cost efficiency and design simplicity.

Endurance And Data Retention

The AM24LC02 is designed for applications requiring up to 1KK programming cycles (BYTE WRITE and PAGE WRITE). It provides 40 years of secure data retention without power.

Device Operation

The AM24LC02 device supports a bidirectional bus oriented protocol. The protocol defines any device that sends data onto the bus as a transmitter and the receiving device as the receiver. The device controlling the transfer is the master and the device being controlled is the slave. The master will always initiate data transfers and provide the clock for both transmit and receive operations. Therefore, the AM24LC02 is considered a slave in all applications.

Clock and Data Conventions

Data states on the SDA line can be changed only during SCL LOW. SDA state changes during SCL HIGH are reserved for indicating start and stop conditions. (Shown in Figures 1 and 2)

Start Condition

A HIGH to LOW transition of the SDA line while the clock (SCL) is HIGH determines a START condition. All commands must be preceded with a START condition. (Shown in Figure 2)

Stop Condition

A LOW to HIGH transition of the SDA line while the clock (SCL) is HIGH determines a STOP condition. All operations must be ended with a STOP condition. (Shown in Figure 2)

■ Functional Description (Continued)

Acknowledge

Each receiving device, when addressed, is obliged to generate an acknowledge after the reception of each byte. The master device must generate an extra clock pulse which is associated with this acknowledge bit. The device that acknowledges, has to pull down the SDA line during the acknowledge clock pulse in such a way that the SDA line is stable LOW during the HIGH period of the acknowledge related clock pulse. Of course, setup and hold times must be taken into account. A master must signal an end of data to the slave by not generating an acknowledge bit on the last byte that has been clocked out of the slave. In this case, the slave must leave the data line HIGH to enable the master to generate the STOP condition. (Shown in Figure 3)

Devices Addressing

After generating a START condition, the bus master transmits the slave address consisting of a 4-bit device code (1010) for the AM24LC02, 3-bit device address (A2 A1 A0) and 1-bit value indicating the

read or write mode. All I²C EEPROMs use an internal protocol that defines a PAGE BLOCK size of 16K bits. The AM24LC02 contains one 2K-bits PAGE BLOCK, and the device address bits A0, A1 and A2 are used for determining which device will be proceeded in. The eighth bit of slave address determines if the master device wants to read or write to the AM24LC02 (Refer to table B).

The AM24LC02 monitors the bus for its corresponding slave address all the time. It generates an acknowledge bit if the slave address was true and it is not in a programming mode.

Operation	Control Code	Chip Select	R/W
Read	1010	A2 A1	1
Write	1010	A0 A2 A1 A0	0

Table B
A0, A1, A2 is used to access the AM24LC02.

■ Write Operations

Byte Write

Following the start signal from the master, the slave address is placed onto the bus by the master transmitter. This indicates to the addressed slave receiver that a byte with a word address will follow after it has generated an acknowledge bit during the ninth clock cycle. Therefore the next byte transmitted by the master is the word address and will be written into the address pointer of the AM24LC02. After receiving another acknowledge signal from the AM24LC02 the master device will transmit the data word to be written into the addressed memory location. The AM24LC02 acknowledges again and the master generates a stop condition. This initiates the internal write cycle, and during this period the AM24LC02 will not generate acknowledge signals. (Shown in Figure 4)

Page Write

The write control byte, word address and the first data byte are transmitted to the AM24LC02 in the same way as in a byte write. But instead of generating a stop condition the master transmit up to 8 data bytes to the AM24LC02 which are

temporarily stored in the on-chip page buffer and will be written into the memory after the master has transmitted a stop condition. If the master transmits more than 8 bytes prior to generating the stop condition, the address counter will roll over and the previously received data will be overwritten. As with the byte write operation, once the stop condition is received an internal write cycle will begin. (Shown in Figure 5)

Acknowledge Polling

Since the device will not acknowledge during a write cycle, this can be used to determine when the cycle is complete (this feature can be used to maximize bus throughput). Once the stop condition for a write command has been issued from the master, the device initiates the internally timed write cycle. ACK polling can be initiated immediately. This involves the master sending a start condition followed by the control byte for a write command (R/W = 0). If the device is still busy with the write cycle, then no ACK will returned. If the cycle is complete then the device will return the ACK and the master can then proceed with the next read or write commands.

■ Write Operations (Continued)

Write Protection

Programming will not take place if the WP pin of the AM24LC02 is connected to Vcc. The AM24LC02 will accept slave and byte addresses; but if the memory accessed is write protected by the WP pin, the AM24LC02 will not generate an acknowledge after the first byte of data has been received, and thus the programming cycle will not be started when the stop condition is asserted.

Read Operations

Read operations are initiated in the same way as write operations with the exception that the R/W bit of the slave address is set to one. There are three basic types of read operations: current address read, random read, and sequential read.

Current Address Read

The AM24LC02 contains an address counter that maintains the address of the last accessed word, internally incremented by one. Therefore if the previous access (either a read or write operation) was to address n, the next current address read operation would access data from address n + 1. Upon receipt of the slave address with R/W bit set to one, the AM24LC02 issues an acknowledge and transmits the eight bit data word. The master will not acknowledge the transfer but does generate a stop condition and the AM24LC02 discontinues transmission. (Shown in Figure 6)

Random Read

Random read operations allow the master to access

any memory location in a random manner. To perform this type of read operation, first the word address must be set. This is done by sending the word address to the AM24LC02 as part of a write operation. After the word address is sent, the master generates a start condition following the acknowledge. This terminates the write operation, but not before the internal address pointer is set. Then the master issues the control byte again but with R/W bit set to a one. The AM24LC02 will then issue an acknowledge and transmit the eight bit data word. The master will not acknowledge the transfer but does generate a stop condition and the AM24LC02 discontinues transmission. (Shown in Figure 7)

Sequential Read

Sequential read is initiated in the same way as a random read except that after the AM24LC02 transmits the first data byte, the master issues an acknowledge as opposed to a stop condition in a random read. This directs the AM24LC02 to transmit the next sequentially addressed 8 bit word (Shown in Figure 8). To provide sequential read the AM24LC02 contains an internal address pointer which is incremented by one at the completion of each operation.

Noise Protection

The SCL and SDA inputs have filter circuits which suppress noise spikes to assure proper device operation even on a noisy bus and to avert data alteration.

■ Timing Diagram

Bus Timing

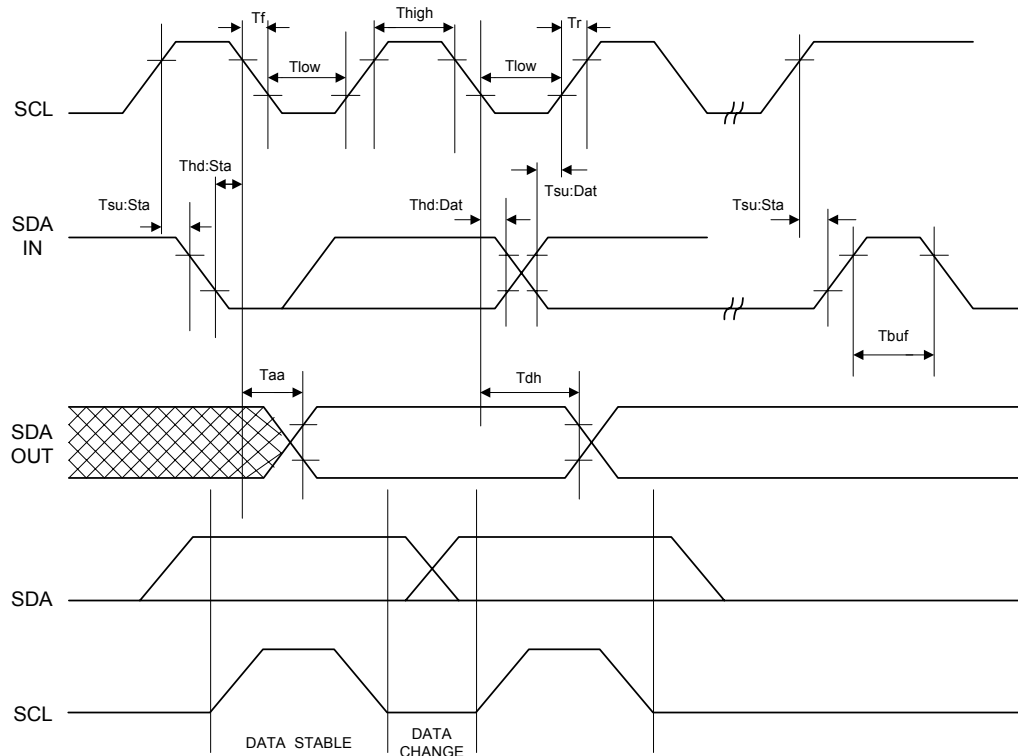

Figure 1. Data Validity

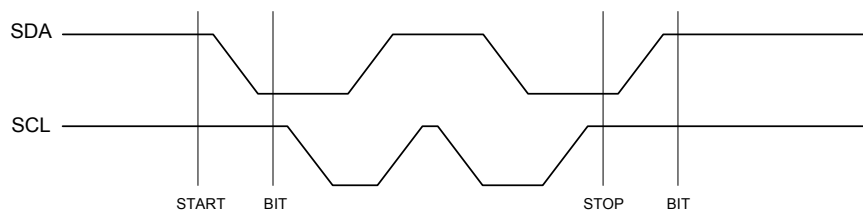

Figure 2. Definition of Start and Stop

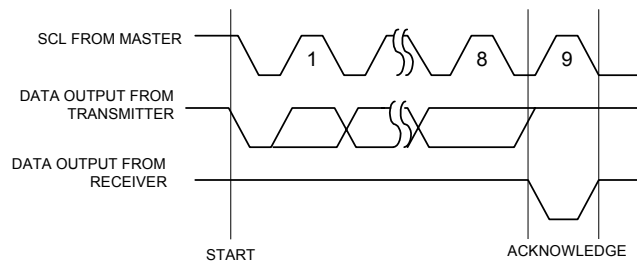

Figure 3. Acknowledge Response from Receiver

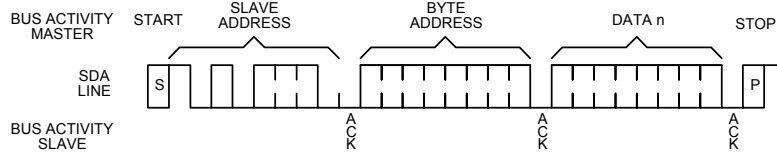

Figure 4. Byte Write for Data

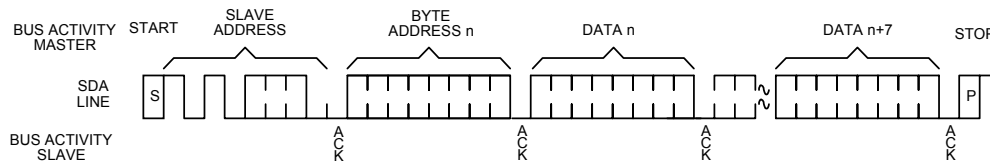

Figure 5. Page Write for Data

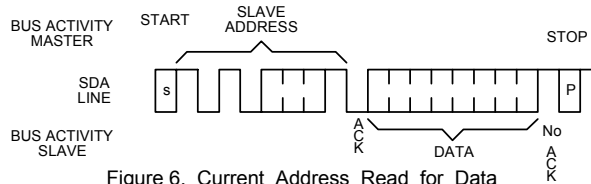

Figure 6. Current Address Read for Data

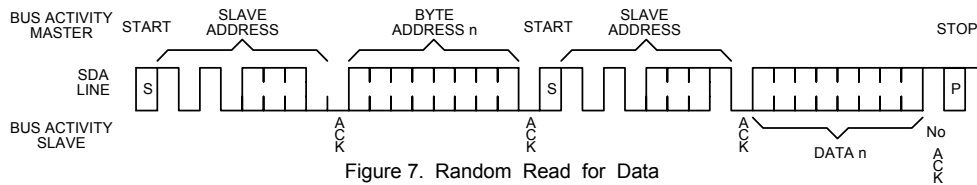

Figure 7. Random Read for Data

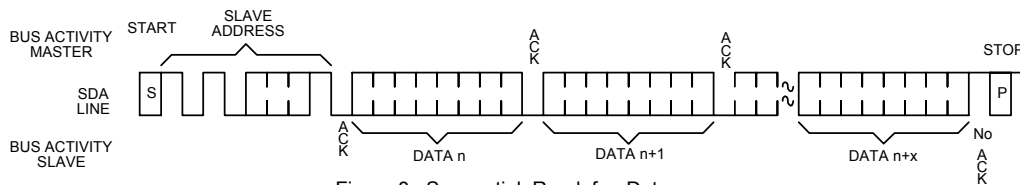
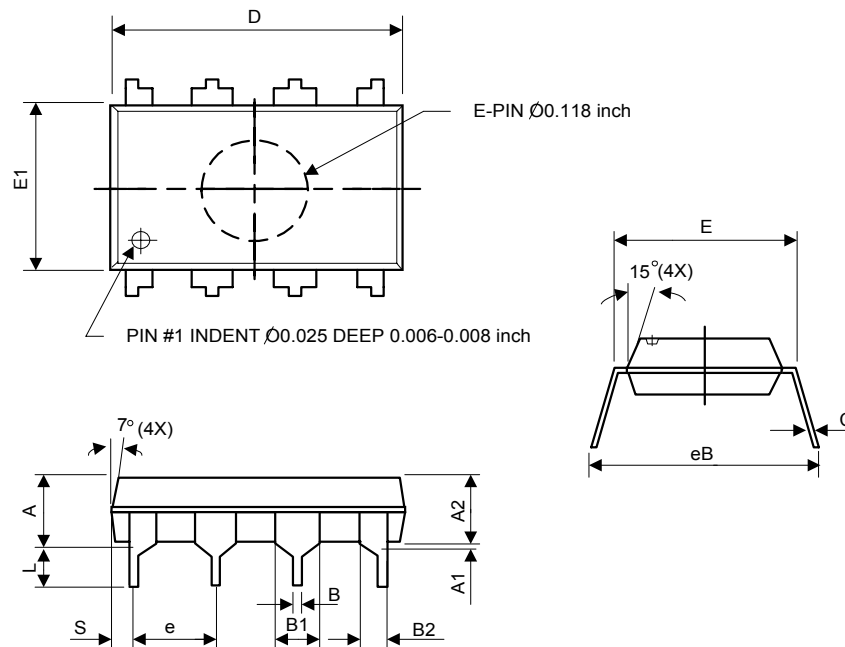

Figure 8. Sequential Read for Data

■ **Package Information**

(1)Package Type: PDIP-8L



Symbol	Dimensions in millimeters			Dimensions in inches		
	Min.	Nom.	Max.	Min.	Nom.	Max.
A	-	-	5.33	-	-	0.210
A1	0.38	-	-	0.015	-	-
A2	3.1	3.30	3.5	0.122	0.130	0.138
B	0.36	0.46	0.56	0.014	0.018	0.022
B1	1.4	1.52	1.65	0.055	0.060	0.065
B2	0.81	0.99	1.14	0.032	0.039	0.045
C	0.20	0.25	0.36	0.008	0.010	0.014
D	9.02	9.27	9.53	0.355	0.365	0.375
E	7.62	7.94	8.26	0.300	0.313	0.325
E1	6.15	6.35	6.55	0.242	0.250	0.258
e	-	2.54	-	-	0.100	-
L	2.92	3.3	3.81	0.115	0.130	0.150
eB	8.38	8.89	9.40	0.330	0.350	0.370
S	0.71	0.84	0.97	0.028	0.033	0.038

(2)Package Type: SOP-8L

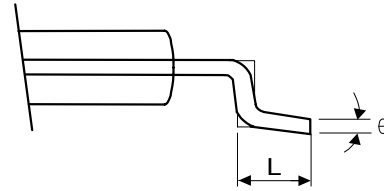
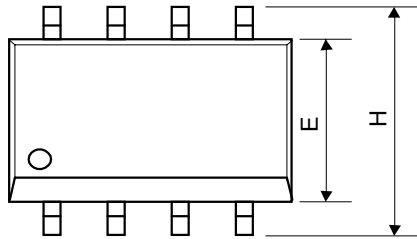

VIEW "A"

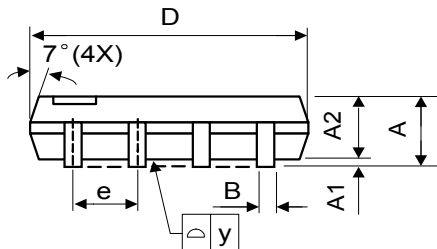

VIEW "A"

Symbol	Dimensions In Millimeters			Dimensions In Inches		
	Min.	Nom.	Max.	Min.	Nom.	Max.
A	1.40	1.60	1.75	0.055	0.063	0.069
A1	0.10	-	0.25	0.040	-	0.100
A2	1.30	1.45	1.50	0.051	0.057	0.059
B	0.33	0.41	0.51	0.013	0.016	0.020
C	0.19	0.20	0.25	0.0075	0.008	0.010
D	4.80	5.05	5.30	0.189	0.199	0.209
E	3.70	3.90	4.10	0.146	0.154	0.161
e	-	1.27	-	-	0.050	-
H	5.79	5.99	6.20	0.228	0.236	0.244
L	0.38	0.71	1.27	0.015	0.028	0.050
y	-	-	0.10	-	-	0.004
θ	0°	-	8°	0°	-	8°

(3)Package Type: TSSOP-8L

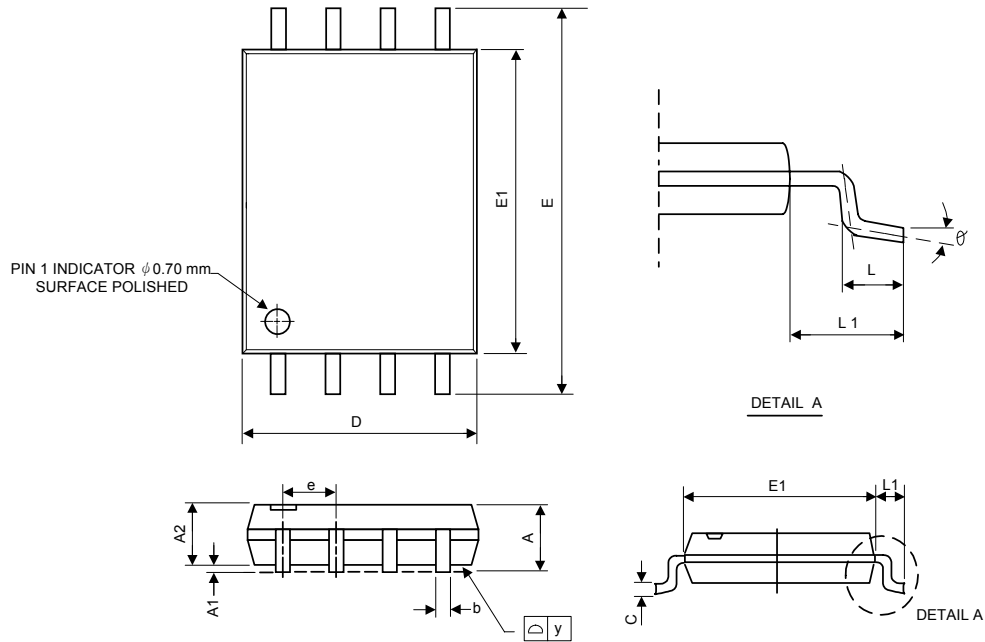

Symbol	Dimensions In Millimeters			Dimensions In Inches		
	Min.	Nom.	Max.	Min.	Nom.	Max.
A	1.05	1.10	1.20	0.041	0.043	0.047
A1	0.05	0.10	0.15	0.002	0.004	0.006
A2	-	1.00	1.05	-	0.039	0.041
b	0.20	0.25	0.28	0.008	0.01	0.011
C	-	0.13	-	-	0.005	-
D	2.90	3.05	3.10	0.114	0.12	0.122
E	6.20	6.40	6.60	0.244	0.252	0.26
E1	4.30	4.40	4.50	0.169	0.173	0.177
e	-	0.65	-	-	0.026	-
L	0.50	0.60	0.70	0.02	0.024	0.028
L1	0.90	1.00	1.10	0.035	0.039	0.043
y	-	-	0.10	-	-	0.004
θ	0°	4°	8°	0°	4°	8°

■ **Marking Information**

(1) PDIP-8L & SOP-8L

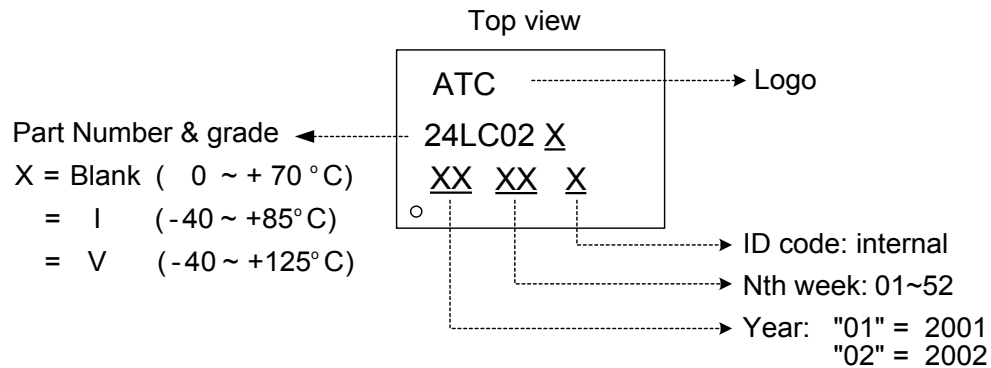

(2) TSSOP-8L

