

SN74ALS638A, SN74ALS639A, SN74AS638A, SN74AS639 OCTAL BUS TRANSCEIVERS

SDAS123A – DECEMBER 1983 – REVISED JANUARY 1995

- Bidirectional Bus Transceivers in High-Density 20-Pin Packages
- Choice of True or Inverting Logic
- A-Bus Outputs Are Open Collector; B-Bus Outputs Are 3 State
- Package Options Include Plastic Small-Outline (DW) Packages and Standard Plastic (N) 300-mil DIPs

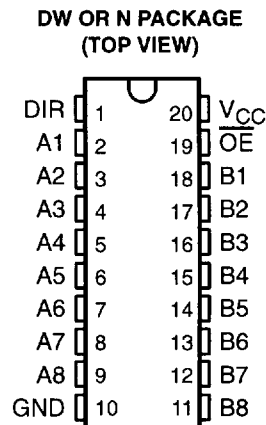

DEVICE	A OUTPUT	B OUTPUT	LOGIC
SN74ALS638A, SN74AS638A	Open collector	3 state	Inverting
SN74ALS639A, SN74AS639	Open collector	3 state	True

description

These octal bus transceivers are designed for asynchronous two-way communication between open-collector and 3-state buses. The devices transmit data from the A bus (open-collector) to the B bus (3 state) or from the B bus to the A bus, depending on the logic level at the direction-control (DIR) input. The output-enable (\overline{OE}) input can be used to disable the device so the buses are isolated.

The -1 version of SN74ALS638A is identical to the standard version, except that the recommended maximum I_{OL} is increased to 48 mA.

The SN74ALS638A, SN74ALS639A, SN74AS638A, and SN74AS639 are characterized for operation from 0°C to 70°C.

FUNCTION TABLE

INPUTS		OPERATION	
\overline{OE}	DIR	SN74ALS638A SN74AS638A	SN74ALS639A SN74AS639
L	L	\overline{B} data to A bus	B data to A bus
L	H	\overline{A} data to B bus	A data to B bus
H	X	Isolation	Isolation

PRODUCTION DATA information is current as of publication date. Products conform to specifications per the terms of Texas Instruments standard warranty. Production processing does not necessarily include testing of all parameters.

 **TEXAS
INSTRUMENTS**

POST OFFICE BOX 655303 • DALLAS, TEXAS 75265

Copyright © 1995, Texas Instruments Incorporated

SN74ALS638A, SN74ALS639A, SN74AS638A, SN74AS639A OCTAL BUS TRANSCEIVERS

SDAS123A – DECEMBER 1983 – REVISED JANUARY 1995

logic symbols†

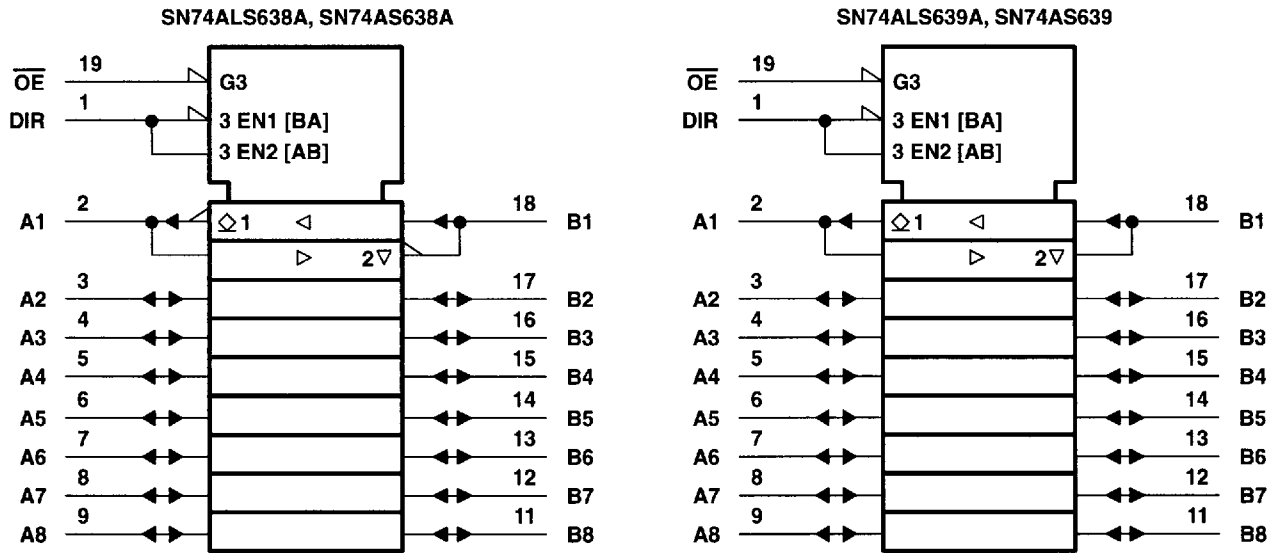

† These symbols are in accordance with ANSI/IEEE Std 91-1984 and IEC Publication 617-12.

logic diagrams (positive logic)

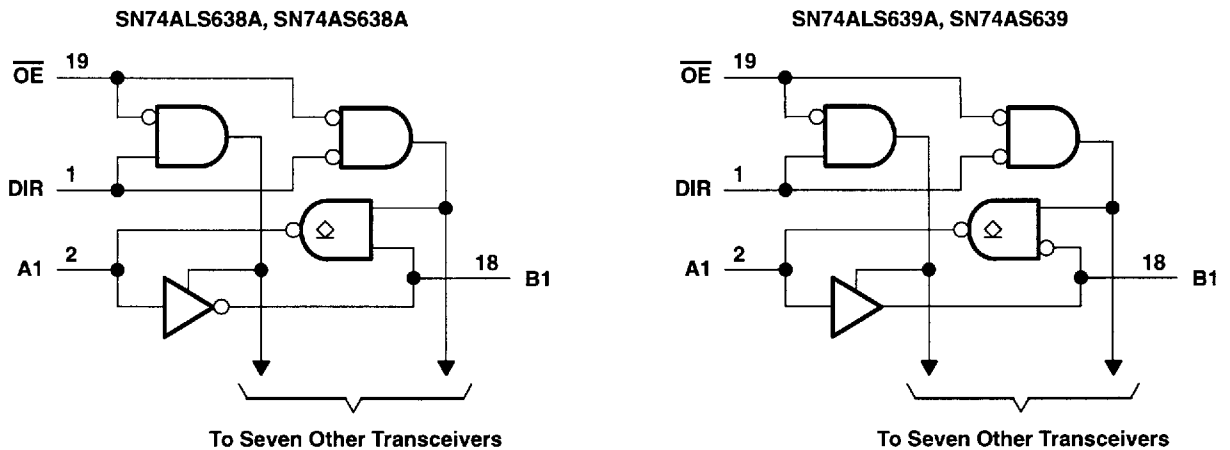

absolute maximum ratings over operating free-air temperature range (unless otherwise noted)‡

Supply voltage, V_{CC}	7 V
Input voltage, V_I : All inputs	7 V
A-bus I/O ports	7 V
B-bus I/O ports	5.5 V
Operating free-air temperature range, T_A : SN74ALS638A, SN74ALS639A	0°C to 70°C
Storage temperature range	-65°C to 150°C

‡ Stresses beyond those listed under "absolute maximum ratings" may cause permanent damage to the device. These are stress ratings only, and functional operation of the device at these or any other conditions beyond those indicated under "recommended operating conditions" is not implied. Exposure to absolute-maximum-rated conditions for extended periods may affect device reliability.

SN74ALS638A, SN74ALS639A, SN74AS638A, SN74AS639 OCTAL BUS TRANSCEIVERS

SDAS123A – DECEMBER 1983 – REVISED JANUARY 1995

recommended operating conditions

		SN74ALS638A SN74ALS639A			UNIT
		MIN	NOM	MAX	
V _{CC}	Supply voltage	4.5	5	5.5	V
V _{IH}	High-level input voltage	2			V
V _{IL}	Low-level input voltage			0.8	V
V _{OH}	High-level output voltage			5.5	V
I _{OH}	High-level output current			-15	mA
I _{OL}	Low-level output current		A or B ports	24	mA
				48†	
T _A	Operating free-air temperature	0		70	°C

† Applies only to the SN74ALS638A-1 version and only if V_{CC} is between 4.75 V and 5.25 V

electrical characteristics over recommended operating free-air temperature range (unless otherwise noted)

PARAMETER		TEST CONDITIONS		SN74ALS638A SN74ALS639A		UNIT	
				MIN	TYP‡		MAX
V _{IK}		V _{CC} = 4.5 V,	I _I = -18 mA		-1.5	V	
I _{OH}	A ports	V _{CC} = 4.5 V,	V _{OH} = 5.5 V		0.1	mA	
V _{OH}	B ports	V _{CC} = 4.5 V to 5.5 V,	I _{OH} = -0.4 mA	V _{CC} - 2		V	
		V _{CC} = 4.5 V	I _{OH} = -3 mA	2.4	3.2		
V _{OL}	A or B ports	V _{CC} = 4.5 V	I _{OH} = -15 mA	2		V	
			I _{OL} = 12 mA		0.25		0.4
			I _{OL} = 24 mA		0.35		0.5
I _I	Control inputs	V _{CC} = 5.5 V	V _I = 7 V		0.1	mA	
	A or B ports		V _I = 5.5 V		0.1		
I _{IH}	Control inputs	V _{CC} = 5.5 V,	V _I = 2.7 V		20	μA	
	A or B ports§				20		
I _{IL}	Control inputs	V _{CC} = 5.5 V,	V _I = 0.4 V		-0.1	mA	
	A or B ports§				-0.1		
I _O ¶	B ports	V _{CC} = 5.5 V,	V _O = 2.25 V	-30	-112	mA	
I _{CC}	SN74ALS638A	V _{CC} = 5.5 V	Outputs high	18	30	mA	
			Outputs low	26	41		
			Outputs disabled	16	30		
	SN74ALS639A	V _{CC} = 5.5 V	Outputs high	25	40		
			Outputs low	30	50		
			Outputs disabled	33	54		

† Applies only to the SN74ALS638A-1 version and only if V_{CC} is between 4.75 V and 5.25 V

‡ All typical values are at V_{CC} = 5 V, T_A = 25°C.

§ For I/O ports, the parameters I_{IH} and I_{IL} include the off-state output current.

¶ The output conditions have been chosen to produce a current that closely approximates one half of the true short-circuit output current, I_{OS}.



POST OFFICE BOX 655303 • DALLAS, TEXAS 75265

SN74ALS638A, SN74ALS639A, SN74AS638A, SN74AS639

OCTAL BUS TRANSCEIVERS

SDAS123A – DECEMBER 1983 – REVISED JANUARY 1995

switching characteristics (see Figure 1)

PARAMETER	FROM (INPUT)	TO (OUTPUT)	V _{CC} = 4.5 V to 5.5 V, C _L = 50 pF, R _L = 680 Ω (A outputs), R ₁ = R ₂ = 500 Ω (B outputs), T _A = MIN to MAX†				UNIT
			SN74ALS638A		SN74ALS639A		
			MIN	MAX	MIN	MAX	
t _{PLH}	A	B	2	12	2	12	ns
t _{PHL}			2	12	2	12	
t _{PLH}	B	A	8	25	10	30	ns
t _{PHL}			8	30	5	22	
t _{PLH}	\overline{OE}	A	5	25	10	30	ns
t _{PHL}			10	45	10	35	
t _{PZH}	\overline{OE}	B	5	20	6	21	ns
t _{PZL}			5	22	8	25	
t _{PHZ}	\overline{OE}	B	2	10	2	10	ns
t _{PLZ}			3	15	3	16	

† For conditions shown as MIN or MAX, use the appropriate value specified under recommended operating conditions.

absolute maximum ratings over operating free-air temperature range (unless otherwise noted)‡

Supply voltage, V _{CC}	7 V
Input voltage, V _i : All inputs	7 V
A-bus I/O ports	7 V
B-bus I/O ports	5.5 V
Operating free-air temperature range, T _A : SN74AS638A, SN74AS639	0°C to 70°C
Storage temperature range	-65°C to 150°C

‡ Stresses beyond those listed under "absolute maximum ratings" may cause permanent damage to the device. These are stress ratings only, and functional operation of the device at these or any other conditions beyond those indicated under "recommended operating conditions" is not implied. Exposure to absolute-maximum-rated conditions for extended periods may affect device reliability.

recommended operating conditions

		SN74AS638A SN74AS639			UNIT
		MIN	NOM	MAX	
V _{CC}	Supply voltage	4.5	5	5.5	V
V _{IH}	High-level input voltage	2			V
V _{IL}	Low-level input voltage			0.8	V
V _{OH}	High-level output voltage			5.5	V
I _{OH}	High-level output current			-15	mA
I _{OL}	Low-level output current			64	mA
T _A	Operating free-air temperature	0		70	°C



POST OFFICE BOX 655303 • DALLAS, TEXAS 75265

SN74ALS638A, SN74ALS639A, SN74AS638A, SN74AS639 OCTAL BUS TRANSCEIVERS

SDAS123A – DECEMBER 1983 – REVISED JANUARY 1995

electrical characteristics over recommended operating free-air temperature range (unless otherwise noted)

PARAMETER		TEST CONDITIONS		SN74AS638A SN74AS639			UNIT	
				MIN	TYP†	MAX		
V _{IK}		V _{CC} = 4.5 V, I _I = -18 mA		-1.2			V	
I _{OH}	A ports	V _{CC} = 4.5 V, V _{OH} = 5.5 V		0.1			mA	
V _{OH}	B ports	V _{CC} = 4.5 V to 5.5 V, I _{OH} = -2 mA		V _{CC} - 2			V	
		V _{CC} = 4.5 V, I _{OH} = -3 mA		2.4	3.2			
		V _{CC} = 4.5 V, I _{OH} = -15 mA		2.4				
V _{OL}		V _{CC} = 4.5 V, I _{OL} = 64 mA		0.35	0.55		V	
I _I	Control inputs	V _{CC} = 5.5 V, V _I = 7 V		0.1			mA	
	A or B ports	V _{CC} = 5.5 V, V _I = 5.5 V		0.1				
I _{IH}	Control inputs	V _{CC} = 5.5 V, V _I = 2.7 V		20			μA	
	A or B ports‡	V _{CC} = 5.5 V, V _I = 2.7 V		70				
I _{IL}	Control inputs	V _{CC} = 5.5 V, V _I = 0.4 V		-0.5			mA	
	A or B ports‡	V _{CC} = 5.5 V, V _I = 0.4 V		-0.75				
I _{OS} §		V _{CC} = 5.5 V, V _O = 2.25 V		-50	-150		mA	
I _{CC}	SN74AS638A	V _{CC} = 5.5 V		Outputs high		24	54	mA
		V _{CC} = 5.5 V		Outputs low		75	122	
		V _{CC} = 5.5 V		Outputs disabled		37	61	
	SN74AS639	V _{CC} = 5.5 V		Outputs high		56	92	
		V _{CC} = 5.5 V		Outputs low		95	154	
		V _{CC} = 5.5 V		Outputs disabled		62	100	

† All typical values are at V_{CC} = 5 V, T_A = 25°C.

‡ For I/O ports, the parameters I_{IH} and I_{IL} include the off-state output current.

§ The output conditions have been chosen to produce a current that closely approximates one half of the true short-circuit output current, I_{OS}.

switching characteristics (see Figure 1)

PARAMETER	FROM (INPUT)	TO (OUTPUT)	V _{CC} = 4.5 V to 5.5 V, C _L = 50 pF, R _L = 500 Ω (A outputs), R _L = 500 Ω (B outputs), T _A = MIN to MAX††				UNIT
			SN74AS638A		SN74AS639		
			MIN	MAX	MIN	MAX	
t _{PLH}	A	B	2	7	2	9.5	ns
t _{PHL}			2	6.5	2	9	
t _{PLH}	B	A	5	20	5	22	ns
t _{PHL}			2	7	2	9	
t _{PLH}	OE	A	5	19	5	21.5	ns
t _{PHL}			2	9	2	11.5	
t _{PZH}	OE	B	2	8	2	10.5	ns
t _{PZL}			2	10	2	10.5	
t _{PHZ}	OE	B	2	7	2	7	ns
t _{PLZ}			2	10	2	10.5	

†† For conditions shown as MIN or MAX, use the appropriate value specified under recommended operating conditions.



POST OFFICE BOX 655303 • DALLAS, TEXAS 75265

SN74ALS638A, SN74ALS639A, SN74AS638A, SN74AS639 OCTAL BUS TRANSCEIVERS

SDAS123A – DECEMBER 1983 – REVISED JANUARY 1995

PARAMETER MEASUREMENT INFORMATION SERIES 54ALS/74ALS AND 54AS/74AS DEVICES

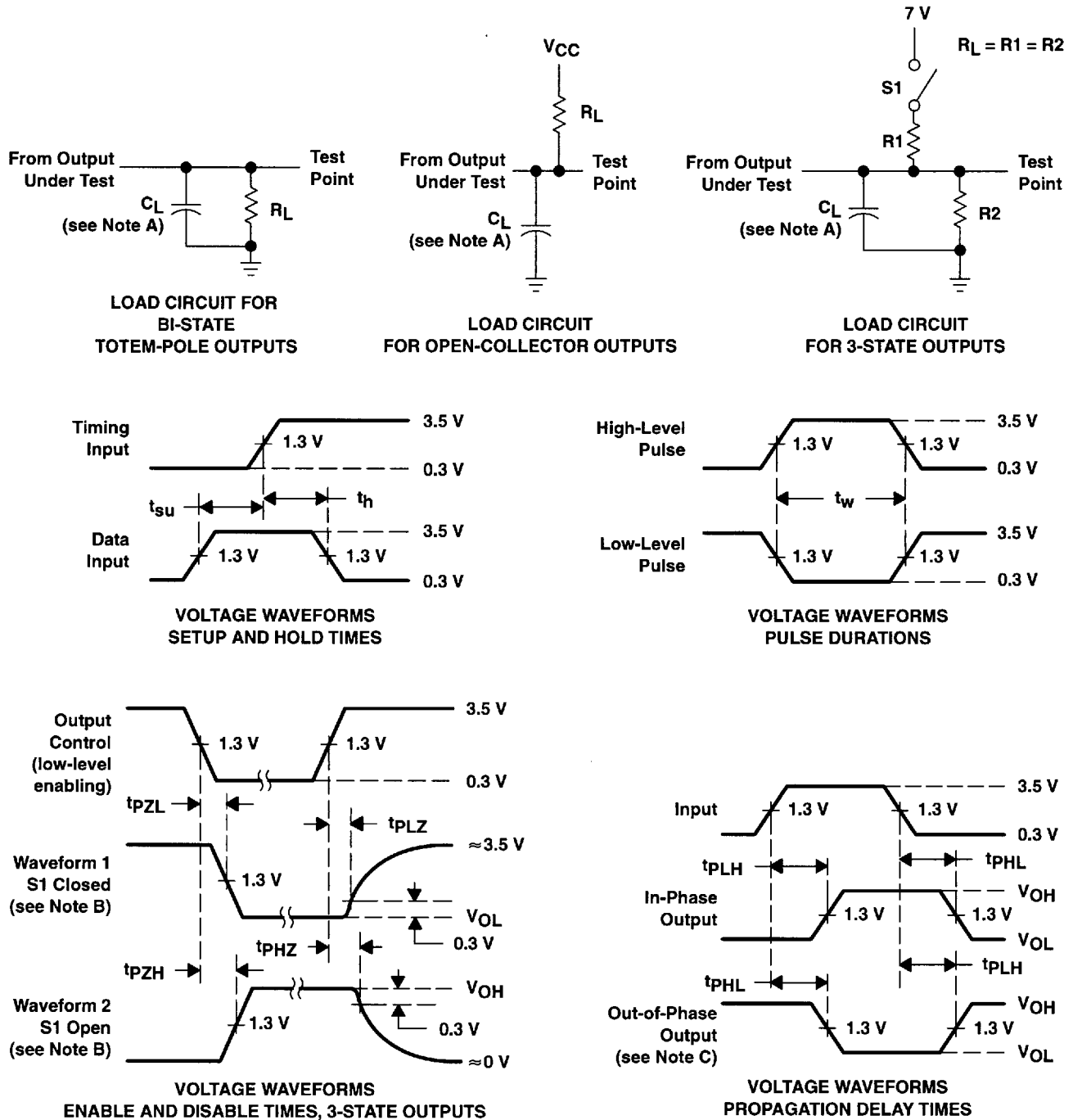

- NOTES: A. C_L includes probe and jig capacitance.
 B. Waveform 1 is for an output with internal conditions such that the output is low except when disabled by the output control. Waveform 2 is for an output with internal conditions such that the output is high except when disabled by the output control.
 C. When measuring propagation delay items of 3-state outputs, switch S1 is open.
 D. All input pulses have the following characteristics: $PRR \leq 1$ MHz, $t_r = t_f = 2$ ns, duty cycle = 50%.
 E. The outputs are measured one at a time with one transition per measurement.

Figure 1. Load Circuits and Voltage Waveforms



POST OFFICE BOX 655303 • DALLAS, TEXAS 75265