

REVISIONS			
LTR	DESCRIPTION	DATE	APPROVED
D	Change R _L to 2 kΩ. Convert to military drawing format Remove vendor, CAGE 27014.	16 Oct 1986	<i>Mickhauck</i>
E	Add footnote to table I. Change max frequency. Add LCC package. Add vendor CAGE 04713. Editorial changes throughout. Change logic diagram.	21 OCT. 1987	<i>P. Revans</i>

CURRENT CAGE CODE 67268

REV														
PAGE														
REV STATUS OF PAGES	REV	E	E	E	E	E	E	E	E	E	E	E	D	E
	PAGES	1	2	3	4	5	6	7	8	9	10	11	12	

Defense Electronics Supply Center Dayton, Ohio Original date of drawing: 17 May 1977 AMSC N/A	PREPARED BY <i>David W. Quinnan</i>	MILITARY DRAWING This drawing is available for use by all Departments and Agencies of the Department of Defense							
	CHECKED BY <i>Mickhauck</i>								
	APPROVED BY <i>Mickhauck</i>	TITLE: MICROCIRCUIT, DIGITAL, LOW POWER SCHOTTKY TTL, COUNTER, MONOLITHIC SILICON							
	<table border="1" style="width: 100%; border-collapse: collapse;"> <tr> <th style="width: 15%;">SIZE</th> <th style="width: 45%;">CODE IDENT. NO.</th> <th style="width: 40%;">DWG NO.</th> </tr> <tr> <td style="text-align: center;">A</td> <td style="text-align: center;">14933</td> <td style="text-align: center;">77010</td> </tr> </table>	SIZE	CODE IDENT. NO.	DWG NO.	A	14933	77010	<table border="1" style="width: 100%; border-collapse: collapse;"> <tr> <td style="width: 60%;">PAGE 1</td> <td style="width: 40%;">OF 12</td> </tr> </table>	PAGE 1
SIZE	CODE IDENT. NO.	DWG NO.							
A	14933	77010							
PAGE 1	OF 12								

5962-E484

DISTRIBUTION STATEMENT A. Approved for public release; distribution is unlimited.
DESC FORM 193
MAY 86

1. SCOPE

1.1 Scope. This drawing describes device requirements for class B microcircuits in accordance with 1.2.1 of MIL-STD-883, "Provisions for the use of MIL-STD-883 in conjunction with compliant non-JAN devices".

1.2 Part number. The complete part number shall be as shown in the following example:

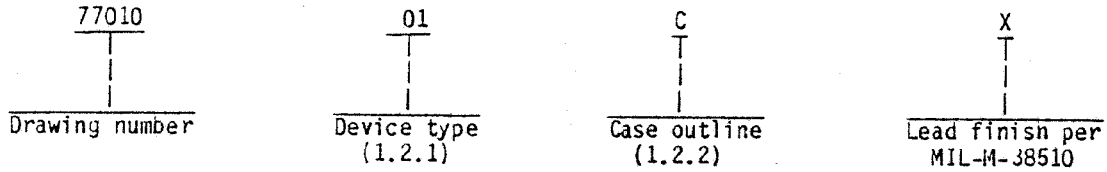

1.2.1 Device type. The device type shall identify the circuit function as follows:

Device type	Generic number	Circuit
01	54LS196	30 MHz presettable decade or binary counter

1.2.2 Case outlines. The case outlines shall be as designated in appendix C of MIL-M-38510, and as follows:

Outline letter	Case outline
C	D-1 (14-lead, 1/4" x 3/4"), dual-in-line package
D	F-2 (14-lead, 1/4" x 3/8"), flat-package
2	C-2 (20-terminal, .350" x .350"), square chip carrier package

1.3 Absolute maximum ratings.

Supply voltage range - - - - -	-0.5 V dc to +7.0 V dc
Input voltage range - - - - -	-1.5 V dc at -18 mA to 5.5 V dc
Storage temperature range - - - - -	-65°C to +150°C
Maximum power dissipation (P_D) 1/ - - - - -	149 mW
Lead temperature (soldering, 10 seconds) - - - - -	+300°C
Thermal resistance, junction-to-case (θ_{JC}) - - - - -	(See MIL-M-38510, appendix C)
Junction temperature (T_J) - - - - -	+175°C

1.4 Recommended operating conditions.

Supply voltage (V_{CC}) - - - - -	4.5 V dc minimum to 5.5 V dc maximum
Minimum high level input voltage (V_{IH}) - - - - -	2.0 V dc
Maximum low level input voltage (V_{IL}) - - - - -	0.7 V dc
Case operating temperature range (T_C) - - - - -	-55°C to +125°C

1/ Must withstand the added P_D due to short-circuit test (e.g., I_{OS}).

MILITARY DRAWING DEFENSE ELECTRONICS SUPPLY CENTER DAYTON, OHIO	SIZE	DWG NO	
	A	77010	
	REV	E	PAGE 2

2. APPLICABLE DOCUMENTS

2.1 Government specification and standard. Unless otherwise specified, the following specification and standard, of the issue listed in that issue of the Department of Defense Index of Specifications and Standards specified in the solicitation, form a part of this drawing to the extent specified herein.

SPECIFICATION

MILITARY

MIL-M-38510 - Microcircuits, General Specification for.

STANDARD

MILITARY

MIL-STD-883 - Test Methods and Procedures for Microelectronics.

(Copies of the specification and standard required by manufacturers in connection with specific acquisition functions should be obtained from the contracting activity or as directed by the contracting activity.)

3. REQUIREMENTS

3.1 Item requirements. The individual item requirements shall be in accordance with 1.2.1 of MIL-STD-883, "Provisions for the use of MIL-STD-883 in conjunction with compliant non-JAN devices" and as specified herein.

3.2 Design, construction, and physical dimensions. The design, construction, and physical dimensions shall be as specified in MIL-M-38510 and herein.

3.2.1 Terminal connections. The terminal connections shall be as specified on figure 1.

3.2.2 Logic diagram. The logic diagram shall be as specified on figure 2.

3.2.3 Truth table. The truth table shall be as specified on figure 3.

3.2.4 Case outlines. The case outlines shall be in accordance with 1.2.2 herein.

3.3 Electrical performance characteristics. Unless otherwise specified, the electrical performance characteristics are as specified in table I and apply over the full recommended case operating temperature range.

3.4 Marking. Marking shall be in accordance with MIL-STD-883 (see 3.1 herein). The part shall be marked with the part number listed in 1.2 herein. In addition, the manufacturer's part number may also be marked as listed in 6.4 herein.

3.5 Certificate of compliance. A certificate of compliance shall be required from a manufacturer in order to be listed as an approved source of supply in 6.4. The certificate of compliance submitted to DESC-ECS prior to listing as an approved source of supply shall state that the manufacturer's product meets the requirements of MIL-STD-883 (see 3.1 herein) and the requirements herein.

MILITARY DRAWING DEFENSE ELECTRONICS SUPPLY CENTER DAYTON, OHIO	SIZE		DWG NO.	
	A		77010	
	REV	E	PAGE	3

TABLE I. Electrical performance characteristics.

Test	Symbol	Conditions -55°C < T _C < +125°C, unless otherwise specified	Group A subgroups	Limits		Unit
				Min	Max	
High level output voltage	V _{OH}	V _{CC} = 4.5 V; V _{IN} = 0.7 V or 2.0 V I _{OH} = -400 μA	1,2,3	2.5		V
Low level output voltage	V _{OL}	V _{CC} = 4.5 V; V _{IN} = 0.7 V or 2.0 V I _{OL} = 4 mA	1,2,3		0.4	V
Input clamp voltage	V _{IC}	V _{CC} = 4.5 V; I _{IN} = -18 mA; T _C = +25°C	1		-1.5	V
High level input current	I _{IH1}	V _{CC} = 5.5 V Data, Count/Load V _{IH} = 2.7 V	1,2,3		20	μA
	I _{IH2}	V _{CC} = 5.5 V Clear, Clock 1 V _{IH} = 2.7 V Clock 2	1,2,3		40 80	μA μA
	I _{IH3}	V _{CC} = 5.5 V Data, Count/Load V _{IH} = 5.5 V	1,2,3		100	μA
	I _{IH4}	V _{CC} = 5.5 V Clear, Clock 1 V _{IH} = 5.5 V Clock 2	1,2,3		200 400	μA μA
Low level input current	I _{IL1}	V _{CC} = 5.5 V Data, Count/Load V _{IL} = 0.4 V	1,2,3		-400	μA
	I _{IL2}	V _{CC} = 5.5 V Clear V _{IL} = 0.4 V	1,2,3		-800	μA
	I _{IL3}	V _{CC} = 5.5 V Clock 1 V _{IL} = 0.4 V	1,2,3		-2.4	mA
	I _{IL4}	V _{CC} = 5.5 V Clock 2 V _{IL} = 0.4 V	1,2,3		-2.8	mA
Short-circuit output current	I _{OS}	V _{CC} = 5.5 V 1/	1,2,3	-6	-130	mA
Supply current	I _{CC}	V _{CC} = 5.5 V	1,2,3		27	mA
Functional tests		See 4.3.1c	7			

See footnotes at end of table.

MILITARY DRAWING DEFENSE ELECTRONICS SUPPLY CENTER DAYTON, OHIO	SIZE	DWG NO	
	A	77010	
		REV E	PAGE 4

TABLE I. Electrical performance characteristics - Continued.

Test	Symbol	Conditions -55°C < T _C < +125°C, unless otherwise specified	Group A subgroups	Limits		Unit
				Min	Max	
Maximum clock frequency Clock 1	F _{MAX}	V _{CC} = 5.0 V R _L = 2 kΩ ±5% C _L = 50 pF ±10% 2/	9	25		MHz
			10, 11	17		MHz
Propagation delay time Clock 1 to QA	t _{PLH1}		9		20	ns
			10, 11		28	ns
	t _{PHL1}		9		30	ns
			10, 11		35	ns
Propagation delay time Clock 2 to QB	t _{PLH2}	9		29	ns	
		10, 11		41	ns	
	t _{PHL2}	9		42	ns	
		10, 11		53	ns	
Propagation delay time Clock 2 to QC	t _{PLH3}	9		68	ns	
		10, 11		87	ns	
	t _{PHL3}	9		72	ns	
		10, 11		94	ns	
Propagation delay time, low-to-high level Clock 2 to QD	t _{PLH4}	9		23	ns	
		10, 11		32	ns	

See footnotes at end of table.

MILITARY DRAWING DEFENSE ELECTRONICS SUPPLY CENTER DAYTON, OHIO	SIZE		DWG NO.	
	A		77010	
	REV	E	PAGE	5

TABLE I. Electrical performance characteristics - Continued.

Test	Symbol	Conditions -55°C ≤ T _C ≤ +125°C, unless otherwise specified	Group A subgroups	Limits		Unit
				Min	Max	
Propagation delay time, high-to-low level Clock 2 to QD	t _{PHL4}	V _{CC} = 5.0 V R _L = 2 kΩ ±5% C _L = 50 pF ±10% 2/	9		54	ns
			10, 11		70	ns
Propagation delay time A, B, C, D to QA, QB, QC, QD	t _{PLH5}		9		35	ns
			10, 11		49	ns
	t _{PHL5}		9		53	ns
			10, 11		69	ns
Propagation delay time Load to any output	t _{PLH6}	9		45	ns	
		10, 11		64	ns	
	t _{PHL6}	9		54	ns	
		10, 11		70	ns	
Propagation delay time, high-to-low level Clear to any output	t _{PHL7}	9		60	ns	
		10, 11		78	ns	

1/ Not more than one output should be shorted at a time, and the duration of the short-circuit condition should not exceed 1 second.
 2/ Propagation delay time testing may be performed using either C_L = 15 pF or C_L = 50 pF. However, the manufacturer must certify and guarantee that the microcircuits meet the switching test limits specified for a 50-pF load.

MILITARY DRAWING DEFENSE ELECTRONICS SUPPLY CENTER DAYTON, OHIO	SIZE		DWG NO.	
	A		77010	
		REV	E	PAGE

Cases C and D

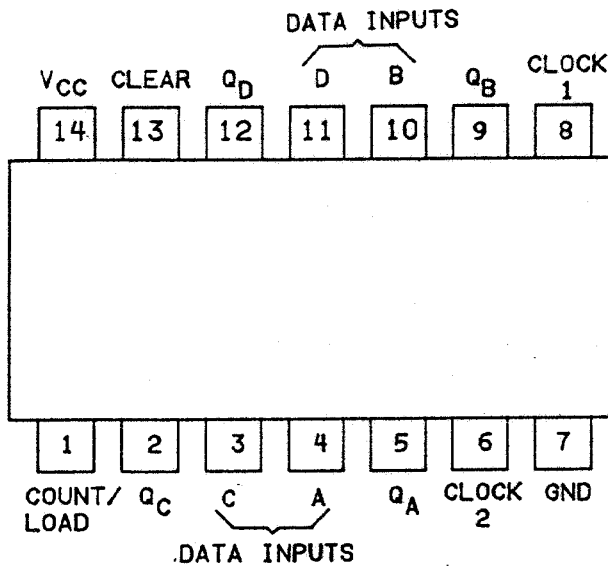

Case 2

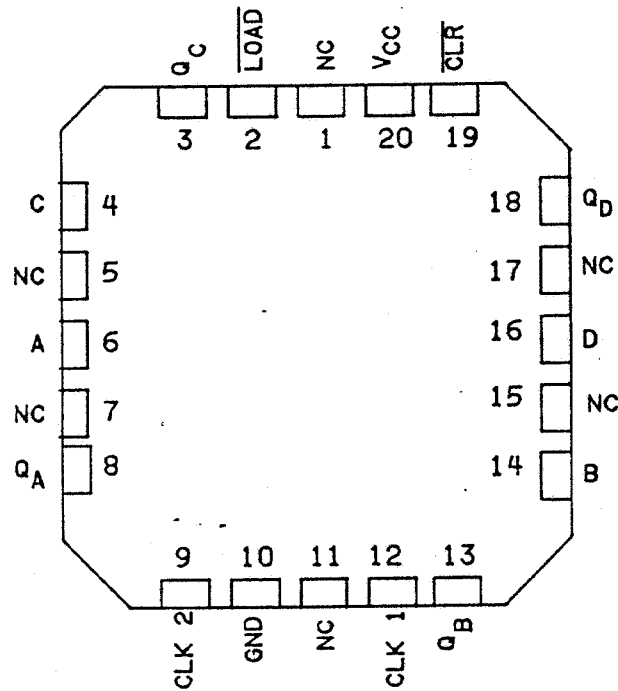

FIGURE 1. Terminal connections.

MILITARY DRAWING

DEFENSE ELECTRONICS SUPPLY CENTER
DAYTON, OHIO

SIZE
A

DWG NO.
77010

REV E

PAGE 7

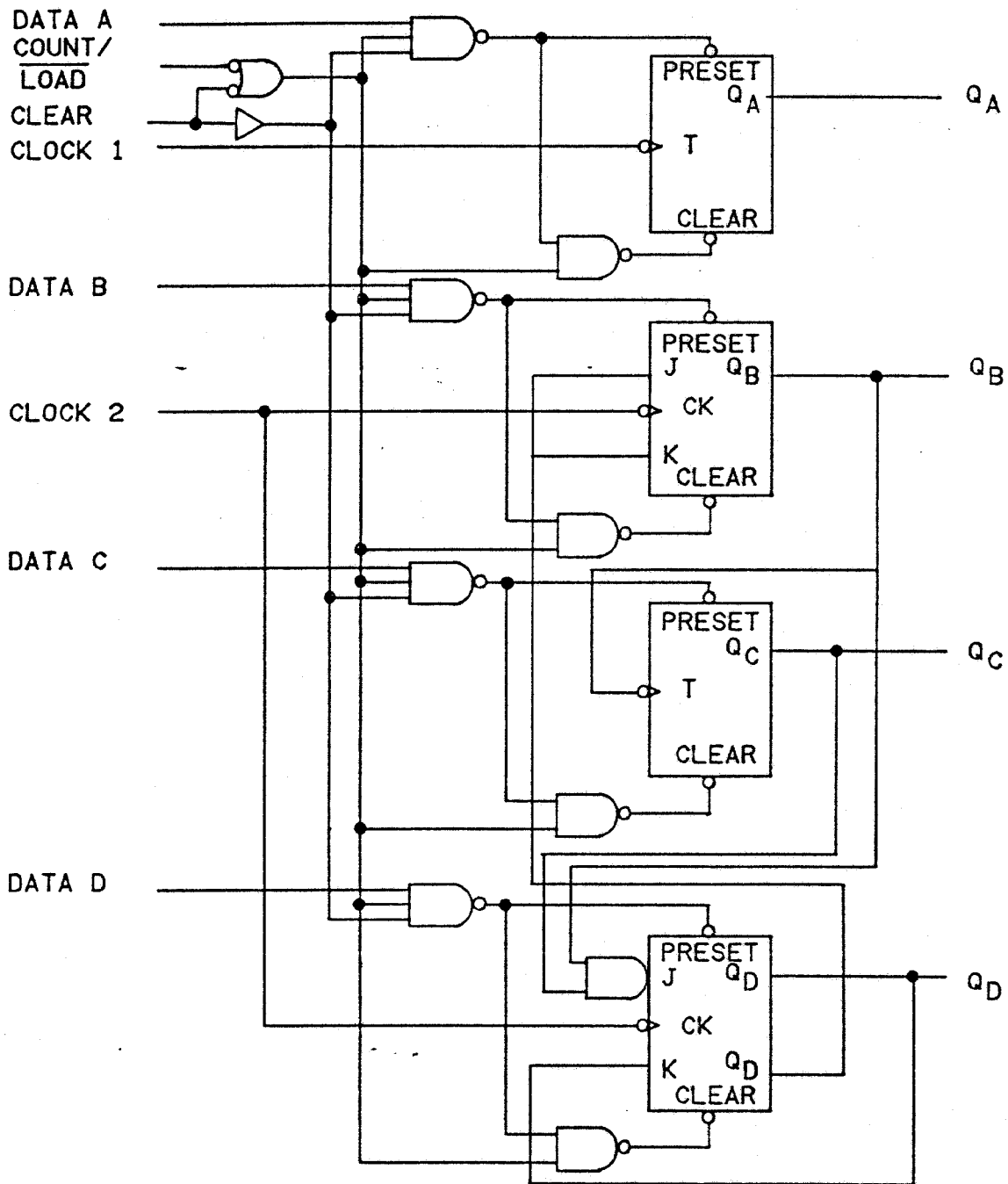

FIGURE 2. Logic diagram.

MILITARY DRAWING DEFENSE ELECTRONICS SUPPLY CENTER DAYTON, OHIO	SIZE		DWG NO.	
	A		77010	
		REV	E	PAGE 8

Count	Output			
	Q _D	Q _C	Q _B	Q _A
0	L	L	L	L
1	L	L	L	H
2	L	L	H	L
3	L	L	H	H
4	L	H	L	L
5	L	H	L	H
6	L	H	H	L
7	L	H	H	H
8	H	L	L	L
9	H	L	L	H

H = High level, L = Low level

NOTE: Output Q_A connected to Clock 2 input.

FIGURE 3. Truth table.

MILITARY DRAWING DEFENSE ELECTRONICS SUPPLY CENTER DAYTON, OHIO	SIZE		DWG NO.
	A		77010
	REV	E	PAGE 9

3.6 Certificate of conformance. A certificate of conformance as required in MIL-STD-883 (see 3.1 herein) shall be provided with each lot of microcircuits delivered to this drawing.

3.7 Notification of change. Notification of change to DESC-ECS shall be required in accordance with MIL-STD-883 (see 3.1 herein).

3.8 Verification and review. DESC, DESC's agent, and the acquiring activity retain the option to review the manufacturer's facility and applicable required documentation. Offshore documentation shall be made available onshore at the option of the reviewer.

4. QUALITY ASSURANCE PROVISIONS

4.1 Sampling and inspection. Sampling and inspection procedures shall be in accordance with section 4 of MIL-M-38510 to the extent specified in MIL-STD-883 (see 3.1 herein).

4.2 Screening. Screening shall be in accordance with method 5004 of MIL-STD-883, and shall be conducted on all devices prior to quality conformance inspection. The following additional criteria shall apply:

a. Burn-in test (method 1015 of MIL-STD-883).

(1) Test condition A, B, C, or D using the circuit submitted with the certificate of compliance (see 3.5 herein).

(2) $T_A = +125^\circ\text{C}$, minimum.

b. Interim and final electrical test parameters shall be as specified in table II herein, except interim electrical parameter tests prior to burn-in are optional at the discretion of the manufacturer.

4.3 Quality conformance inspection. Quality conformance inspection shall be in accordance with method 5005 of MIL-STD-883 including groups A, B, C, and D inspections. The following additional criteria shall apply.

4.3.1 Group A inspection.

a. Tests shall be as specified in table II herein.

b. Subgroups 4, 5, 6, and 8 in table I, method 5005 of MIL-STD-883 shall be omitted.

c. Subgroup 7 tests shall verify the truth table.

4.3.2 Groups C and D inspections.

a. End-point electrical parameters shall be as specified in table II herein.

b. Steady-state life test (method 1005 of MIL-STD-883) conditions:

(1) Test condition A, B, C, or D using the circuit submitted with the certificate of compliance (see 3.5 herein).

(2) $T_A = +125^\circ\text{C}$, minimum.

(3) Test duration: 1,000 hours, except as permitted by appendix B of MIL-M-38510 and method 1005 of MIL-STD-883.

MILITARY DRAWING DEFENSE ELECTRONICS SUPPLY CENTER DAYTON, OHIO	SIZE A	DWG NO. 77010
	REV E	PAGE 10

TABLE II. Electrical test requirements.

MIL-STD-883 test requirements	Subgroups (per method 5005, table I)
Interim electrical parameters (method 5004)	---
Final electrical test parameters (method 5004)	1*, 2, 3, 9
Group A test requirements (method 5005)	1, 2, 3, 7, 9, 10, 11**
Groups C and D end-point electrical parameters (method 5005)	1, 2, 3

* PDA applies to subgroup 1.

** Subgroups 10 and 11, if not tested, shall be guaranteed to the specified limits in table I.

5. PACKAGING

5.1 Packaging requirements. The requirements for packaging shall be in accordance with MIL-M-38510.

6. NOTES

6.1 Intended use. Microcircuits conforming to this drawing are intended for use when military specifications do not exist and qualified military devices that will perform the required function are not available for OEM application. When a military specification exists and the product covered by this drawing has been qualified for listing on QPL-38510, the device specified herein will be inactivated and will not be used for new design. The QPL-38510 product shall be the preferred item for all applications.

6.2 Replaceability. Replaceability is determined as follows:

- a. Microcircuits covered by this drawing will replace the same generic device covered by a contractor-prepared specification or drawing.
- b. When a QPL source is established, the part numbered device specified in this drawing will be replaced by the microcircuit identified as part number M38510/32001B--.

6.3 Comments. Comments on this drawing should be directed to DESC-ECS, Dayton, Ohio 45444, or telephone 513-296-5375.

MILITARY DRAWING DEFENSE ELECTRONICS SUPPLY CENTER DAYTON, OHIO	SIZE		DWG NO.	
	A		77010	
	REV	D	PAGE	11

6.4 Approved sources of supply. Approved sources of supply are listed herein. Additional sources will be added as they become available. The vendors listed herein have agreed to this drawing and a certificate of compliance (see 3.5) has been submitted to DESC-ECS.

Military drawing part number	Vendor CAGE number	Vendor similar part number <u>1/</u>	Replacement military specification part number
7701001CX <u>2/</u>	01295 04713	SNJ54LS196J 54LS196/BCAJC	M38510/32001BCX
7701001DX <u>2/</u>	01295	SNJ54LS196W	M38510/32001BDX
77010012X	01295 04713	SNJ54LS196FK 54LS196M/B2AJC	

- 1/ Caution. Do not use this number for item acquisition. Items acquired to this number may not satisfy the performance requirements of this drawing.
- 2/ Inactive for new design as of October 1984. Use QPL-38510 product.

Vendor CAGE number

Vendor name and address

01295

Texas Instruments, Incorporated
P.O. Box 6448
Midland, TX 79701

04713

Motorola, Incorporated
7402 South Price Road
Tempe, AZ 85283

MILITARY DRAWING DEFENSE ELECTRONICS SUPPLY CENTER DAYTON, OHIO	SIZE		DWG NO.
	A		77010
	REV	E	PAGE 12