

FAST 74F37

Buffer

Quad 2-Input NAND Buffer

FAST Products

FUNCTION TABLE

INPUTS		OUTPUT
D _{na}	D _{nb}	\bar{Q}_n
L	L	H
L	H	H
H	L	H
H	H	L

H = High voltage level
L = Low voltage level

LOGIC DIAGRAM

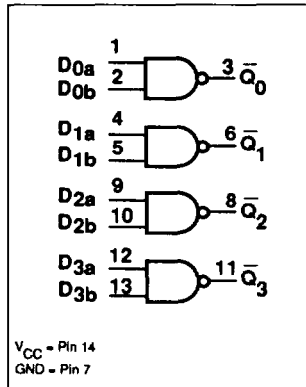

PIN CONFIGURATION

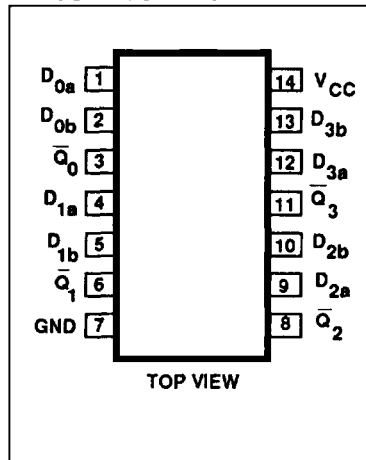

Product Specification

TYPE	TYPICAL PROPAGATION DELAY	TYPICAL SUPPLY CURRENT (TOTAL)
74F37	3.5 ns	13 mA

ORDERING INFORMATION

PACKAGES	COMMERCIAL RANGE $V_{CC} = 5V \pm 10\%$; $T_A = 0^\circ C$ to $+70^\circ C$
14-Pin Plastic DIP	N74F37N
14-Pin Plastic SO	N74F37D

INPUT AND OUTPUT LOADING AND FAN-OUT TABLE

PINS	DESCRIPTION	74F(U.L.) HIGH/LOW	LOAD VALUE HIGH/LOW
D _{na} , D _{nb}	Data inputs	1.0/2.0	20 μ A/1.2mA
\bar{Q}_n	Data output	750/106.6	15mA/64mA

NOTE:

One (1.0) FAST Unit Load is defined as: 20 μ A in the High state and 0.6mA in the Low state.

LOGIC SYMBOL

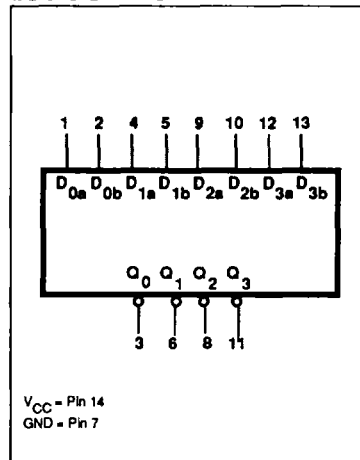

LOGIC SYMBOL (IEEE/IEC)

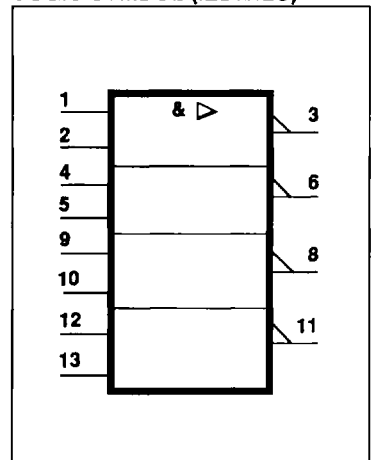

Buffer

FAST 74F37

ABSOLUTE MAXIMUM RATINGS (Operation beyond the limits set forth in this table may impair the useful life of the device. Unless otherwise noted these limits are over the operating free-air temperature range.)

SYMBOL	PARAMETER	RATING	UNIT
V_{CC}	Supply voltage	-0.5 to +7.0	V
V_{IN}	Input voltage	-0.5 to +7.0	V
I_{IN}	Input current	-30 to +5	mA
V_{OUT}	Voltage applied to output in High output state	-0.5 to + V_{CC}	V
I_{OUT}	Current applied to output in Low output state	128	mA
T_A	Operating free-air temperature range	0 to +70	°C
T_{STG}	Storage temperature	-65 to +150	°C

RECOMMENDED OPERATING CONDITIONS

SYMBOL	PARAMETER	LIMITS			UNIT
		Min	Nom	Max	
V_{CC}	Supply voltage	4.5	5.0	5.5	V
V_{IH}	High-level input voltage	2.0			V
V_{IL}	Low-level input voltage			0.8	V
I_{IK}	Input clamp current			-18	mA
I_{OH}	High-level output current			-15	mA
I_{OL}	Low-level output current			64	mA
T_A	Operating free-air temperature range	0		70	°C

DC ELECTRICAL CHARACTERISTICS (Over recommended operating free-air temperature range unless otherwise noted.)

SYMBOL	PARAMETER	TEST CONDITIONS ¹	LIMITS			UNIT	
			Min	Typ ²	Max		
V_{OH}	High-level output voltage	$V_{CC} = \text{MIN}$ $V_{IL} = \text{MAX}$ $V_{IH} = \text{MIN}$	$I_{OH} = -1\text{mA}$	$\pm 10\%V_{CC}$	2.5		V
				$\pm 5\%V_{CC}$	2.7	3.4	V
		$I_{OH} = -15\text{mA}$	$\pm 10\%V_{CC}$	2.0		V	
			$\pm 5\%V_{CC}$	2.0		V	
V_{OL}	Low-level output voltage	$V_{CC} = \text{MIN}$ $V_{IL} = \text{MAX}$ $V_{IH} = \text{MIN}$	$I_{OL} = \text{MAX}$	$\pm 10\%V_{CC}$		0.55	V
				$\pm 5\%V_{CC}$		0.42	0.55
V_{IK}	Input clamp voltage	$V_{CC} = \text{MIN}, I_I = I_{IK}$			-0.73	-1.2	V
I_I	Input current at maximum input voltage	$V_{CC} = \text{MAX}, V_I = 7.0\text{V}$				100	μA
I_{IH}	High-level input current	$V_{CC} = \text{MAX}, V_I = 2.7\text{V}$				20	μA
I_{IL}	Low-level input current	$V_{CC} = \text{MAX}, V_I = 0.5\text{V}$				-0.6	mA
I_{OS}	Short circuit output current	$V_{CC} = \text{MAX}$			-100	-225	mA
I_{CC}	Supply current (total)	$V_{CC} = \text{MAX}$	$V_{IN} = \text{GND}$		3.0	6.0	mA
				$V_{IN} = 4.5\text{V}$		23	33

NOTES:

- For conditions shown as MIN or MAX, use the appropriate value specified under recommended operating conditions for the applicable type.
- All typical values are at $V_{CC} = 5\text{V}$, $T_A = 25^\circ\text{C}$.
- Not more than one output should be shorted at a time. For testing I_{OS} , the use of high-speed test apparatus and/or sample-and-hold techniques are preferable in order to minimize internal heating and more accurately reflect operational values. Otherwise, prolonged shorting of a High output may raise the chip temperature well above normal and thereby cause invalid readings in other parameter tests. In any sequence of parameter tests, I_{OS} tests should be performed last.

Buffer

FAST 74F37

AC ELECTRICAL CHARACTERISTICS

SYMBOL	PARAMETER	TEST CONDITION	LIMITS					UNIT
			$T_A = +25^\circ\text{C}$ $V_{CC} = 5\text{V}$ $C_L = 50\text{pF}$ $R_L = 500\Omega$			$T_A = 0^\circ\text{C to } +70^\circ\text{C}$ $V_{CC} = 5\text{V} \pm 10\%$ $C_L = 50\text{pF}$ $R_L = 500\Omega$		
			Min	Typ	Max	Min	Max	
t_{PLH} t_{PHL}	Propagation delay D_{na}, D_{nb} to \bar{Q}_n	Waveform 1	2.5 1.5	3.5 2.5	5.5 4.5	2.0 1.5	6.5 5.0	ns

AC WAVEFORMS

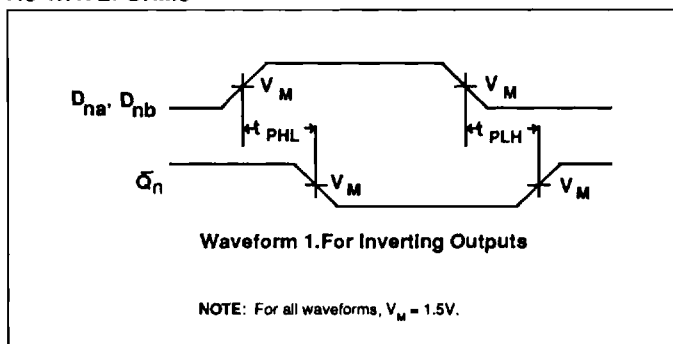

TEST CIRCUIT AND WAVEFORMS

