

- Designed to be Interchangeable with AMD's AM29825 and AM29826
- Improved IOH Specifications
- Multiple Output Enables Allow Multiuser Control of the Interface
- Outputs Have Undershoot Protection Circuitry
- Power-Up High Impedance State
- Package Options Include Plastic and Ceramic Chip Carriers in Addition to Plastic and Ceramic DIPs
- Buffered Control Inputs to Reduce DC Loading Effects
- Dependable Texas Instruments Quality and Reliability

**description**

These 8-bit flip-flops feature three-state outputs designed specifically for driving highly-capacitive or relatively low-impedance loads. They are particularly suitable for implementing multiuser registers, I/O ports, bidirectional bus drivers, and working registers.

With the clock enable ( $\overline{\text{CLKEN}}$ ) low, the eight D-type edge-triggered flip-flops enter data on the low-to-high transitions of the clock. Taking  $\overline{\text{CLKEN}}$  high will disable the clock buffer, thus latching the outputs. The 'AS29825 has noninverting D inputs and the 'AS29826 has inverting D inputs. Taking the  $\overline{\text{CLR}}$  input low causes the eight Q outputs to go low independently of the clock.

The buffered output-control inputs ( $\overline{\text{OC1}}$ ,  $\overline{\text{OC2}}$ , and  $\overline{\text{OC3}}$ ) can be used to place the eight outputs in either a normal logic state (high or low levels) or a high-impedance state. In the high-impedance state, the outputs neither load nor drive the bus lines significantly. The high-impedance state and increased drive provide the capability to drive the bus lines in a bus-organized system without need for interface or pull-up components. The output controls do not affect the internal operation of the flip-flops. Old data can be retained or new data can be entered while the outputs are in the high-impedance state.

SN54AS29825 . . . JT PACKAGE  
SN74AS29825 . . . DW OR NT PACKAGE  
(TOP VIEW)

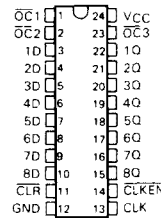

SN54AS29825 . . . FK PACKAGE  
SN74AS29825 . . . FN PACKAGE  
(TOP VIEW)

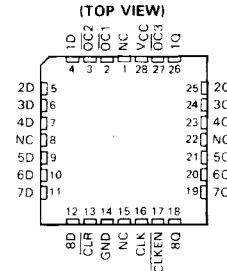

SN54AS29826 . . . JT PACKAGE  
SN74AS29826 . . . DW OR NT PACKAGE  
(TOP VIEW)

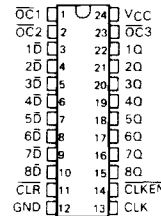

SN54AS29826 . . . FK PACKAGE  
SN74AS29826 . . . FN PACKAGE  
(TOP VIEW)

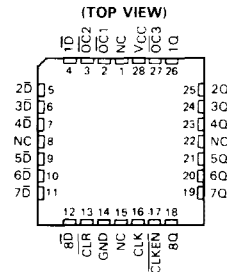

NC No internal connection

# SN54AS29825, SN54AS29826, SN74AS29825, SN74AS29826

## 8-BIT BUS INTERFACE FLIP-FLOPS WITH 3-STATE OUTPUTS

The SN54AS29825 and SN54AS29826 are characterized for operation over the full military temperature range of  $-55^{\circ}\text{C}$  to  $125^{\circ}\text{C}$ . The SN74AS29825 and SN74AS29826 are characterized for operation from  $0^{\circ}\text{C}$  to  $70^{\circ}\text{C}$ .

### FUNCTION TABLES

'AS29825					
INPUTS					OUTPUT
$\overline{\text{OC}}^*$	CLR	CLKEN	CLK	D	Q
L	L	X	X	X	L
L	H	L	$\uparrow$	H	H
L	H	L	$\uparrow$	L	L
L	H	H	X	X	$Q_0$
H	X	X	X	X	Z

'AS29826					
INPUTS					OUTPUT
$\overline{\text{OC}}^*$	CLR	CLKEN	CLK	$\overline{\text{D}}$	Q
L	L	X	X	X	L
L	H	L	$\uparrow$	H	L
L	H	L	$\uparrow$	L	H
L	H	H	X	X	$Q_0$
H	X	X	X	X	Z

$\overline{\text{OC}}^* = \text{H}$  if any of  $\overline{\text{OC}}1$ ,  $\overline{\text{OC}}2$ , or  $\overline{\text{OC}}3$  is high.  
 $\overline{\text{OC}}^* = \text{L}$  if all of  $\overline{\text{OC}}1$ ,  $\overline{\text{OC}}2$ , and  $\overline{\text{OC}}3$  are low.

### 'AS29825 logic symbol†

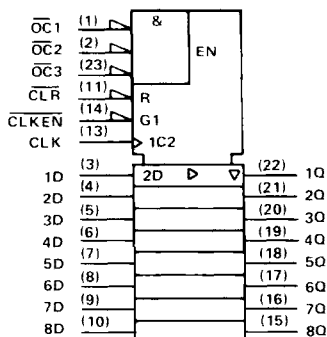

### 'AS29825 logic diagram (positive logic)

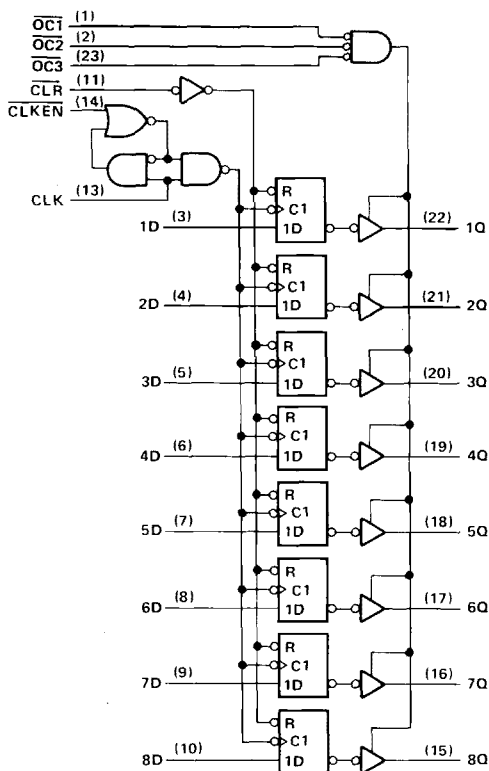

† This symbol is in accordance with ANSI/IEEE Std 91-1984 and IEC Publication 617-12.

Pin numbers shown are for DW, JT, and NT packages.

# SN54AS29826, SN74AS29826 8-BIT BUS INTERFACE FLIP-FLOPS WITH 3-STATE OUTPUTS

**AS29826 logic symbol†**

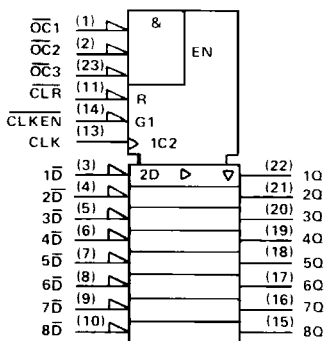

**AS29826 logic diagram (positive logic)**

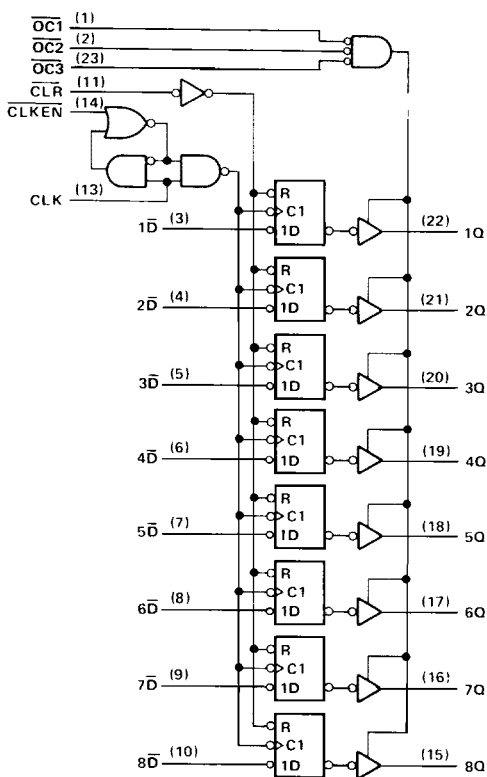

**2**  
ALS and AS Circuits

† This symbol is in accordance with ANSI/IEEE Std 91-1984 and IEC Publication 617-12.  
Pin numbers shown are for DW, JT, and NT packages.

