

OP-37

FEATURES:

- Replaces AD-510, 517, 725
..... PMI-OP27, OP37, OP07, OP05
..... Linear Tech. OP27, OP37, OP07
- Low Noise $.3nV/\sqrt{Hz}$ @ 1kHz
..... $80nV_{pp}$ (0.1Hz to 10Hz)
- Low Drift $0.2\mu V/^{\circ}C$
- Low V_{OS} $10\mu V$
- Slew Rate $17V/\mu S$
- High Open Loop Gain 1.8 Million
- Gain Bandwidth 63 MHz
- Superior CMRR 126dB @ V_{CM} of $\pm 11V$

DESCRIPTION:

The OP-37 provides the same high performance as the OP-27 but the design is optimized for circuits with gains greater than five. This design change increases slew rate to $17V/\mu s$ and gain-bandwidth product to 63MHz. The OP-37 operational amplifier combines outstanding low noise performance with precision D.C. characteristics and high speed operation. Wideband noise is $3nV/\sqrt{Hz}$ at 10Hz., with a low 1/f noise corner frequency of 2.7Hz. The OP-37's exceptionally low noise process allows for accurate high-gain amplification of low level signals. A gain-bandwidth product of 63MHz and a $17V/\mu sec$ slew rate provides an excellent choice for reliable,

precision amplifier applications. The low input bias current of 10nA and offset current of 7nA are achieved by using a bias-current-cancellation circuit. PSRR and CMRR exceed 120dB. These characteristics coupled with long-term drift of $0.2\mu V/month$, allow the circuit designer to achieve performance levels previously attained by discrete designs.

PRODUCT HIGHLIGHTS:

1. Precision amplification of very low level, low frequency voltage inputs is enhanced by ultra-low input voltage noise.
2. The OP-37 maintains high DC accuracy due to ultra-low offset voltage, offset voltage drift and input bias current.
3. Internal frequency compensation, factory adjusted offset voltage (zener-zapped) and full device protection eliminate the need for additional components.
4. Long-term stability and accuracy is assured with low offset voltage drift over time.
5. Input errors are greatly reduced by superior common mode and power supply rejection.
6. Radiation hardenable to beyond 5 M Rads.

SIMPLIFIED SCHEMATIC

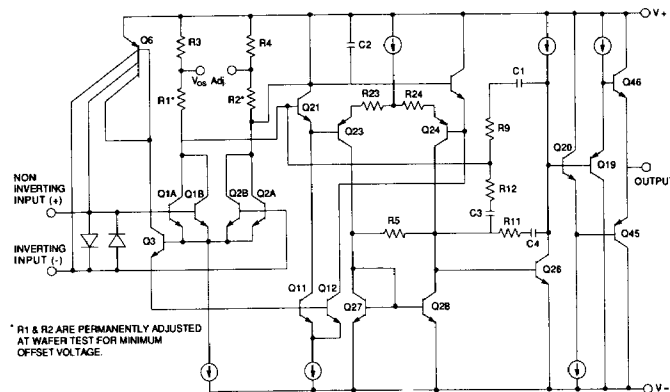

PIN CONNECTIONS (Top View)

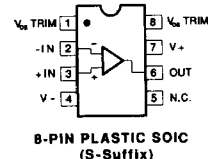
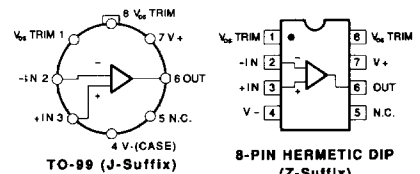

OP
Amps

ABSOLUTE MAXIMUM RATINGS (Note 4)

Supply Voltage	±22 V
Internal Power Dissipation (Note 1)	500mW
Input Voltage (Note 3)	±22V
Output Short-Circuit Duration	Indefinite
Differential Input Voltage (Note 2)	±0.7V
Differential Input Current (Note 2)	±25mA
Storage Temperature Range	-65°C to +150°C

Operating Temperature

Op-37E, Op-37F, Op-37G (P, S)	0°C to +70°C
Lead Temperature Range (Soldering, 60 sec)	300°C
DICE Junction Temperature	-65°C to +150°C

NOTES:

1. See table for maximum ambient temperature rating and derating factor.

PACKAGE TYPE	MAXIMUM AMBIENT TEMPERATURE FOR RATING	DERATE ABOVE MAXIMUM AMBIENT TEMPERATURE
T0-99 (J)	80°C	7.1mW/°C
8-Pin Plastic SOIC (S)	62°C	5.6mW/°C
8-Pin Plastic DIP (P)	62°C	5.7mW/°C
LCC	80°C	7.8mW/°C

- The OP-37's inputs are protected by back-to-back diodes. Current limiting resistors are not used in order to achieve low noise. If differential input voltage exceeds ±0.7V, the input current should be limited to 25mA.
- For supply voltages less than ±22V, the absolute maximum input voltage is equal to the supply voltage.
- Absolute maximum ratings apply to both DICE and packaged parts, unless otherwise noted.

ELECTRICAL CHARACTERISTICS at $V_S = \pm 15V$, $T_A = 25^\circ C$, unless otherwise noted.

PARAMETER	SYMBOL	CONDITIONS	OP-37A/E			OP-37B/F			OP-37C/G			UNITS
			MIN	TYP	MAX	MIN	TYP	MAX	MIN	TYP	MAX	
Input Offset Voltage	V_{OS}	OS (Note 1)	—	10	25	—	20	60	—	30	100	μV
Long-Term V_{OS} Stability	$V_{OS}/Time$	(Notes 2, 3)	—	0.2	1.0	—	0.3	1.5	—	0.4	2.0	$\mu V/Mo$
Input Offset Current	I_{OS}		—	7	35	—	9	50	—	12	75	nA
Input Bias Current	I_B		—	±10	±40	—	±12	±55	—	±15	±80	nA
Input Noise Voltage	e_{np-p}	0.1Hz to 10Hz (Notes 3, 5)	—	0.08	0.18	—	0.08	0.18	—	0.09	0.25	μV_{p-p}
Input Noise Voltage Density	e_n	$F_O = 10Hz$ (Note 3)	—	3.5	5.5	—	3.5	5.5	—	3.8	8.0	nV/\sqrt{Hz}
		$F_O = 30Hz$ (Note 3)	—	3.1	4.5	—	3.1	4.5	—	3.3	5.6	
		$F_O = 1000Hz$ (Note 3)	—	3.0	3.8	—	3.0	3.8	—	3.2	4.5	
Input Noise Current Density	i_n	$f_O = 10Hz$ (Notes 3, 6)	—	1.7	4.0	—	1.7	4.0	—	1.7	—	pA/\sqrt{Hz}
		$f_O = 30Hz$ (Notes 3, 6)	—	1.0	2.3	—	1.0	2.3	—	1.0	—	
		$f_O = 1000Hz$ (Notes 3, 6)	—	0.4	0.6	—	0.4	0.6	—	0.4	0.6	
Input Resistance — Differential-Mode	R_{IN}	(Note 7)	1.3	6	—	0.94	5	—	0.7	4	—	M Ω
Input Resistance — Common-Mode	R_{INCM}		—	3	—	—	2.5	—	—	2	—	G Ω
Input Voltage Range	I_{VR}		±11.0	±12.3	—	±11.0	±12.3	—	±11.0	±12.3	—	V
Common-Mode Rejection Ratio	CMRR	$V_{CM} = \pm 11V$	114	126	—	106	123	—	100	120	—	dB
Power Supply Rejection Ratio	PSSR	$V_S \pm 4V$ to $\pm 18V$	—	1	10	—	1	10	—	2	20	$\mu V/V$
Large-Signal Voltage Gain	A_{VO}	$R_L \geq 2k\Omega$, $V_O = \pm 10V$	1000	1800	—	1000	1800	—	700	1500	—	V/mV
		$R_L \geq 1k\Omega$, $V_O = \pm 10V$	800	1500	—	800	1500	—	400	1500	—	
		$R_L = 600\Omega$, $V_O \pm 1V$, $V_S = \pm 4V$, (Note 4)	250	700	—	250	700	—	200	500	—	
Output Voltage Swing	V_O	$R_L \geq 2k\Omega$ $R_L \geq 600\Omega$	±12.0	±13.8	—	±12.0	±13.8	—	±11.5	±13.5	—	V
Slew Rate	SR	$R_L \geq 2k\Omega$ (Note 4)	11	17	—	11	17	—	11	17	—	V/ μs
		$f_O = 10kHz$ (Note 4)	45	63	—	45	63	—	45	63	—	Mhz
Gain Bandwidth Prod.	GBW	$f_O = 1MHz$	—	40	—	—	40	—	—	40	—	
Open-Loop Output Resistance	R_O	$V_O = 0$, $I_O = 0$	—	70	—	—	70	—	—	70	—	Ω
Power Consumption	P_d	$V_O = 0$	—	90	140	—	90	140	—	100	170	mW
Offset Adjustment Range	R_p	$R_p = 10k\Omega$	—	±4.0	—	—	±4.0	—	—	±4.0	—	mV

NOTES:

- Input offset voltage measurements are performed by automated test equipment approximately 0.5 seconds after application of power. A/E grades guaranteed fully warmed up.
- Long-term input offset voltage stability refers to the average trend line of V_{OS} vs. Time over extended periods after the first 30 days of operation. Excluding the initial hour of operation, changes in V_{OS} during the first 30

- days are typically $2.5\mu V$ — refer to typical performance curve.
- Sample tested.
- Guaranteed by design.
- See test circuit and frequency response curve for 0.1Hz tester.
- See test circuit for current noise measurement.
- Guaranteed by input bias current.

ELECTRICAL CHARACTERISTICS for $V_S = \pm 15V$, $-25^\circ C \leq T_A \leq +85^\circ C$ for OP-37J, $0^\circ C \leq T_A \leq +70^\circ C$ for OP-37P, unless otherwise noted.

PARAMETER	SYMBOL	CONDITIONS	OP-37E			OP-37F			O-37G			UNITS
			MIN	TYP	MAX	MIN	TYP	MAX	MIN	TYP	MAX	
Input Offset Voltage	V_{OS}		—	20	50	—	40	140	—	55	220	μV
Average Input Offset Drift	TCV_{OS} TCV_{OSn}	(Note 2) (Note 3)	—	0.2	0.6	—	0.3	1.3	—	0.4	1.8	$\mu V/^\circ C$
Input Offset Current	i_{OS}		—	10	50	—	14	85	—	20	135	nA
Input Bias Current	I_B		—	± 14	± 60	—	± 18	± 95	—	± 25	± 150	nA
Input Voltage Range	IVR		± 10.5	± 11.8	—	± 10.5	± 11.8	—	± 10.5	± 11.8	—	V
Common-Mode Rejection Ratio	CMRR	$V_{CM} = \pm 10V$	110	124	—	102	121	—	96	118	—	dB
Power Supply Rejection Ratio	PSRR	$V_S = \pm 4.5V$ to $\pm 18V$	—	2	15	—	2	16	—	2	32	$\mu V/V$
Large-Signal Voltage Gain	A_{VO}	$R_L \geq 2k\Omega$, $V_O = \pm 10V$	750	1500	—	700	1300	—	450	1000	—	V/mV
Output Voltage Swing	V_O	$R_L \geq 2k\Omega$	± 11.7	± 13.6	—	± 11.4	± 13.5	—	± 11.0	± 13.3	—	V

NOTES:

1. Input offset voltage measurements are performed by automated test equipment approximately 0.5 seconds after application of power. A/E grades guaranteed fully warmed up.

2. The TCV_{OS} performance is within the specifications unnullled or when nullled with $R_p = 8k\Omega$ to $20k\Omega$. TCV_{OS} is 100% tested for A/E grades, sample tested for B/C/F/G grades.

3. Guaranteed by design.

DICE CHARACTERISTICS

DIE SIZE 0.057x0.099 inch, 5643 sq. mils
(1.44x2.515mm, 3.62 sq. mm)

For additional DICE information contact factory.

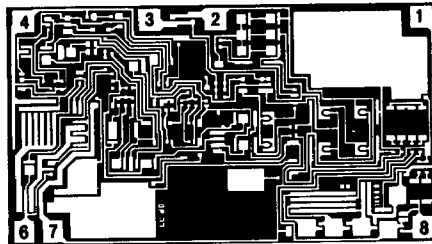

- 1. NULL
- 2. (-) INPUT
- 3. (+) INPUT
- 4. V-
- 6. OUTPUT
- 7. V+
- 8. NULL

WAFER TEST LIMITS at $V_S = \pm 15V$, $T_A = 25^\circ C$ for OP-37N, OP-37G and OP-37GR devices; unless otherwise noted.

PARAMETER	SYMBOL	CONDITIONS	OP-37NT LIMIT	OP-37N LIMIT	OP-37GT LIMIT	OP-37G LIMIT	OP-37GR LIMIT	UNITS
Input Offset Voltage	V_{OS}	(Note 1)	60	35	200	60	100	μV MAX
Input Offset Current	I_{OS}		50	35	85	50	75	nA MAX
Input Bias Current	I_B		± 60	± 40	± 95	± 55	± 80	nA MAX
Input Voltage Range	IVR		± 10.3	± 11	± 10.3	± 11	± 11	V MIN
Common-Mode Rejection Ratio	CMRR	$V_{CM} = \pm 11V$	108	114	100	106	100	dB MIN
Power Supply Rejection Ratio	PSRR	$T_A = 25^\circ C$, $V_S = \pm 4V$ to $\pm 18V$	10	10	10	10	20	$\mu V/V$ MAX
		$T_A = 125^\circ C$, $V_S = \pm 4V$ to $\pm 18V$	16	—	20	—	—	
Large-Signal Voltage Gain	A_{VO}	$R_L \geq 2k\Omega$, $V/O = \pm 10V$	600	1000	500	1000	700	V/mV MIN
		$R_L \geq 1k\Omega$, $V_O = \pm 10V$	—	800	—	800	—	
Output Voltage Swing	V_O	$R_L \geq 2k\Omega$	± 11.5	± 12.0	± 11.0	± 12.0	± 11.5	V MIN
		$R_L \geq 600\Omega$	—	± 10.0	—	± 10.0	± 10.0	
Power Consumption	P_d	$V_O = 0$	—	140	—	140	170	mW MAX

NOTES:

1. For $25^\circ C$ characteristics of OP-37NT and OP-37GT devices, see OP-37N and OP-37G characteristics, respectively.

Electrical tests are performed at wafer probe to the limits shown. Due to

variations in assembly methods and normal yield after packaging is not guaranteed for standard product dice. Consult factory to negotiate specifications based on dice lot qualification through sample lot assembly and testing

TYPICAL ELECTRICAL CHARACTERISTICS at $V_S = \pm 15V$, $T_A = 25^\circ C$, unless otherwise noted.

PARAMETER	SYMBOL	CONDITIONS	OP-37NT TYPICAL	OP-37N TYPICAL	OP-37GT TYPICAL	OP-37G TYPICAL	OP-37GR TYPICAL	UNITS
Average Input Offset Voltage Drift	TCV_{OS} or TCV_{OSn}	Null'd or Unnull'd $R_p = 8k\Omega$ to $20k\Omega$	0.2	0.2	0.3	0.3	0.4	$\mu V/^\circ C$
Average Input Offset Current Drift	TCI_{OS}		80	80	130	130	180	pA/°C
Average Input Bias Current Drift	TCI_B		100	100	160	160	200	pA/°C
Input Noise Voltage Density	e_n	$f_o = 10Hz$	3.5	3.5	3.5	3.5	3.8	nV \sqrt{Hz}
		$f_o = 30Hz$	3.1	3.1	3.1	3.1	3.3	
		$f_o = 1000Hz$	3.0	3.0	3.0	3.0	3.2	
Input Noise Current Density	i_n	$f_o = 10Hz$	1.7	1.7	1.7	1.7	1.7	pA \sqrt{Hz}
		$f_o = 30Hz$	1.0	1.0	1.0	1.0	1.0	
		$f_o = 1000Hz$	0.4	0.4	0.4	0.4	0.4	
Input Noise Voltage	e_{np-p}	0.1Hz to 10Hz	0.08	0.08	0.08	0.08	0.09	μV_{p-p}
Slew Rate	SR	$R_L \geq 2k\Omega$	17	17	17	17	17	V/ μs
Gain Bandwidth Product	GBW	$f_o = 10KHz$	63	63	63	63	63	MHz

NOTES:

1. Input offset voltage measurements are performed by automated test equipment approximately 0.5 seconds after application of power.

ORDERING INFORMATION

$T_A = 25^\circ C$ V_{OSMAX} (μV)	PACKAGE			OPERATING TEMP RANGE
	HERMETIC TO-99 8-PIN	PLASTIC DIP 8-PIN	PLASTIC SO-JEDEC 8-PIN	
25	OP37EJ	OP37EP	OP37ES	IND./COM.
60	OP37FJ	OP37FP	OP37FS	IND./COM.
100	OP37GJ	OP37GP	OP37GS	IND./COM.

*For devices processed in total compliance to MIL-STD-883, add/883 after part number. Consult factory for 883 data sheet.

All commercial and industrial temperature range parts are available with burn-in. For ordering information call the factory.