

The documentation and process conversion measures necessary to comply with this revision shall be completed by 20 October 2007.

INCH-POUND
MIL-PRF-19500/608C
20 July 2007
SUPERSEDING
MIL-PRF-19500/608B
17 August 2005

PERFORMANCE SPECIFICATION SHEET

SEMICONDUCTOR DEVICE, DIODE, SILICON, SCHOTTKY, POWER RECTIFIER, COMMON CATHODE, COMMON ANODE CENTER TAP, DOUBLER, TYPES 1N6660, 1N6660CCT1, 1N6660R, 1N6660CAT1, AND 1N6660DT1, JAN, JANTX, JANTXV, AND JANS

This specification is approved for use by all Departments and Agencies of the Department of Defense.

The requirements for acquiring the product described herein shall consist of this specification sheet and MIL-PRF-19500.

1. SCOPE

1.1 Scope. This specification covers the performance requirements for a silicon, schottky, power rectifier diodes. Four levels of product assurance are provided for each device type as specified in MIL-PRF-19500.

1.2 Physical dimensions. See figure 1 (TO-254AA isolated).

1.3 Maximum ratings. $T_A = +25^\circ\text{C}$, unless otherwise indicated.

Type	V_R (1)	V_{RWM} (1)	I_O (1) (2) (3) $T_C = 100^\circ\text{C}$	I_{FSM} (1) $T_C = +25^\circ\text{C}$ $t_p = 8.3 \text{ ms}$	C_J (1) at 5 V	T_{STG} & T_J	$R_{\theta JC}$ (1) (4) Die 1	$R_{\theta JC}$ (1) (4) Die 2
	V	V	A dc	A(pk)	pF	$^\circ\text{C}$	$^\circ\text{C/W}$	$^\circ\text{C/W}$
1N6660 1N6660CCT1	45	45	15	300	2,000	-65 to +150	1.65	1.65
1N6660R 1N6660CAT1							2.8	2.8
1N6660DT1							2.8	1.65

- (1) Each individual diode.
- (2) For derating see figures 2 and 3.
- (3) Total package current is limited to 30 A dc.
- (4) For thermal impedance graphs see figures 4 and 5.

1.4 Primary electrical characteristics. $R_{\theta JC}$ (entire package) = 0.85°C/W maximum for 1N6660CCT1. $R_{\theta JC}$ (entire package) = 1.5°C/W maximum for 1N6660CAT1 and 1N6660DT1. $R_{\theta JA} = 40^\circ\text{C/W}$ maximum, each individual diode.

Comments, suggestions, or questions on this document should be addressed to Defense Supply Center, Columbus, ATTN: DSCC-VAC, P.O. Box 3990, Columbus, OH 43218-3990, or emailed to semiconductor@dsc.dla.mil. Since contact information can change, you may want to verify the currency of this address information using the ASSIST Online database at <http://assist.daps.dla.mil>.

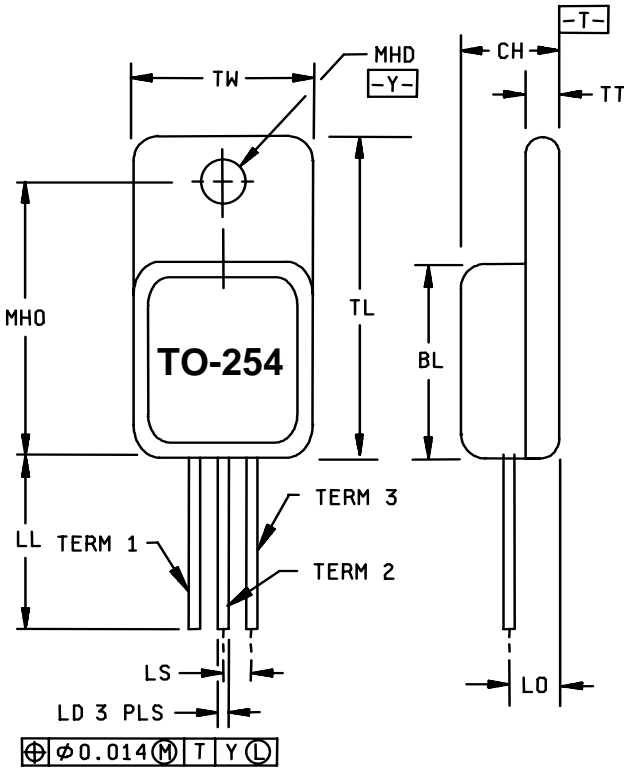

Ltr	Dimensions			
	Inches		Millimeters	
	Min	Max	Min	Max
BL	.535	.545	13.59	13.84
CH	.249	.260	6.32	6.60
LD	.035	.045	0.89	1.14
LL	.510	.570	12.95	14.48
LO	.150 BSC		3.81 BSC	
LS	.150 BSC		3.81 BSC	
MHD	.139	.149	3.53	3.78
MHO	.665	.685	16.89	17.40
TL	.790	.800	20.07	20.32
TT	.040	.050	1.02	1.27
TW	.535	.545	13.59	13.84

NOTES:

1. Dimensions are in inches
2. Millimeters are given for general information only.
3. All terminals are isolated from case.
4. In accordance with ASME Y14.5M, diameters are equivalent to Φ x symbology.

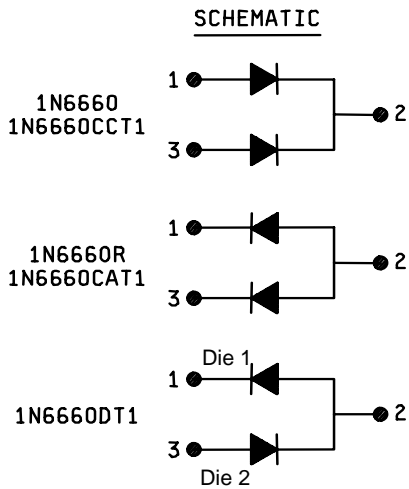

Types 1N6660CCT1, 1N6660R, 1N6660CAT1, and 1N6660DT1

FIGURE 1. Physical dimensions and configuration (TO-254AA).

2. APPLICABLE DOCUMENTS

2.1 General. The documents listed in this section are specified in sections 3, 4, or 5 of this specification. This section does not include documents cited in other sections of this specification or recommended for additional information or as examples. While every effort has been made to ensure the completeness of this list, document users are cautioned that they must meet all specified requirements of documents cited in sections 3, 4, or 5 of this specification, whether or not they are listed.

2.2 Government documents.

2.2.1 Specifications, standards, and handbooks. The following specifications, standards, and handbooks form a part of this document to the extent specified herein. Unless otherwise specified, the issues of these documents are those cited in the solicitation or contract.

DEPARTMENT OF DEFENSE SPECIFICATIONS

MIL-PRF-19500 - Semiconductor Devices, General Specification for.

DEPARTMENT OF DEFENSE STANDARDS

MIL-STD-750 - Test Methods for Semiconductor Devices.

(Copies of these documents are available online at <http://assist.daps.dla.mil/quicksearch/> or <http://assist.daps.dla.mil> or from the Standardization Document Order Desk, 700 Robbins Avenue, Building 4D, Philadelphia, PA 19111-5094.)

2.3 Order of precedence. In the event of a conflict between the text of this document and the references cited herein, the text of this document takes precedence. Nothing in this document, however, supersedes applicable laws and regulations unless a specific exemption has been obtained.

3. REQUIREMENTS

3.1 General. The individual item requirements shall be as specified in MIL-PRF-19500 and as modified herein.

3.2 Qualification. Devices furnished under this specification shall be products that are manufactured by a manufacturer authorized by the qualifying activity for listing on the applicable qualified manufacturers list before contract award (see 4.2 and 6.3).

3.3 Abbreviations, symbols, and definitions. Abbreviations, symbols, and definitions used herein shall be as specified in MIL-PRF-19500.

3.4 Interface requirements and physical dimensions. The interface requirements and physical dimensions shall be as specified in MIL-PRF-19500 and on figure 1 (TO-254AA) herein. Methods used for electrical isolation of the terminal feedthroughs shall employ materials that contain a minimum of 90 percent Al₂O₃ (ceramic).

3.4.1 Lead material, finish, and formation. Lead material shall be Kovar or Alloy 52; a copper core or plated core is permitted. Lead finish shall be solderable in accordance with MIL-PRF-19500, MIL-STD-750, and herein. Where a choice of lead formation, material, or finish is desired, it shall be specified in the acquisition document (see 6.2). When lead formation is performed, as a minimum, the vendor shall perform 100 percent hermetic seal in accordance with screen 14 of table E-IV of MIL-PRF-19500 and 100 percent dc testing in accordance with table I, subgroup 2 herein.

3.4.2 Polarity. Polarity and terminal configuration shall be in accordance with figure 1 herein.

3.5 Electrical performance characteristics. Unless otherwise specified herein, the electrical performance characteristics are as specified in 1.3, 1.4, and table I.

3.6 Electrical test requirements. The electrical test requirements shall be as specified in tables I and II.

3.7 Marking. Marking shall be in accordance with MIL-PRF-19500. The 1N6660CCT1 and 1N6660CAT1 are directly substitutable for the 1N6660 and 1N6660R, respectively.

3.8 Workmanship. Semiconductor devices shall be processed in such a manner as to be uniform in quality and shall be free from other defects that will affect life, serviceability, or appearance.

4. VERIFICATION

4.1 Classification of inspections. The inspection requirements specified herein are classified as follows:

- a. Qualification inspection (see 4.2).
- b. Screening (see 4.3).
- c. Conformance inspection (see 4.4 and tables I and II herein).

4.2 Qualification inspection. Qualification inspection shall be in accordance with MIL-PRF-19500 and as specified herein.

4.2.1 Group E qualification. Group E inspection shall be performed for qualification or re-qualification only. In case qualification was awarded to a prior revision of the specification sheet that did not require the performance of table III tests, the tests specified in table III herein that were not performed in the prior revision shall be performed on the first inspection lot of this revision to maintain qualification.

4.3 Screening (JANS, JANTXV, and JANTX levels only). Screening shall be in accordance with table E-IV of MIL-PRF-19500 and as specified herein. The following measurements shall be made in accordance with table I herein. Devices that exceed the limits of table I herein shall not be acceptable.

Screen (see table E-IV of MIL-PRF-19500)	Measurement	
	JANS level	JANTX and JANTXV levels
3b	Condition A, one pulse, $I_O = 0$, $V_{RWM} = 0$, $I_{FSM} =$ see 1.3 herein.	Condition A, one pulse, $I_O = 0$, $V_{RWM} = 0$, $I_{FSM} =$ see 1.3 herein.
(1) 3c	Thermal impedance (see 4.3.2)	Thermal impedance (see 4.3.2)
3d	Peak reverse energy test (see 4.3.3)	Peak reverse energy test (see 4.3.3)
4	Required	Not applicable
5, 8	Required	Not applicable
9, 10	Not applicable	Not applicable
11	V_{F1} and I_{R1}	V_{F1} and I_{R1}
12	See 4.3.1	See 4.3.1, $t = 48$ hours.
13	Subgroups 2 and 3 of table I herein excluding thermal impedance; V_{F1} and I_{R1} ; $\Delta V_{F1} = \pm 50$ mV (pk); $\Delta I_{R1} = \pm 25$ μ A dc or 100 percent from the initial value, whichever is greater.	Subgroup 2 of table I herein excluding thermal impedance; V_{F1} and I_{R1} ; $\Delta V_{F1} = \pm 50$ mV (pk); $\Delta I_{R1} = \pm 25$ μ A dc or 100 percent from the initial value, whichever is greater.
15	Required	Not applicable

(1) Shall be performed anytime after temperature cycling, screen 3a; does not need to be repeated in screening requirements.

4.3.1 Power burn-in conditions. Burn-in conditions are as follows: Method 1038 of MIL-STD-750, test condition A. $T_C = +125^\circ\text{C}$; $V_R = 36 \text{ V dc}$.

4.3.2 Thermal impedance measurements. The thermal impedance measurements shall be performed in accordance with method 3101 or 4081 as applicable of MIL-STD-750 using the guidelines in that method for determining I_H and I_M . The thermal impedance limit shall comply with the thermal impedance graphs in figures 4 and 5 (less than or equal to the curve value at the same t_H time) and shall be less than the process determined statistical maximum limit as outlined in method 3101 of MIL-STD-750. See group E, subgroup 4 of table III herein.

4.3.3 Peak reverse energy test. The peak reverse energy test is to be performed using the circuit as shown on figure 6 or equivalent. The Schottky rectifier under test shall be capable of absorbing the reverse energy, as follows: $I_{RM} = 2 \text{ A}$ minimum, $L = 260 \mu\text{H}$.

4.4 Conformance inspection. Conformance inspection shall be in accordance with MIL-PRF-19500.

4.4.1 Group A inspection. Group A inspection shall be conducted in accordance with table E-V of MIL-PRF-19500, and table I herein. Electrical measurements (end-points) and delta requirements shall be in accordance with the applicable steps of table II herein.

4.4.2 Group B inspection. Group B inspection shall be conducted in accordance with the conditions specified for subgroup testing in tables E-VIa (JANS) and E-VIb (JAN, JANTX, and JANTXV) of MIL-PRF-19500 and as follows. Electrical measurements (end-points) shall be in accordance with table I, subgroup 2, forward voltage test (V_{F1}) and reverse leakage test (I_{R1}) herein. Delta measurements shall be in accordance with table II herein.

4.4.2.1 Group B inspection, table E-VIa (JANS) of MIL-PRF-19500.

<u>Subgroup</u>	<u>Method</u>	<u>Condition</u>
B4	1037	$\Delta T_C = +85^\circ\text{C}$, $I_F = 2 \text{ A}$ minimum for 2,000 cycles.
B5	1038	Condition A, $V_R = 36\text{V dc}$, $T_J = 125^\circ\text{C}$, $t = 240 \text{ hours min}$; (heat sinking allowed).
B6	3101	1N6660CAT1, 1N6660DT1 (die 1), $R_{\theta JC} = 2.8^\circ\text{C/W}$ maximum for each leg 1N6660CCT1, 1N6660DT1 (die 2), $R_{\theta JC} = 1.65^\circ\text{C/W}$ maximum for each leg

4.4.2.2 Group B inspection, table E-VIb (JAN, JANTX, and JANTXV) of MIL-PRF-19500.

<u>Subgroup</u>	<u>Method</u>	<u>Condition</u>
B3	1037	$\Delta T_C = +85^\circ\text{C}$ minimum, $I_F = 2 \text{ A}$ minimum for 2,000 cycles.

* 4.4.3 Group C inspection. Group C inspection shall be conducted in accordance with the conditions specified for subgroup testing in table E-VII of MIL-PRF-19500. Electrical measurements (end-points) shall be in accordance with table I, subgroup 2, forward voltage test (V_{F1}) and reverse leakage test (I_{R1}) herein. Delta measurements shall be in accordance with table II herein.

<u>Subgroup</u>	<u>Method</u>	<u>Condition</u>
C2	2036	Condition A, weight = 20 lbs, $t = 15 \text{ seconds}$.
C6	1037	$\Delta T_C = +85^\circ\text{C}$, $I_F = 2 \text{ A}$ minimum for 6,000 cycles.

MIL-PRF-19500/608C

4.4.4 Group E inspection. Group E inspection shall be conducted in accordance with the tests and conditions specified for subgroup testing in table E-IX of MIL-PRF-19500, and table III herein. Electrical measurements (end-points) shall be in accordance with table I, subgroup 2 herein.

4.5 Methods of inspection. Methods of inspection shall be as specified in appropriate tables and as follows.

4.5.1 Pulse measurements. Conditions for pulse measurements shall be as specified in section 4 of MIL-STD-750.

MIL-PRF-19500/608C

TABLE I. Group A inspection. 1/ 2/

Inspection	MIL-STD-750		Symbol	Limit		Unit
	Method	Conditions		Min	Max	
<u>Subgroup 1</u>						
Visual and mechanical examination	2071					
<u>Subgroup 2</u> 3/						
Thermal impedance 1N6660CAT1, 1N6660DT1 (die 1) 1N6660CCT1, 1N6660DT1 (die 2)	3101	See 4.3.2	$Z_{\theta JC}$			$^{\circ}C/W$
Forward voltage	4011	$I_F = 5$ A (pk) pulsed (see 4.5.1) $I_F = 15$ A (pk) pulsed (see 4.5.1) $I_F = 30$ A (pk) pulsed (see 4.5.1)	V_{F1} V_{F2} V_{F3}	0.55 0.75 1.0		V dc V dc V dc
Reverse current	4016	DC method, $V_R = 45$ V dc, pulsed (see 4.5.1)	I_{R1}		1.0	mA dc
<u>Subgroup 3</u>						
High temperature operation:		$T_A = +125^{\circ}C$				
Reverse current leakage	4016	DC method, $V_R = 45$ V dc, pulsed (see 4.5.1)	I_{R2}		40	mA dc
Low temperature operation:						
Forward voltage	4011	$T_A = -55^{\circ}C$ $I_F = 15$ A (pk) pulsed (see 4.5.1)	V_{F4}		0.8	V dc
<u>Subgroup 4</u>						
Junction capacitance	4001	$V_R = 5$ V dc; $f = 1$ MHz; $V_{SIG} = 50$ mV (p-p) (max)	C_J		2,000	pF
<u>Subgroup 6</u>						
Surge	4066	$I_{FSM} = 300$ A (pk), 8.3 ms; pulsed (see 4.5.1)				
Electrical measurements		See table I, subgroup 2 herein				
<u>Subgroup 7</u> 3/						
Dielectric withstanding voltage	1016	$V_R = 500$ V dc; all leads shorted; V as measured from leads to case	DWV		10	μA
Electrical measurements		See table I, subgroup 2 herein.				

1/ For sampling plan, see MIL-PRF-19500.

2/ Each individual diode.

3/ If thermal impedance performed in 100-percent screening, this test need not be performed in table I.

TABLE II. Groups A, B, C, and E electrical end-point and delta measurements. 1/ 2/ 3/ 4/ 5/

Step	Inspection	MIL-STD-750		Symbol	Limits		Unit
		Method	Conditions		Min	Max	
1.	Forward voltage	4011	$I_F = 15$ A (pk), pulsed (see 4.5.1)	V_{F2}		0.75	V dc
2.	Reverse current leakage	4016	$V_R = 45$ V dc, pulsed (see 4.5.1), dc method	I_{R1}		1.0	mA dc
3.	Forward voltage	4011	$I_F = 5$ A (pk), pulsed (see 4.5.1)	ΔV_{F1}	± 50 mV dc from initial reading.		
4.	Reverse current	4016	$V_R = 45$ V dc, pulsed (see 4.5.1), dc method	ΔI_{R1}	± 25 μ A dc or 100 percent from initial reading, whichever is greater.		
5.	Thermal impedance	3101	See 4.3.2	$Z_{\theta JC}$			$^{\circ}$ C/W
	1N6660CAT1, 1N6660DT1 (die 1) 1N6660CCT1, 1N6660DT1 (die 2)					2.5 1.55	

1/ Each individual diode.

2/ The electrical measurements for table E-VIa (JANS) of MIL-PRF-19500 are as follows:

- a. Subgroup 3, see table II herein, steps 1 and 2.
- b. Subgroup 4, see table II herein, steps 1, 2, 3, 4, and 5.
- c. Subgroup 5, see table II herein, steps 1, 2, 3, and 4.

3/ The electrical measurements for table E-VIb (JANTX and JANTXV) of MIL-PRF-19500 are as follows:

- a. Subgroup 2, see table II herein, steps 1 and 2.
- b. Subgroup 3, see table II herein, steps 1, 2, and 5.
- c. Subgroup 6, see table II herein, steps 1 and 2.

4/ The electrical measurements for table E-VII of MIL-PRF-19500 are as follows:

- a. Subgroups 2 and 3, see table II herein, steps 1 and 2.
- b. Subgroup 6, see table II herein, steps 1, 2, and 5.

5/ Devices which exceed the table I, limits for this test shall not be accepted.

MIL-PRF-19500/608C

* TABLE III. Group E inspection (all quality levels) for qualification and requalification only.

Inspection	MIL-STD-750		Qualification
	Method	Conditions	
<u>Subgroup 1</u>			n = 38, c = 0
Temperature cycling	1051	500 cycles	
Hermetic seal			
Electrical measurements	1071	See table II, steps 1, 2, and 5	
<u>Subgroup 2</u>			n = 38, c = 0
Steady-state blocking life	1048	t = 1,000 hours, T _C = +125°C; V _R = 36 V dc	
Electrical measurements		See table II, steps 1, 2, 3, and 4	
<u>Subgroup 3 1/</u>			n = 22, c = 0
Surge	4066	Condition A; T _A = +25°C; I _{FSM} = 300 A, 100 surges	
Electrical measurements		See table II, steps 1 and 2	
<u>Subgroup 4</u>			
Thermal impedance curves	3101	See MIL-PRF-19500	
<u>Subgroup 6</u>			n = 3, c = 0
ESD	1020		

1/ For each diode.

TEMPERATURE-CURRENT DERATING CURVE
 $T_C = 25^\circ\text{C}$ 1N6660CCT1, ENTIRE PACKAGE

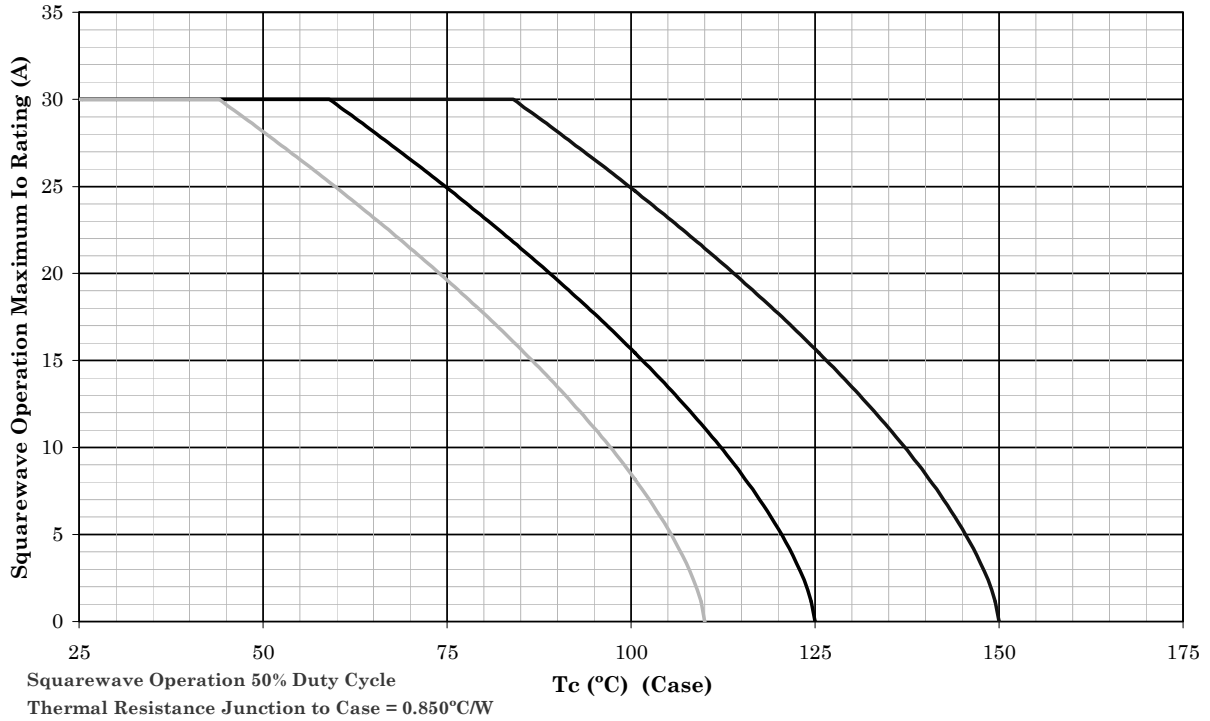

NOTES:

1. This is the true inverse of the worst case thermal resistance value. All devices are capable of operating at $\leq T_J$ specified on this curve. Any parallel line to this curve will intersect the appropriate current for the desired maximum T_J allowed.
2. Derate design curve constrained by the maximum junction temperature ($T_J \leq 150^\circ\text{C}$) and power rating specified. (See 1.3 herein.)
3. Derate design curves chosen at $T_J \leq 125^\circ\text{C}$, and 110°C to show current rating where most users want to limit T_J in their application.

FIGURE 2. Temperature-current derating graph.

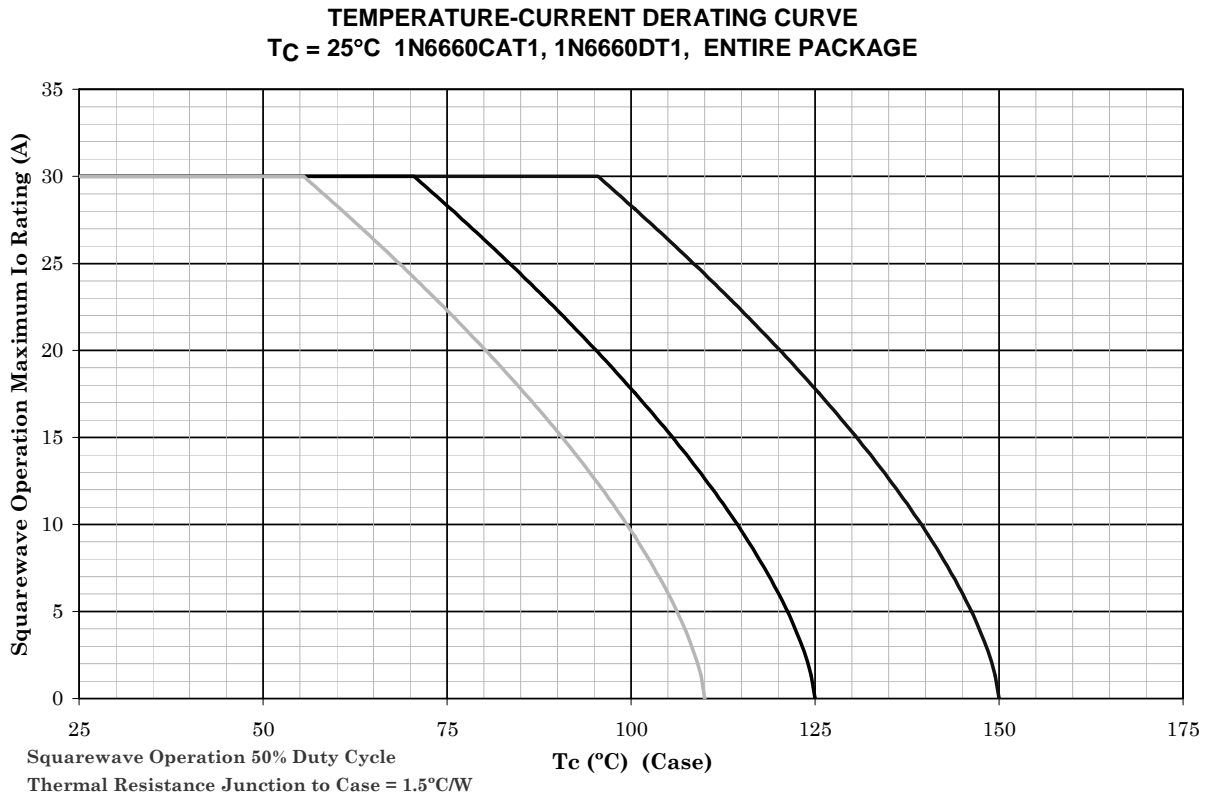

NOTES:

1. This is the true inverse of the worst case thermal resistance value. All devices are capable of operating at $\leq T_J$ specified on this curve. Any parallel line to this curve will intersect the appropriate current for the desired maximum T_J allowed.
2. Derate design curve constrained by the maximum junction temperature ($T_J \leq 150^\circ\text{C}$) and power rating specified. (See 1.3 herein.)
3. Derate design curves chosen at $T_J \leq 125^\circ\text{C}$, and 110°C to show current rating where most users want to limit T_J in their application.

FIGURE 3. Temperature-current derating graph 1N6660CAT1, 1N6660DT1, die 1.

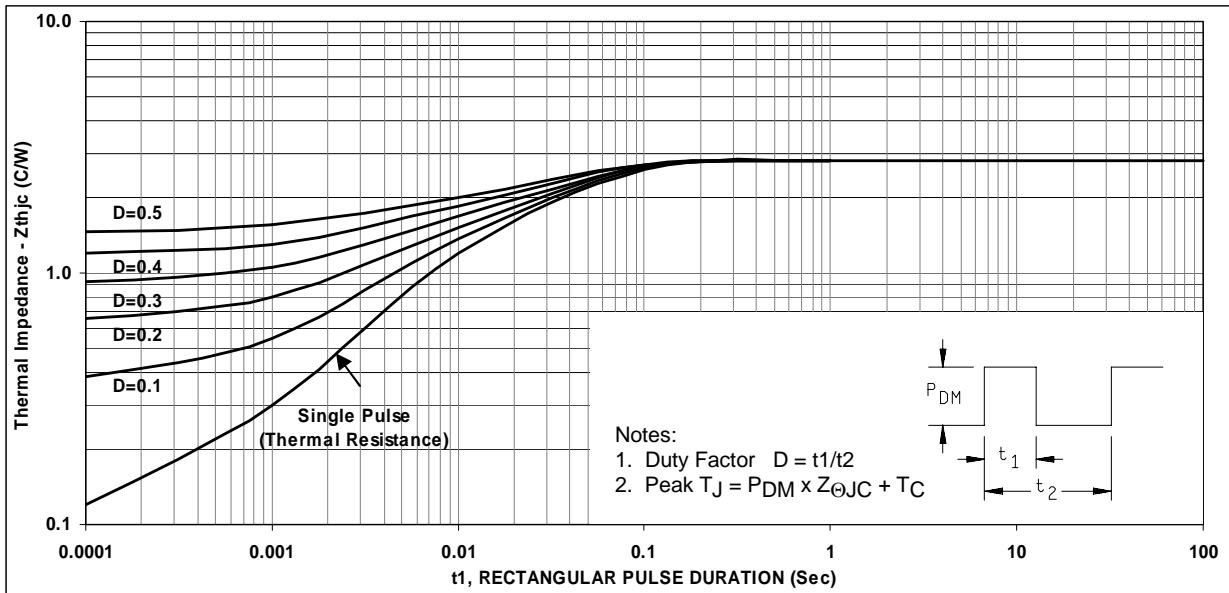

* FIGURE 4. Thermal impedance for each leg 1N6660CAT1, 1N6660DT1, die 1, and 1N6660R.

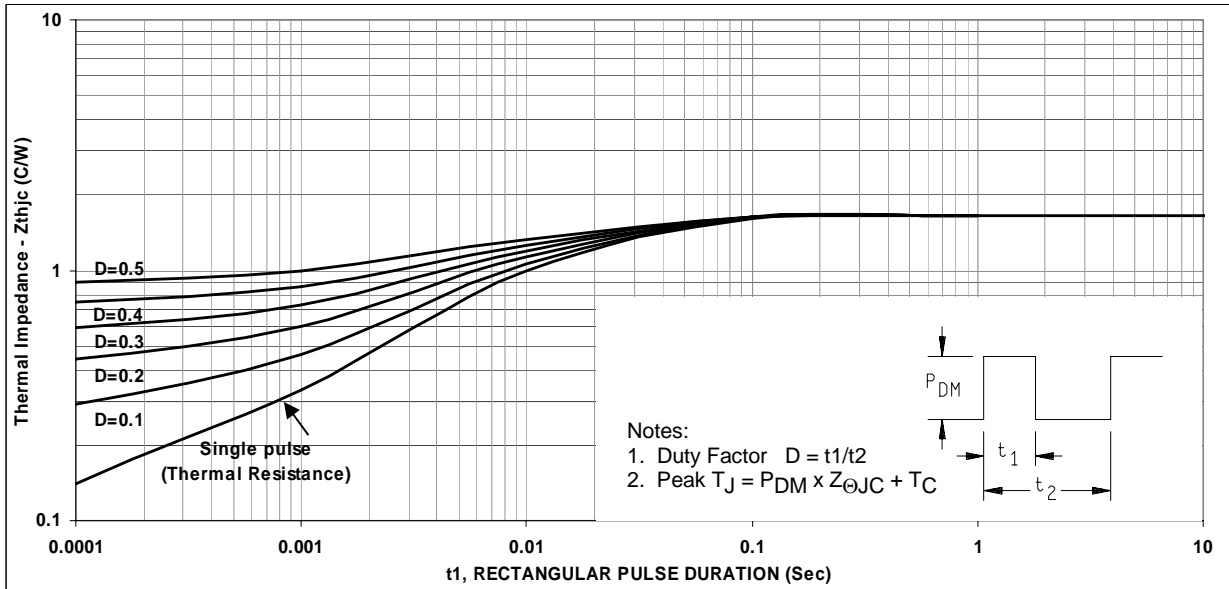

* FIGURE 5. Thermal impedance for each leg 1N6660CCT1, 1N6660DT1, die 2, and 1N6660.

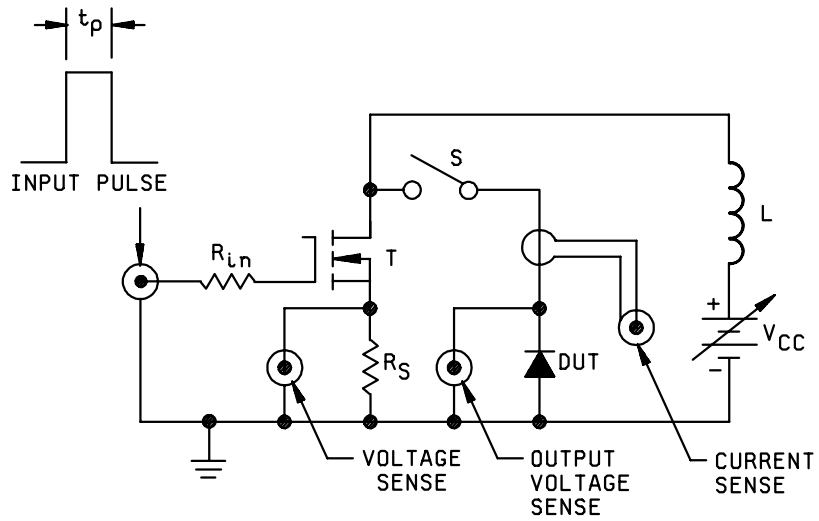

Input pulse: $R_{in} = 50$ ohms, 1 watt
 $V_G = 10$ volts, $R_S = 0.1$ ohms, 1 watt
 $Z_G = 50$ ohms, $V_{CC} \approx 10$ volts
 $t_p \approx 30$ ms, $L = 260$ μ H
 Duty cycle ≤ 1 percent, T = IRF130/2N6756 or equivalent

PROCEDURES:

1. With S open, adjust pulse width to test current of 2 amps through R_S .
2. Close S, verify test current with current sense.
3. Read peak output voltage (see 4.3.3).

FIGURE 6. Peak reverse energy test circuit.

5. PACKAGING

5.1 Packaging. For acquisition purposes, the packaging requirements shall be as specified in the contract or order (see 6.2). When packaging of materiel is to be performed by DoD or in-house contractor personnel, these personnel need to contact the responsible packaging activity to ascertain packaging requirements. Packaging requirements are maintained by the Inventory Control Point's packaging activities within the Military Service or Defense Agency, or within the Military Service's system commands. Packaging data retrieval is available from the managing Military Department's or Defense Agency's automated packaging files, CD-ROM products, or by contacting the responsible packaging activity.

6. NOTES

* (This section contains information of a general or explanatory nature that may be helpful, but is not mandatory. The notes specified in MIL-PRF-19500 are applicable to this specification.)

* 6.1 Intended use. Semiconductors conforming to this specification are intended for original equipment design applications and logistic support of existing equipment.

6.2 Acquisition requirements. Acquisition documents should specify the following:

- a. Title, number, and date of this specification.
- b. Packaging requirements (see 5.1).
- c. Lead material, finish, and formation (see 3.4.1).
- d. Product assurance level and type designator.

6.3 Qualification. With respect to products requiring qualification, awards will be made only for products which are, at the time of award of contract, qualified for inclusion in Qualified Manufacturers List (QML-19500) whether or not such products have actually been so listed by that date. The attention of the contractors is called to these requirements, and manufacturers are urged to arrange to have the products that they propose to offer to the Federal Government tested for qualification in order that they may be eligible to be awarded contracts or orders for the products covered by this specification. Information pertaining to qualification of products may be obtained from Defense Supply Center, Columbus, ATTN: DSCC/VQE, P.O. Box 3990, Columbus, OH 43218-3990 or e-mail vqe.chief@dla.mil.

6.4 Cross reference substitution list. The 1N6660CCT1 and 1N6660CAT1 are directly substitutable for the 1N6660 and 1N6660R respectively, and are the preferred part numbers.

6.5 Changes from previous issue. The margins of this specification are marked with asterisks to indicate where changes from the previous issue were made. This was done as a convenience only and the Government assumes no liability whatsoever for any inaccuracies in these notations. Bidders and contractors are cautioned to evaluate the requirements of this document based on the entire content irrespective of the marginal notations and relationship to the last previous issue.

Custodians:

Army - CR
Navy - EC
Air Force - 11
NASA - NA
DLA - CC

Preparing activity:

DLA - CC

(Project 5961-2006-086)

Review activities:

Army - AR, MI, SM
Navy - AS, MC, OS
Air Force - 19, 99

NOTE: The activities listed above were interested in this document as of the date of this document. Since organizations and responsibilities can change, you should verify the currency of the information above using the ASSIST Online database at <http://assist.daps.dla.mil>.