

信昌電子陶瓷股份有限公司

Prosperity Dielectrics Co., Ltd.

No. 148, Chang-An Road, Sec 1, Lu-Tsu Shiang, Taoyuan, Taiwan, ROC.

Tel. : 886-3-3224471 Fax : 886-3-3212216

SPECIFICATION FOR APPROVAL

DATE:

CUSTOMER: _____ LIMITED COMPANY

PART NAME: Thick Film Lead Free Surge Chip Resistors

CUSTOMER'S DWG. NO. _____

CUSTOMER'S PART NO. _____

PDC PART NO. FNF Series Approved

DESCRIPTION. _____

RESULT \ ACTION	" √ "	CUSTOMER'S SIGNATURE	NOTE
FULL APPROVED			
CONDITIONAL APPROVED			
REJECTED			

OUR ACTION	SIGNATURE
PREPARED BY	<i>Angel Wu</i>
CHECKED BY	<i>James Tseng</i>
APPROVED BY	<i>Roger Hsu</i>

CUSTOMER SIGNATURE FOR ACCEPTANCE

Features

- Small size and lightweight with size range per int'l standard
- Highly stable in auto-placement surface mounting application
- Suitable for withstanding circuit for surge voltage
- RoHS compliant & Halogen Free

Applications

- CD-ROM
- Power supply
- Automotive industry
- Measurement instrument
- Medical or Military equipment
- Electronic watch and camera

Configuration

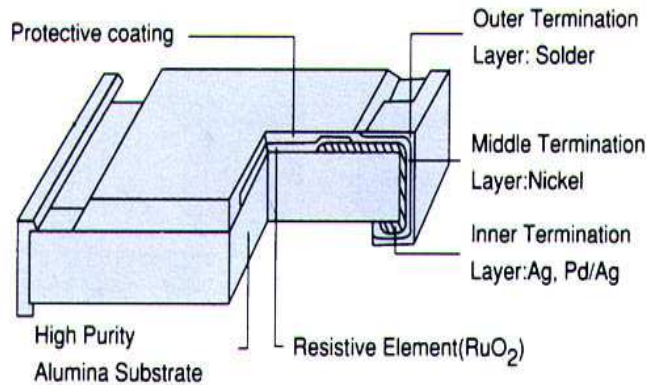

Dimensions

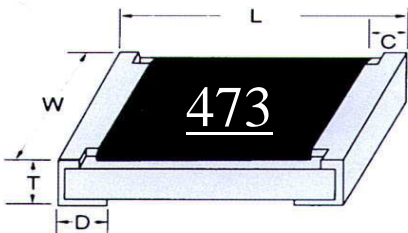

Size	L	W	C	D	T
0603	1.60±0.10	0.80±0.10	0.30±0.10	0.30±0.15	0.45±0.15
0805	2.00±0.10	1.25±0.10	0.40±0.20	0.40±0.20	0.50±0.15
1206	3.10±0.10	1.60±0.10	0.50±0.20	0.45±0.20	0.60±0.15
2010	5.00±0.20	2.50±0.20	0.65±0.25	0.60±0.25	0.55±0.10
2512	6.40±0.20	3.20±0.20	0.65±0.25	0.90±0.25	0.60±0.10

(unit: mm)

Power Derating Curve

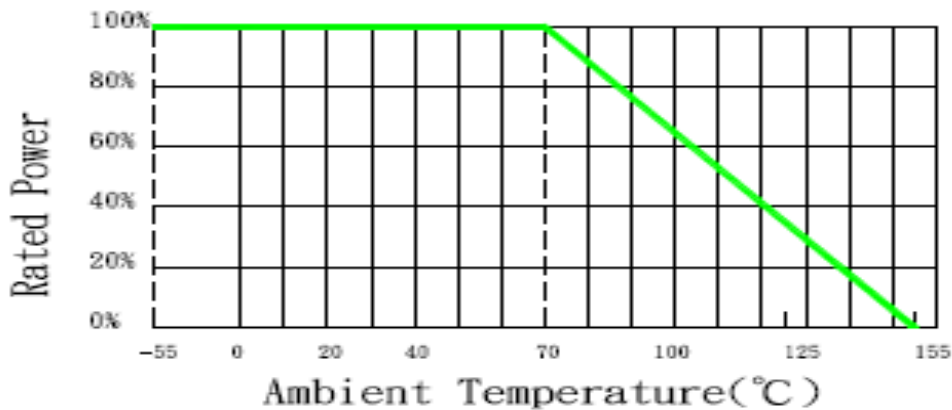

Rating

Type	Size	Power Rating at 70°C	Max. RCWV	Max. Overload Voltage	Resistance Tolerance (%)	Temperature Coefficient (TCR; ppm/°C)	Resistance Range		Standard Resistance Values
							Min.	Max.	
FNF03	0603	1/10W	50V	100V	±5%(J) ±10%(K) ±15%(L) ±20%(M)	±100	1Ω	1MΩ	E-24
FNF05	0805	1/8W	150V	300V					
FNF06	1206	1/4W	200V	400V					
FNF20	2010	1/2W	200V	400V					
FNF25	2512	1W	200V	400V					

Surge Performance
0603,0805,1206,2010,2512

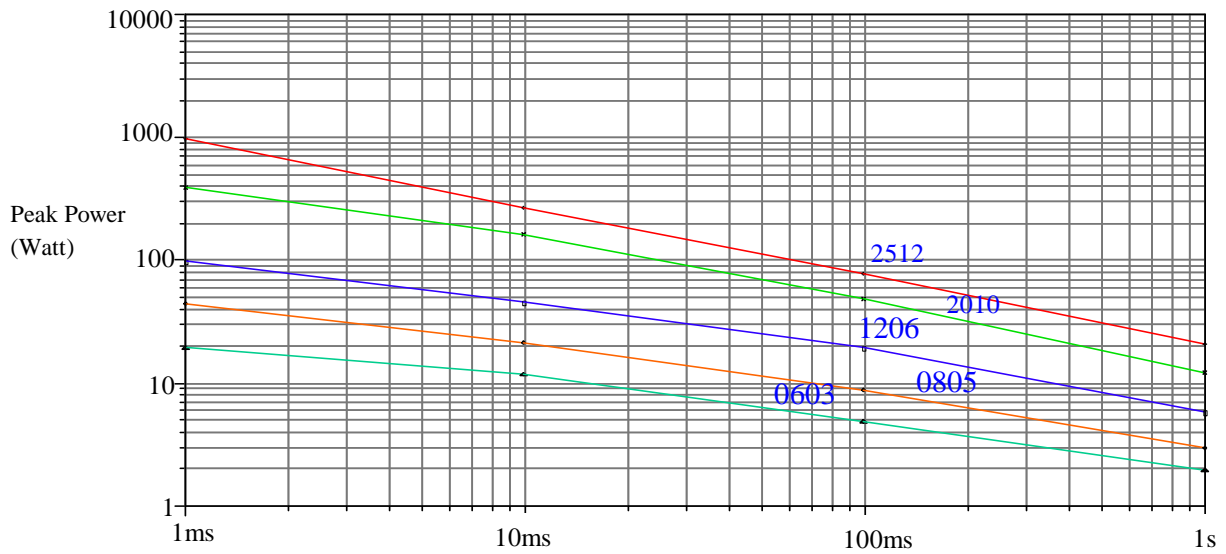

Surge duration

Part Number

FNF	05	K	T	-	473
Type	Size	Tolerance	Packing		GM
FNF	03 : 0603	J : ± 5%	T : Paper tape - 5Kpcs		
	05 : 0805	K : ± 10%	V : Paper tape - 10Kpcs		
	06 : 1206	L : ± 15%	W : Paper tape - 20Kpcs		
	20 : 2010	M : ± 20%	P : Plastic tape - 4Kpcs		
	25 : 2512		X : Plastic tape - 8Kpcs		
			Y : Plastic tape - 16Kpcs		
			B : Bulk Case		
			0805 - 10Kpcs		
			0603 - 25Kpcs		

Resistance Marking

• E - 24 SERIES



3 digit marking
Underline for identification surge resistors
examples: **473** $47 \times 10^3 = 47K\Omega$

SPECIFICATION

Tape And Reel Package

- Taping specs are according to EIA RS-481

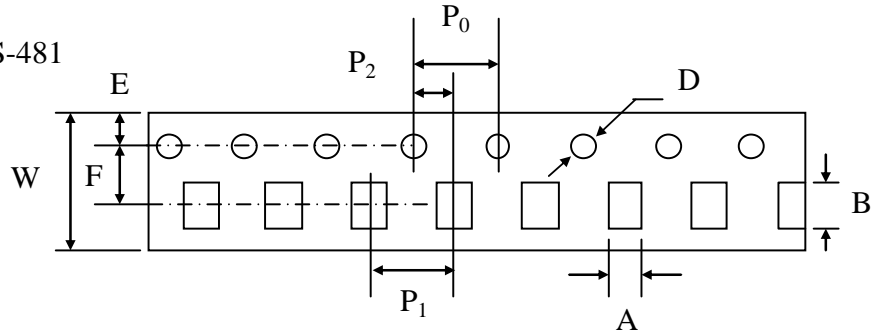

Accumulated dimensional tolerance $40 \pm 0.2 \text{ mm}$

Size	A	B	W	F	E	P1	P2	P0	D
0603	1.10 ± 0.20	1.90 ± 0.20	8.00 ± 0.30	3.50 ± 0.05	1.75 ± 0.10	4.00 ± 0.10	2.00 ± 0.05	4.00 ± 0.10	$1.50 \pm 0.10 / -0$
0805	1.65 ± 0.20	2.40 ± 0.20	8.00 ± 0.30	3.50 ± 0.05	1.75 ± 0.10	4.00 ± 0.10	2.00 ± 0.05	4.00 ± 0.10	$1.50 \pm 0.10 / -0$
1206	2.00 ± 0.20	3.60 ± 0.20	8.00 ± 0.30	3.50 ± 0.05	1.75 ± 0.10	4.00 ± 0.10	2.00 ± 0.05	4.00 ± 0.10	$1.50 \pm 0.10 / -0$
2010	2.80 ± 0.20	5.50 ± 0.20	12.00 ± 0.30	5.50 ± 0.05	1.75 ± 0.10	4.00 ± 0.10	2.00 ± 0.05	4.00 ± 0.10	$1.50 \pm 0.10 / -0$
2512	3.50 ± 0.20	6.70 ± 0.20	12.00 ± 0.30	5.50 ± 0.05	1.75 ± 0.10	4.00 ± 0.10	2.00 ± 0.05	4.00 ± 0.10	$1.50 \pm 0.10 / -0$

(unit: mm)

• Bulk Configuration

Size	Packaging Q'ty
0805	10Kpcs / Case
0603	25Kpcs / Case

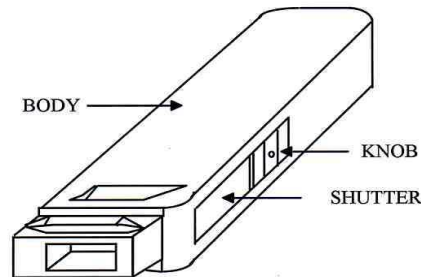

• Reel Package

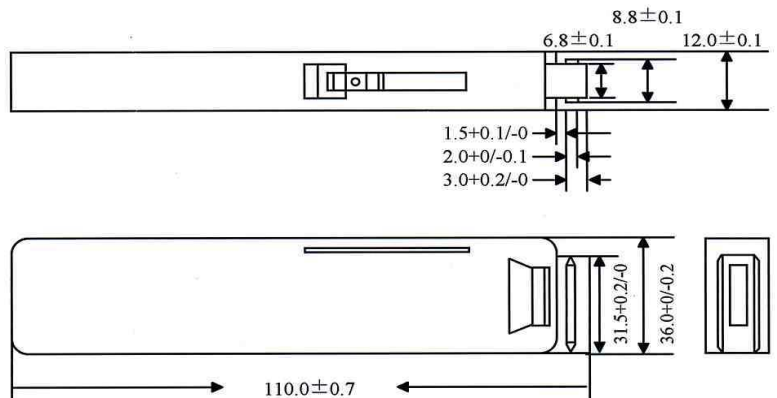
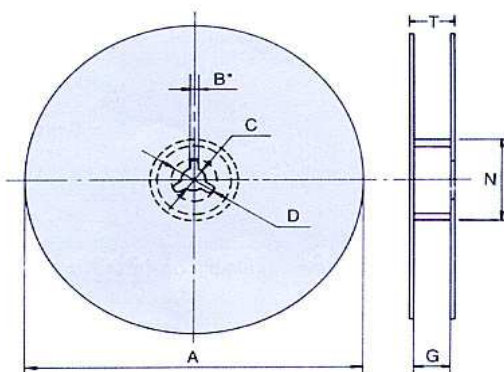

Size	Packaging Q'ty	A	N	C	D	B	G	T
0603	5Kpcs / Reel	178.0 ± 2.0	60.0 ± 0.5	13.0 ± 0.5	20min	2.0 ± 0.5	10.0 ± 1.5	14.9 max.
0805	10Kpcs / Reel	254.0 ± 2.0	100.0 ± 1.0	13.5 ± 0.5	20min	2.0 ± 0.5	10.0 ± 1.5	14.9 max.
1206	20Kpcs / Reel	330.0 ± 2.0	100.0 ± 1.0	13.5 ± 0.5	20min	2.0 ± 0.5	10.0 ± 1.5	14.9 max.
2010 2512	4Kpcs / Reel	178.0 ± 2.0	60.0 ± 0.5	13.0 ± 0.5	20min	2.0 ± 0.5	13.8 ± 1.5	16.7 max.
	8Kpcs / Reel	254.0 ± 2.0	100.0 ± 1.0	13.5 ± 0.5	20min	2.0 ± 0.5	13.8 ± 1.5	20.0 max.
	16Kpcs / Reel	330.0 ± 2.0	100.0 ± 1.0	13.5 ± 0.5	20min	2.0 ± 0.5	13.8 ± 1.5	20.0 max.

(unit: mm)

SPECIFICATION

■ Specification And Test Methods

ITEM	SPECIFICATION	TEST METHOD
DC Resistance	J : ±5% , K : ±10% , L : ±15% , M : ±20%	IEC 60115-1 / JIS C 5201-1, Clause 4.5 Measure the resistance value.
Short time Overload	$\Delta R \leq \pm (2\% + 0.1 \Omega)$	IEC 60115-1 / JIS C 5201-1, Clause 4.13 2.5×Rated voltage or Max. Overload Voltage for 5 sec. measure resistance after 30 minutes
Solderability	Over 95% of termination must be covered with solder	IEC 60115-1 / JIS C 5201-1, Clause 4.17 After immersing flux, dip in the 235±2°C molten solder bath for 2±0.5 sec.
Resistance to Solder Heat	$\Delta R \leq \pm (1\% + 0.1 \Omega)$ No mechanical damage	IEC 60115-1 / JIS C 5201-1, Clause 4.18 With 260±5°C for 10±1 sec.
Temperature Coefficient of Resistance (TCR)	±100 ppm/°C	IEC 60115-1 / JIS C 5201-1, Clause 4.8 Test temperature : 25°C (T1) → -55°C (T2) 25°C (T1) → +155°C (T2) $TCR (ppm/°C) = \frac{R2-R1}{R1} \times \frac{1}{T2-T1} \times 10^6$ T1: 25°C T2: Test temperature R1: Resistance at reference temperature (T1) R2: Resistance at test temperature (T2)
Load Life Humidity	$\Delta R \leq \pm (3\% + 0.1 \Omega)$	IEC 60115-1 / JIS C 5201-1, Clause 4.24 Maintain the temperature of the resistor at 40±2°C and 90~95% R.H. with the rated voltage applied. Cycle ON for 1.5 hours and OFF for 0.5 hour for 1000+48/-0 hours. After 1~4 hour, measure the resistance value.
Load Life	$\Delta R \leq \pm (3\% + 0.1 \Omega)$	IEC 60115-1 / JIS C 5201-1, Clause 4.25 Permanent resistance change after 1000+48/-0 hours (1.5 hours ON , 0.5 hour OFF) at RCWV or Max. Keep the resistor at 70±2°C ambient
Intermittent Overload	$\Delta R \leq \pm (5\% + 0.1 \Omega)$ No mechanical damage	JIS C 5202 5.8 4.0×Rated voltage (Max. Overload Voltage) 1 sec ON, 25 sec OFF, test 10,000 cycles
Temperature Cycle	$\Delta R \leq \pm (1\% + 0.1 \Omega)$ No mechanical damage	IEC 60115-1 / JIS C 5201-1, Clause 4.19 Repeat 5 cycles as follows -55°C (30 min.) + 25°C (2~3 min.) +155°C (30 min.) + 25°C (2~3 min.)
Insulation Resistance	Between termination and coating must be over 1000MΩ	IEC 60115-1 / JIS C 5201-1, Clause 4.6 Test voltage: 100±15V
Bending Strength	$\Delta R \leq \pm (1\% + 0.1 \Omega)$ No mechanical damage	IEC 60115-1 / JIS C 5201-1 Clause 4.33 Resistance change after bended on the 90mm PCB. Bend: 3mm for 0603、0805, 2mm for 1206, 2010, 2512

All product specification and data are subject to change without notice