

## LOW DROPOUT POSITIVE VOLTAGE REGULATOR

### FEATURES

- Very Low Dropout Voltage .... 120mV typ at 100mA  
380mV typ at 200mA
- High Output Current ..... 250mA ( $V_{OUT} = 5.0V$ )
- High Accuracy Output Voltage .....  $\pm 2\%$   
( $\pm 1\%$  Semicustom Version)
- Wide Output Voltage Range ..... 1.1V-6.0V
- Low Power Consumption ..... 1.1 $\mu$ A (Typ.)
- Low Temperature Drift .....  $\pm 100$ ppm/ $^{\circ}$ C Typ
- Excellent Line Regulation ..... 0.2%/V Typ
- Package Options ..... SOT-23A-3  
SOT-89-3  
TO-92
  
- Short Circuit Protected
- Custom Voltages Available from 1.1V to 6.0V in 0.1V Steps for a 2%, and 2.0V to 6.0V for a 1% Tolerance

### APPLICATIONS

- Battery-Powered Devices
- Cameras and Portable Video Equipment
- Pagers and Cellular Phones
- Solar-Powered Instruments
- Consumer Products

### FUNCTIONAL BLOCK DIAGRAM

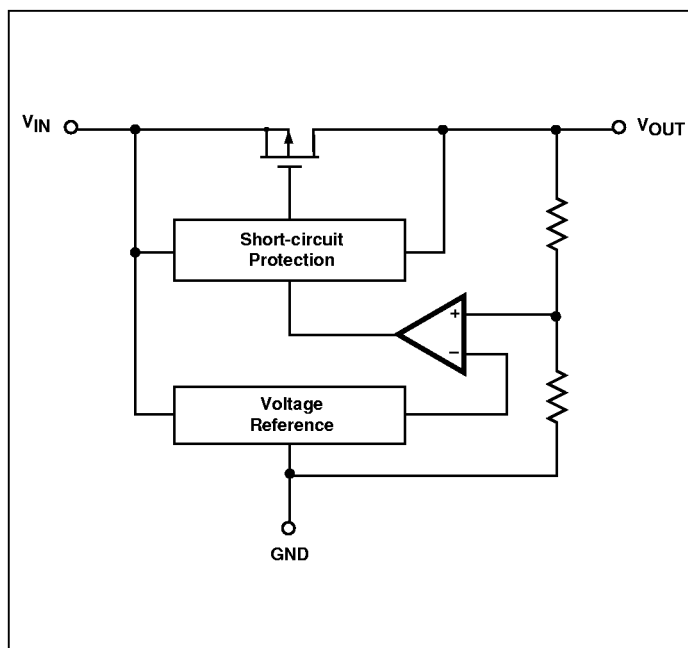

### GENERAL DESCRIPTION

The TC55 Series is a collection of CMOS low dropout positive voltage regulators which can source up to 250mA of current with an extremely low input-output voltage differential of 380mV.

The low dropout voltage combined with the low current consumption of only 1.1 $\mu$ A makes this part ideal for battery operation. The low voltage differential (dropout voltage) extends battery operating lifetime. It also permits high currents in small packages when operated with minimum  $V_{IN} - V_{OUT}$  differentials.

The circuit also incorporates short-circuit protection to ensure maximum reliability.

### PIN CONFIGURATIONS

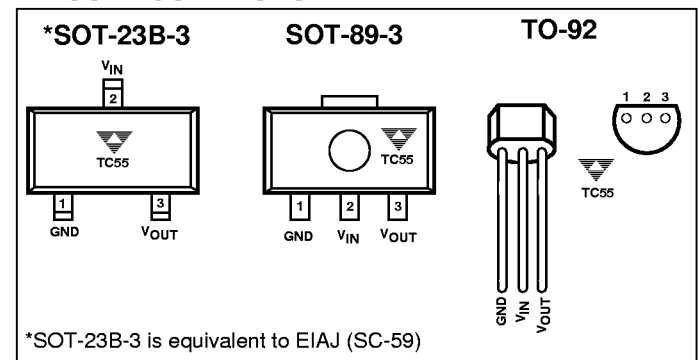

### ORDERING INFORMATION

**PART CODE** TC55 RP XX X X X XX XXX

**Output Voltage:** \_\_\_\_\_  
 Ex: 20 = 2.0V; 60 = 6.0V 1.0% Tol.  
 Ex: 11 = 1.1V; 60 = 6.0V 2.0% Tol.

**Extra Feature Code:** Fixed: 0

**Tolerance:** \_\_\_\_\_  
 1 = 1.0% (Custom)  
 2 = 2.0% (Standard)

**Temperature:** E: -40 $^{\circ}$ C to +85 $^{\circ}$ C

**Package Type and Pin Count:** \_\_\_\_\_  
 CB: SOT-23B-3 (equivalent to EIAJ (SC-59))  
 MB: SOT-89-3  
 ZB: TO-92-3

**Taping Direction:** \_\_\_\_\_  
 713: Standard Taping  
 723: Reverse Taping  
 No suffix: TO-92 Bulk

# LOW DROPOUT POSITIVE VOLTAGE REGULATOR

## TC55 Series

### ABSOLUTE MAXIMUM RATINGS\*

Item	Code	Ratings	Units
Input Voltage	$V_{IN}$	+12	V
Output Current	$I_{OUT}$	$Pd/(V_{IN} - V_{OUT})$	mA
Output Voltage	$V_{OUT}$	$(V_{SS} - 0.3)$ to $(V_{IN} + 0.3)$	V
Power Dissipation: ( $T_A \leq 70^\circ\text{C}$ )	SOT-23A-3 SOT-89 TO-92	Pd 240 400 440	mW
Operating Temperature Range	$T_A$	-40 to +85	$^\circ\text{C}$
Storage Temperature Range	$T_{stg}$	-65 to +150	$^\circ\text{C}$

### TC55RP50 ELECTRICAL CHARACTERISTICS: $V_{OUT(S)} = 5.0\text{V}$ , $T_A = 25^\circ\text{C}$ unless otherwise specified (see REMARKS).

Symbol	Parameter	Test Conditions	Min	Typ	Max	Unit
$V_{OUT(A)}$	Output Voltage	$I_{OUT} = 40\text{mA}$ $V_{IN} = 6.0\text{V}$	— 4.90	— 5.0	— 5.10	V
$I_{OUTmax}$	Maximum Output Current	$V_{IN} = 6.0\text{V}$ , $V_{OUT(A)} \geq 4.5\text{V}$	250	—	—	mA
$\Delta V_{OUT}$	Load Regulation	$V_{IN} = 6.0\text{V}$ , $1\text{mA} \leq I_{OUT} \leq 100\text{mA}$	—	40	80	mV
$V_{dif}$	I/O Voltage Difference	$I_{OUT} = 100\text{mA}$ $I_{OUT} = 200\text{mA}$	— —	120 380	300 600	mV
$I_{SS}$	Current Consumption	$V_{IN} = 6.0\text{V}$	—	1.1	3.0	$\mu\text{A}$
$\frac{V_{OUT(A)} \cdot 100}{\Delta V_{IN} \cdot V_{OUT(S)}}$	Voltage Regulation	$I_{OUT} = 40\text{mA}$ $6.0\text{V} \leq V_{IN} \leq 10.0\text{V}$	—	0.2	0.3	%/V
$V_{IN}$	Input Voltage		—	—	10.0	V
$\frac{\Delta V_{OUT(A)} \cdot 10^6}{V_{OUT(S)} \cdot \Delta T_A}$	Temperature Coefficient of Output Voltage	$I_{OUT} = 40\text{mA}$ $-40^\circ\text{C} \leq T_A \leq 85^\circ\text{C}$	—	$\pm 100$	—	ppm/ $^\circ\text{C}$
	Long Term Stability	$T_A = 125^\circ\text{C}$ , 1000 Hours	—	0.5	—	%

#### REMARKS:

$V_{OUT(S)}$ : Preset value of Output voltage

$V_{OUT(A)}$ : Actual value of Output voltage

$V_{dif}$ : Definition of I/O voltage difference =  $\{V_{IN1} - V_{OUT(A)}\}$

$V_{OUT(A)}$ : Output Voltage when  $I_{OUT}$  is fixed and  $V_{IN} = V_{OUT(S)} + 1.0\text{V}$

$V_{IN1}$ : Input Voltage when the output voltage is 98%  $V_{OUT(A)}$

### TC55RP40 ELECTRICAL CHARACTERISTICS: $V_{OUT(S)} = 5.0\text{V}$ , $T_A = 25^\circ\text{C}$ unless otherwise specified (see REMARKS).

Symbol	Parameter	Test Conditions	Min	Typ	Max	Unit
$V_{OUT(A)}$	Output Voltage	$I_{OUT} = 40\text{mA}$ $V_{IN} = 5.0\text{V}$	— 3.92	— 4.0	— 4.08	V
$I_{OUTmax}$	Maximum Output Current	$V_{IN} = 5.0\text{V}$ , $V_{OUT(A)} \geq 3.6\text{V}$	200	—	—	mA
$\Delta V_{OUT}$	Load Regulation	$V_{IN} = 5.0\text{V}$ , $1\text{mA} \leq I_{OUT} \leq 100\text{mA}$	—	45	90	mV
$V_{dif}$	I/O Voltage Difference	$I_{OUT} = 100\text{mA}$ $I_{OUT} = 200\text{mA}$	— —	170 400	330 630	mV
$I_{SS}$	Current Consumption	$V_{IN} = 5.0\text{V}$	—	1.0	2.9	$\mu\text{A}$
$\frac{\Delta V_{OUT(A)} \cdot 100}{\Delta V_{IN} \cdot V_{OUT(S)}}$	Voltage Regulation	$I_{OUT} = 40\text{mA}$ $5.0\text{V} \leq V_{IN} \leq 10.0\text{V}$	—	0.2	0.3	%/V
$V_{IN}$	Input Voltage		—	—	10.0	V
$\frac{\Delta V_{OUT(A)}}{V_{OUT(S)} \cdot \Delta T_A}$	Temperature Coefficient of Output Voltage	$I_{OUT} = 40\text{mA}$ $-40^\circ\text{C} \leq T_A \leq 85^\circ\text{C}$	—	$\pm 100$	—	ppm/ $^\circ\text{C}$
	Long Term Stability	$T_A = 125^\circ\text{C}$ , 1000 Hours	—	0.5	—	%

# LOW DROPOUT POSITIVE VOLTAGE REGULATOR

TC55 Series

## TC55RP30 ELECTRICAL CHARACTERISTICS: $V_{OUT}(S) = 5.0V$ , $T_A = 25^\circ C$ unless otherwise specified (see REMARKS).

Symbol	Parameter	Test Conditions	Min	Typ	Max	Unit
$V_{OUT}(A)$	Output Voltage	$I_{OUT} = 40mA$ $V_{IN} = 4.0V$	— 2.94	— 3.0	— 3.06	V
$I_{OUTmax}$	Maximum Output Current	$V_{IN} = 4.0V$ , $V_{OUT}(A) \geq 2.7V$	150	—	—	mA
$\Delta V_{OUT}$	Load Regulation	$V_{IN} = 4.0V$ , $1 mA \leq I_{OUT} \leq 80mA$	—	45	90	mV
$V_{dif}$	I/O Voltage Difference	$I_{OUT} = 80mA$ $I_{OUT} = 160mA$	— —	180 400	360 700	mV
$I_{SS}$	Current Consumption	$V_{IN} = 4.0V$	—	0.9	2.8	$\mu A$
$\frac{V_{OUT}(A) \cdot 100}{\Delta V_{IN} \cdot V_{OUT}(S)}$	Voltage Regulation	$I_{OUT} = 40mA$ $4.0V \leq V_{IN} \leq 10.0V$	—	0.2	0.3	%/V
$V_{IN}$	Input Voltage		—	—	10.0	V
$\frac{\Delta V_{OUT}(A) \cdot 10^6}{\Delta T_A \cdot V_{OUT}(S)}$	Temperature Coefficient of Output Voltage	$I_{OUT} = 40mA$ $-40^\circ C \leq T_A \leq 85^\circ C$	—	$\pm 100$	—	ppm/ $^\circ C$
	Long Term Stability	$T_A = 125^\circ C$ , 1000 Hours	—	0.5	—	%

\*Static-sensitive device. Unused devices must be stored in conductive material. Protect devices from static discharge and static fields. Stresses above those listed under Absolute Maximum Ratings may cause permanent damage to the device. These are stress ratings only and functional operation of the device at these or any other conditions above those indicated in the operational sections of the specifications is not implied. Exposure to Absolute Maximum Rating Conditions for extended periods may affect device reliability.

### MARKING

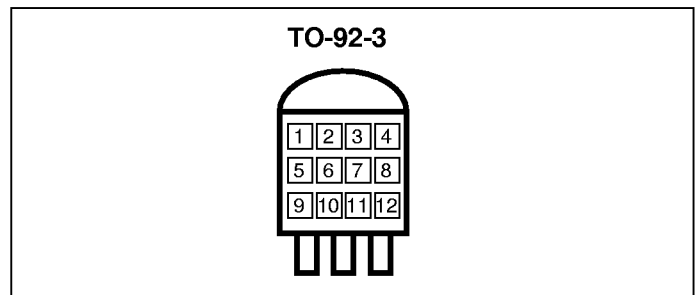
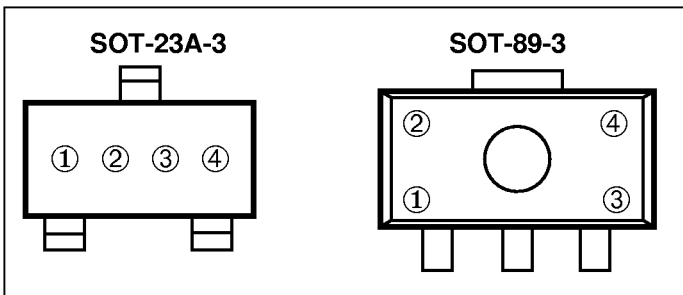

① represents first voltage digit

2 3 4 5 6  
ex: 3.xv = ③①①①①

② represents first decimal place voltage (x.0 - x.9)

A = x.0      E = x.4      L = x.8  
B = x.1      F = x.5      M = x.9  
C = x.2      H = x.6  
D = x.3      K = x.7  
ex: 3.4V = ③②E①①①

③ represents Polarity  
0 = Positive (fixed)

④ represents assembly lot number

①, ②, ③ & ④ = 55RP (fixed)

⑤ = first voltage digit (2-6)

⑥ = first voltage decimal (0-9)

⑦ = extra feature code : fixed : 0

⑧ = regulation accuracy  
1 =  $\pm 1.0\%$  (custom), 2 =  $\pm 2.0\%$  (standard)

⑨, ⑩, ⑪ & ⑫ = assembly lot number

# LOW DROPOUT POSITIVE VOLTAGE REGULATOR

## TC55 Series

### TAPING FORMS

#### Component Taping Orientation for 3L SOT-89

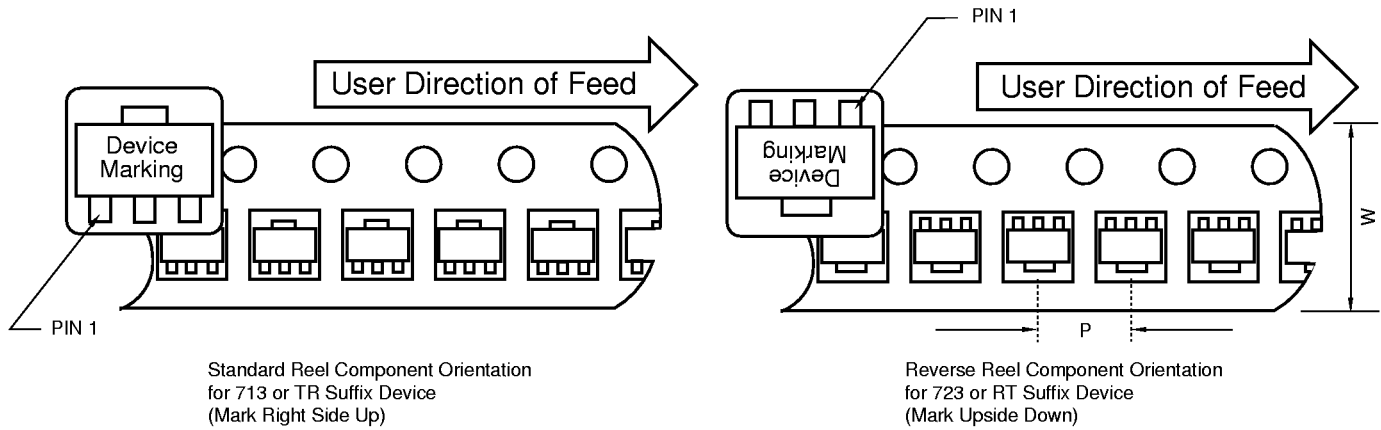

#### Component Taping Orientation for 3L SOT-23B (JEDEC TO-236) Devices

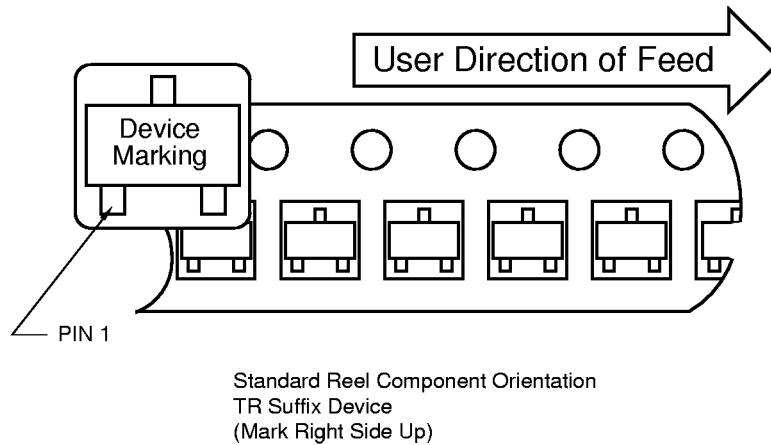

**Tape & Reel Specifications Table**

Package	Carrier Width (W)	Pitch (P)	Part Per Full Reel	Reel Size
3L SOT-23B	8 mm	4 mm	3000	7
3L SOT-89	8 mm	8 mm	1000	7

# LOW DROPOUT POSITIVE VOLTAGE REGULATOR

TC55 Series

## TAPING FORMS (Cont.)

### Component Taping Orientation for TO-92

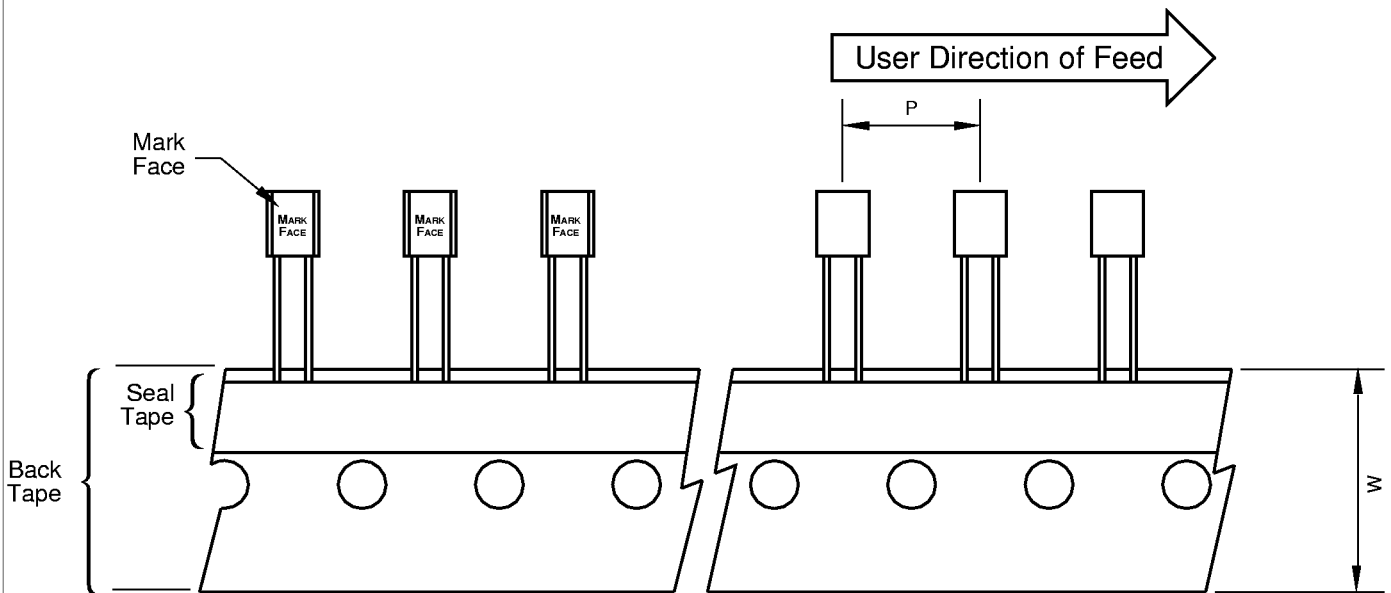
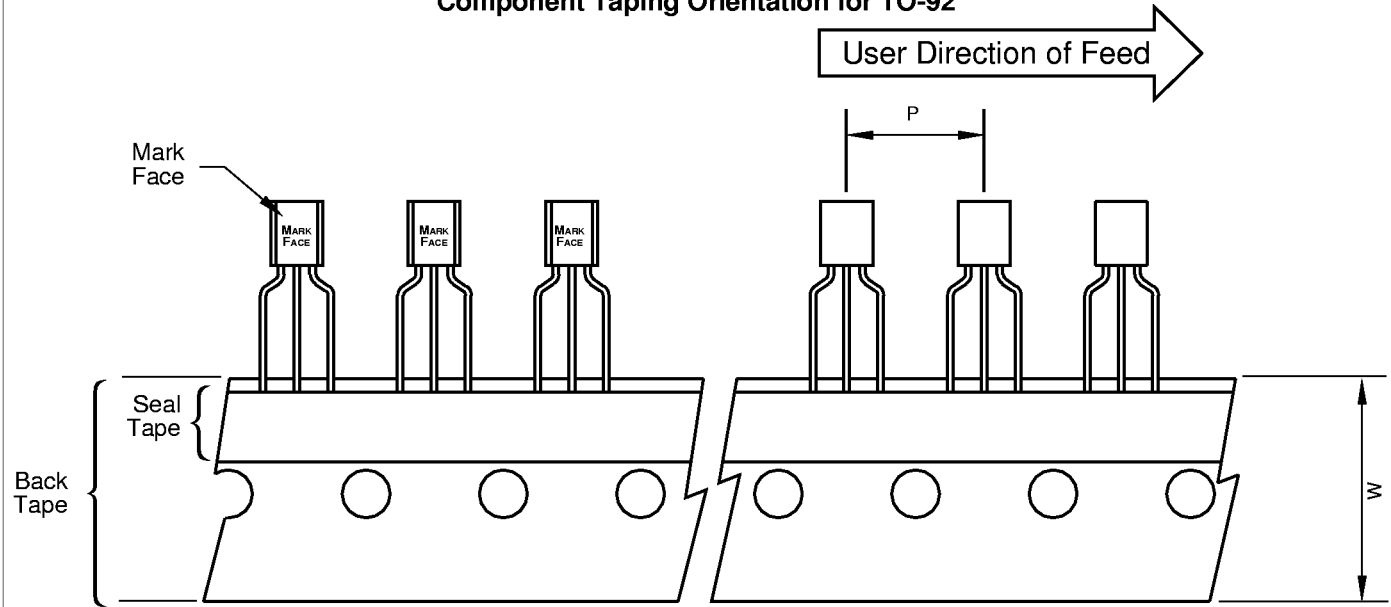

Standard Reel Component Orientation  
for 713 or TR Suffix Device

Reverse Reel Component Orientation  
for 723 or RT Suffix Device

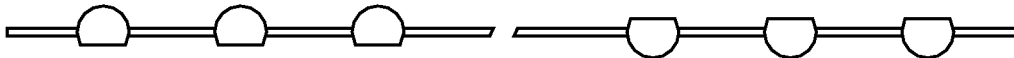

### Tape & Reel Specifications Table

Package	Carrier Width (W)	Pitch (P)	Part Per Full Reel	Reel Size
TO-92	18 mm	12.7 mm	1000/2000	13

# LOW DROPOUT POSITIVE VOLTAGE REGULATOR

## TC55 Series

### PACKAGE DIMENSIONS

#### \*SOT-23B-3

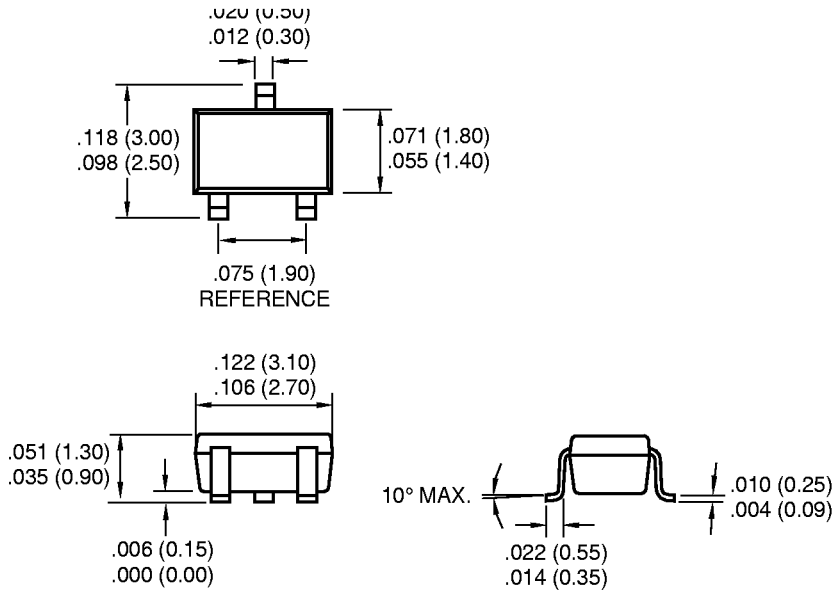

\*NOTE: SOT-23B-3 is equivalent to EIAJ (SC-59)

#### SOT-89-3

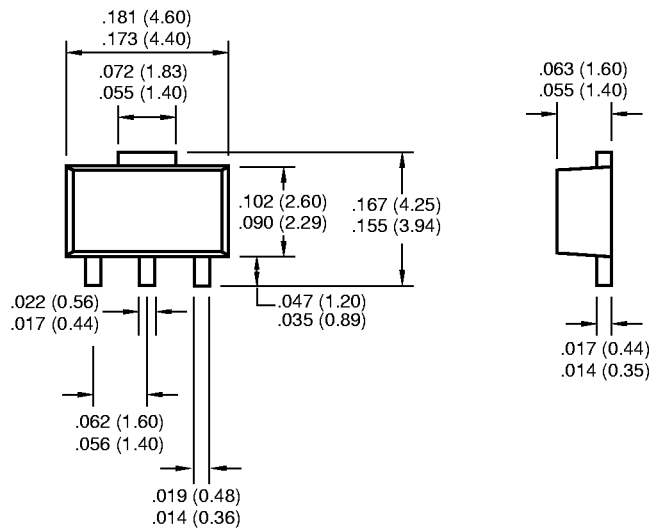

Dimensions: inches (mm)

# LOW DROPOUT POSITIVE VOLTAGE REGULATOR

TC55 Series

## PACKAGE DIMENSIONS (Cont.)

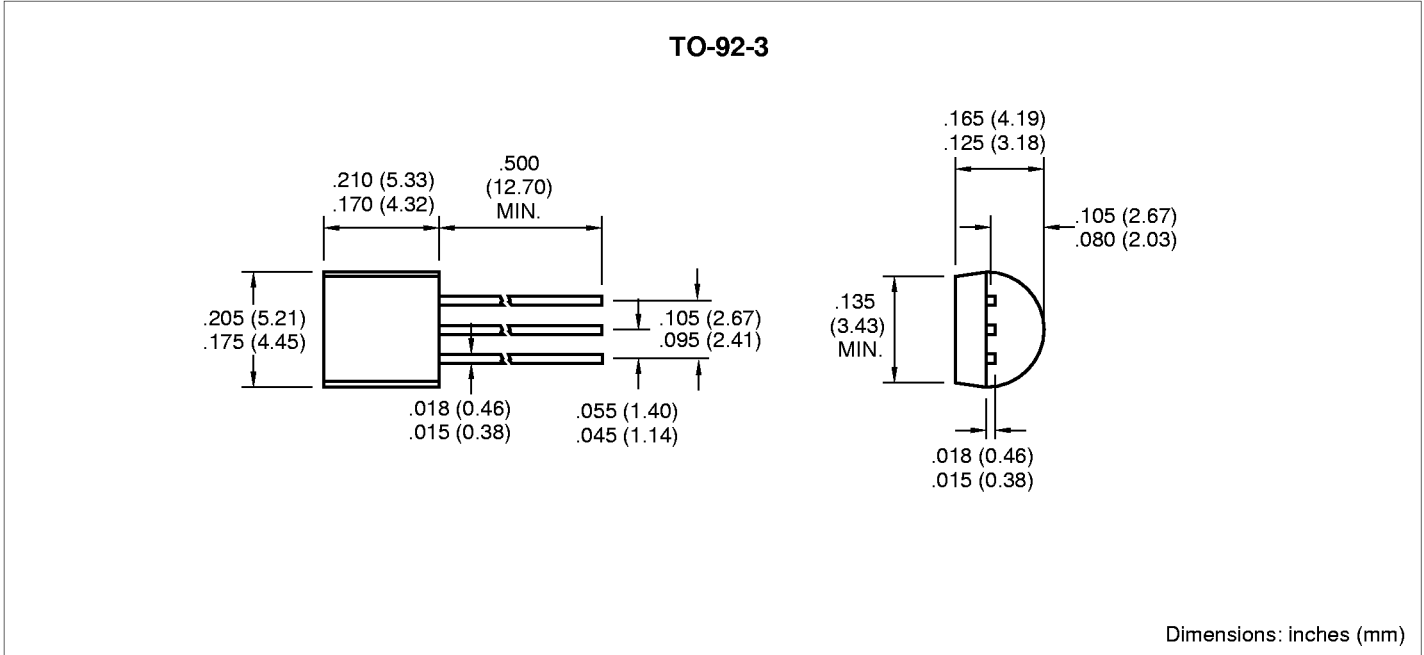

## Sales Offices

**TelCom Semiconductor, Inc.**  
1300 Terra Bella Avenue  
P.O. Box 7267  
Mountain View, CA 94039-7267  
TEL: 650-968-9241  
FAX: 650-967-1590  
E-Mail: liter@telcom-semi.com

**TelCom Semiconductor, Inc.**  
Austin Product Center  
8303 MoPac Expressway North  
Suite A-201  
Austin, TX 78759  
TEL: 512-345-2030  
FAX: 512-345-6085

**TelCom Semiconductor H.K. Ltd.**  
10 Sam Chuk Street, Ground Floor  
San Po Kong, Kowloon  
Hong Kong  
TEL: 852-2324-0122  
FAX: 852-2354-9957