

GAL16V8 Generic Array Logic

General Description

The NSC E²CMOS™ GAL® device combines a high performance CMOS process with electrically erasable floating gate technology. This programmable memory technology applied to array logic provides designers with reconfigurable logic and bipolar performance at significantly reduced power levels.

The 20-pin GAL16V8 features 8 programmable Output Logic Macrocells (OLMCs) allowing each TRI-STATE® output to be configured by the user. Additionally, the GAL16V8 is capable of emulating, in a functional/fuse map/parametric compatible device, all common 20-pin PAL® device architectures.

Programming is accomplished using readily available hardware and software tools. NSC guarantees a minimum 100 erase/write cycles.

Unique test circuitry and reprogrammable cells allow complete AC, DC, cell and functionality testing during manufacture. Therefore, NSC guarantees 100% field programmability and functionality of the GAL devices. In addition, electronic signature is available to provide positive device ID. A security circuit is built-in, providing proprietary designs with copy protection.

Features

- Electrically erasable cell technology
 - Reconfigurable logic
 - Reprogrammable cells
 - Guaranteed 100% yields
- High performance E²CMOS technology
 - Low power: 45 mA/90 mA max active
 - High Speed: 20 ns–35 ns max access
- Eight output logic macrocells
 - Maximum flexibility for complex logic designs
 - Also emulates 20-pin PAL devices with full function/fuse map/parametric compatibility
- Preload and power-on reset of all registers
 - 100% functional testability
- Fully supported by National PLAN™ development software
- High speed programming algorithm
- Security cell prevents copying logic

PAL Replacement by Device Type

| "Small-PAL" Mode | | | | "Registered-PAL" Mode | | | "Medium-PAL" Mode |
|------------------|------|------|------|-----------------------|-------|-------|-------------------|
| 10L8 | 12L6 | 14L4 | 16L2 | 16R8 | 16R6 | 16R4 | 16L8 |
| 10H8 | 12H6 | 14H4 | 16H2 | 16RP8 | 16RP6 | 16RP4 | 16H8 |
| 10P8 | 12P6 | 14P4 | 16P2 | | | | 16P8 |

PAL Replacement by Speed/Power

| PAL | | | GAL |
|---------|-------|--------|------------------------------------|
| Rev | Speed | Power* | Rev |
| B-2 | 25 ns | 90 mA | 25L or 20L or 25Q (45 mA) |
| A | 25 ns | 180 mA | 25L or 20L (90 mA) |
| B-2 MIL | 30 ns | 90 mA | 30L or 25L (110 mA) or 30Q (55 mA) |
| A MIL | 30 ns | 180 mA | 30L or 25L (110 mA) |
| B-4 | 35 ns | 45 mA | 30Q |
| A-2 | 35 ns | 90 mA | 30Q (45 mA) |
| STD | 35 ns | 180 mA | 25L (90 mA) |

*Shown for Medium PAL products

Block Diagram—GAL16V8

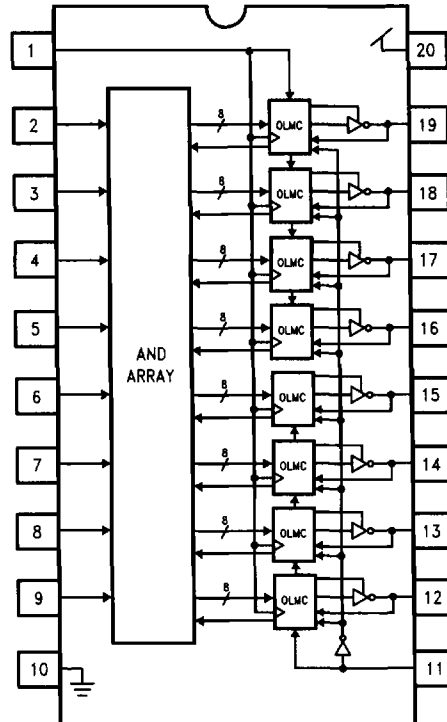

TL/L/9344-1

Absolute Maximum Ratings (Note 1)

If Military/Aerospace specified devices are required, please contact the National Semiconductor Sales Office/Distributors for availability and specifications.

| | |
|--|---------------------------------|
| Supply Voltage (V _{CC}) (Note 2) | -0.5V to +7.0V |
| Input Voltage (Note 2) | -2.5V to V _{CC} + 1.0V |
| Off-State Output Voltage (Note 2) | -2.5V to V _{CC} + 1.0V |
| Output Current | +100 mA |
| Storage Temperature | -65°C to +150°C |

| | |
|--|------------------|
| Ambient Temperature with Power Applied | -65°C to +125°C |
| Junction Temperature | -65°C to +150°C |
| Lead Temperature (Soldering, 10 seconds) | 260°C |
| ESD Tolerance | 500V |
| CZAP | = 100 pF |
| RZAP | = 150Ω |
| Test Method: | Human Body Model |
| Test Specification: | NSC SOP-5-028 |

Recommended Operating Conditions

SUPPLY VOLTAGE AND TEMPERATURE

| Symbol | Parameter | Commercial | | | Industrial | | | Military | | | Units |
|-----------------|--------------------------------|------------|-----|------|------------|-----|-----|----------|-----|-----|-------|
| | | Min | Nom | Max | Min | Nom | Max | Min | Nom | Max | |
| V _{CC} | Supply Voltage | 4.75 | 5 | 5.25 | 4.5 | 5 | 5.5 | 4.5 | 5 | 5.5 | V |
| T _A | Operating Free-Air Temperature | 0 | 25 | 75 | -40 | 25 | 85 | -55 | 25 | | °C |
| T _C | Operating Case Temperature | | | | | | | | | 125 | °C |

AC TIMING REQUIREMENTS

| Symbol | Parameter | GAL16V8-20L | | GAL16V8-25Q GAL16V8-25L | | GAL16V8-30Q GAL16V8-30L | | Units |
|--------------------|--|------------------|-----|----------------------------|-----|----------------------------|-----|-------|
| | | COM/IND | | COM/IND MIL* | | COM/IND* MIL | | |
| | | Min | Max | Min | Max | Min | Max | |
| t _{SU} | Set-Up Time (Input or Feedback before Clock) | 15 | | 20 | | 25 | | ns |
| t _H | Hold Time (Input after Clock) | 0 | | 0 | | 0 | | ns |
| t _W | Clock Pulse Width (High/Low) | 12 | | 15 | | 15 | | ns |
| t _{CYCLE} | Clock Cycle Period (with Feedback) (Note 3) | 30 | | 35 | | 45 | | ns |
| f _{CLK} | Clock Frequency (Note 4) | With Feedback | | 28.5 | | 22.2 | | MHz |
| | | Without Feedback | | 33.3 | | 33.3 | | |
| f _I | Input Frequency (Note 5) | 50.0 | | 40.0 | | 33.3 | | |
| t _{PR} | Clock Valid after Power-Up | 100 | | 100 | | 100 | | ns |

* -25Q available only in COM/IND operating ranges;
 -30L available only in MIL operating range (for COM/IND, use -25L or -30Q).

Note 1: Absolute maximum ratings are those values beyond which the device may be permanently damaged. Proper operation is not guaranteed outside the specified recommended operating conditions.

Note 2: Some device pins may be raised above these limits during programming and preload operations according to the applicable specification.

Note 3: t_{CYCLE} = t_{SU} + t_{CLK}

Note 4: f_{CLK} (with feedback) = (t_{CYCLE})⁻¹

f_{CLK} (without feedback) = (2 t_W)⁻¹

Note 5: f_I = (t_{PR})⁻¹

Electrical Characteristics Over Recommended Operating Conditions

| Symbol | Parameter | Conditions | Temperature Range | Min | Typ | Max | Units |
|------------|-------------------------------------|--|---|---------|-----|--------------|---------------|
| V_{IH} | High Level Input Voltage | | | 2.0 | | $V_{CC} + 1$ | V |
| V_{IL} | Low Level Input Voltage | | | -1.0 | | 0.8 | V |
| V_{OH} | High Level Output Voltage | $V_{CC} = \text{Min}$ | $I_{OH} = -3.2 \text{ mA}$ | COM/IND | 2.4 | | V |
| | | | $I_{OH} = -2.0 \text{ mA}$ | MIL | 2.4 | | V |
| V_{OL} | Low Level Output Voltage | $V_{CC} = \text{Min}$ | $I_{OL} = 24 \text{ mA}$ | COM/IND | | 0.5 | V |
| | | | $I_{OL} = 12 \text{ mA}$ | MIL | | 0.5 | V |
| I_{OZH} | High Level Off State Output Current | $V_{CC} = \text{Max}, V_O = V_{CC} (\text{Max})$ | | | | 10 | μA |
| I_{OZL} | Low Level Off State Output Current | $V_{CC} = \text{Max}, V_O = \text{GND}$ | | | | -10 | μA |
| I_I | Maximum Input Current | $V_{CC} = \text{Max}, V_I = V_{CC} (\text{Max})$ | | | | 10 | μA |
| I_{IH} | High Level Input Current | $V_{CC} = \text{Max}, V_I = V_{CC} (\text{Max})$ | | | | 10 | μA |
| I_{IL} | Low Level Input Current | $V_{CC} = \text{Max}, V_I = \text{GND}$ | | | | -10 | μA |
| I_{OS}^* | Output Short Circuit Current | $V_{CC} = 5.0\text{V}, V_O = \text{GND}$ | | -30 | | -130 | mA |
| I_{CC} | Supply Current | Quarter Power (GAL16V8-25Q, -30Q) | $f = 15 \text{ MHz}, V_{CC} = \text{Max}$ | COM | | 45 | mA |
| | | | | MIL/IND | | 55 | mA |
| | | Half Power (GAL16V8-20L, -25L, -30L) | $f = 15 \text{ MHz}, V_{CC} = \text{Max}$ | COM | | 90 | mA |
| | | | | MIL/IND | | 110 | mA |
| C_I | Input Capacitance | $V_{CC} = 5.0\text{V}, V_I = 2.0\text{V}$ | | | | 12 | pF |
| $C_{I/O}$ | I/O Capacitance | $V_{CC} = 5.0\text{V}, V_{I/O} = 2.0\text{V}$ | | | | 15 | pF |

*One output at a time for a maximum duration of one second @ 25°C.

Switching Characteristics Over Recommended Operating Conditions

| Symbol | Parameter | Conditions | GAL16V8-20L | | GAL16V8-25Q GAL16V8-25L | | GAL16V8-30Q GAL16V8-30L | | Units |
|-------------|---|--|-------------|-----|----------------------------|-----|----------------------------|-----|---------------|
| | | | COM/IND | | COM/IND MIL* | | COM/IND* MIL | | |
| | | | Min | Max | Min | Max | Min | Max | |
| t_{PD} | Input or Feedback to Combinatorial Output | S1 Closed, $C_L = 50 \text{ pF}$ | | 20 | | 25 | | 30 | ns |
| t_{CLK} | Clock to Registered Output or Feedback | S1 Closed, $C_L = 50 \text{ pF}$ | | 15 | | 15 | | 20 | ns |
| t_{PXG} | $\bar{G} \downarrow$ to Registered Output Enabled | Active High: S1 Open, $C_L = 50 \text{ pF}$ Active Low: S1 Closed, $C_L = 50 \text{ pF}$ | | 18 | | 20 | | 25 | ns |
| t_{PXZG} | $\bar{G} \uparrow$ to Registered Output Disabled | From V_{OH} : S1 Open, $C_L = 5 \text{ pF}$ From V_{OL} : S1 Closed, $C_L = 5 \text{ pF}$ | | 18 | | 20 | | 25 | ns |
| t_{PXI} | Input to Combinatorial Output Enabled via Product Term | Active High: S1 Open, $C_L = 50 \text{ pF}$ Active Low: S1 Closed, $C_L = 50 \text{ pF}$ | | 20 | | 25 | | 30 | ns |
| t_{PXZI} | Input to Combinatorial Output Disabled via Product Term | From V_{OH} : S1 Open, $C_L = 5 \text{ pF}$ From V_{OL} : S1 Closed, $C_L = 5 \text{ pF}$ | | 20 | | 25 | | 30 | ns |
| t_{RESET} | Power-Up to Registered Output High | S1 Closed, $C_L = 50 \text{ pF}$ | | 45 | | 45 | | 45 | μs |

* -25Q available only in COM/IND operating ranges;

-30L available only in MIL operating range (for COM/IND, use -25L or -30Q).

AC Test Load

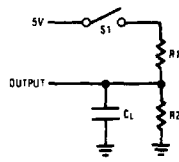

TL/L/9344-21

- MIL**
 R1 = 390
 R2 = 750
COM/IND
 R1 = 200
 R2 = 390

Test Waveforms

Setup and Hold

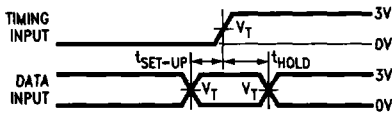

TL/L/9344-23

Pulse Width

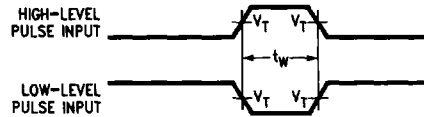

TL/L/9344-24

Propagation Delay

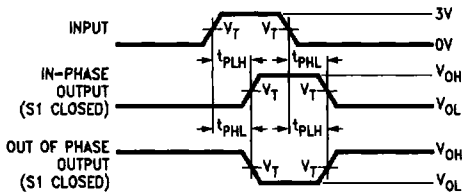

TL/L/9344-25

Enable and Disable

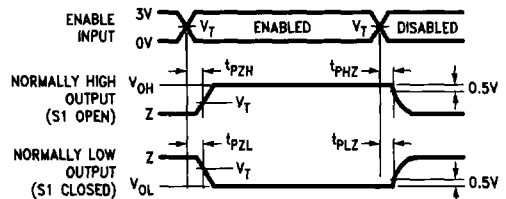

TL/L/9344-26

Notes:

C_L includes probe and jig capacitance.

V_T = 1.5V.

Test inputs have rise and fall times of 5 ns between 0.3V and 2.7V.

In the examples above, the phase relationships between inputs and outputs have been chosen arbitrarily.

Switching Waveforms

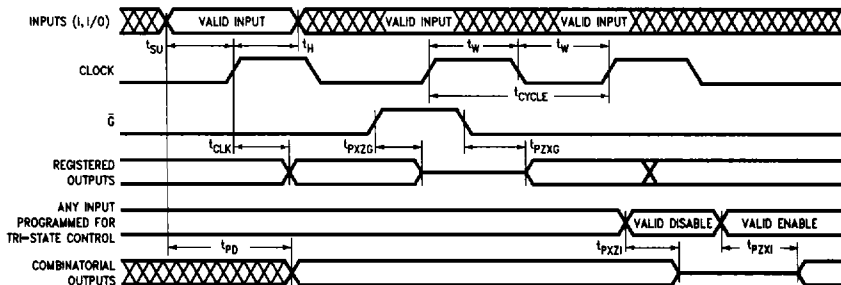

TL/L/8344-7

Power-Up Reset Waveforms

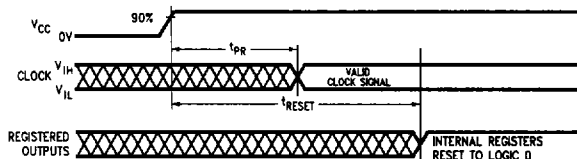

TL/L/8344-18

Input/Output Schematics

Input Translator/Buffer

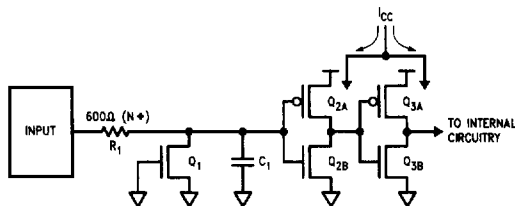

TL/L/8344-27

Phased Output Turn-On Circuit

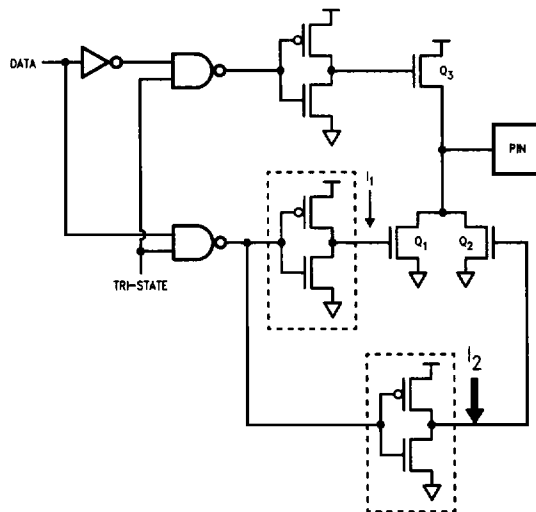

TL/L/8344-28

Ordering Information

Generic Array Logic Family
 Number of Array Inputs
 Output Type: V=Variable Architecture
 Number of Outputs
 Speed:

| t_{PD} (ns) | Power Versions | Temperature Ranges |
|---------------|----------------|--------------------|
| 20 | L | C, I, M |
| 25 | L, Q | C, I |
| 30 | L, Q | M |
| 35 | Q | C, I |

Power Version: Q=Quarter Power (45 mA)
 L=Half Power (90 mA)
 Package Type: N=20-Pin Plastic DIP
 J=20-Pin Ceramic DIP
 V=20-Lead Plastic Chip Carrier
 Temperature Range: C=Commercial (0°C to +75°C)
 I=Industrial (-40°C to +85°C)
 M=Military (-55°C to +125°C)

GAL 16 V 8 - 20 L N C

TL/L/9344-29

GAL16V8 Block Diagram—DIP Connections

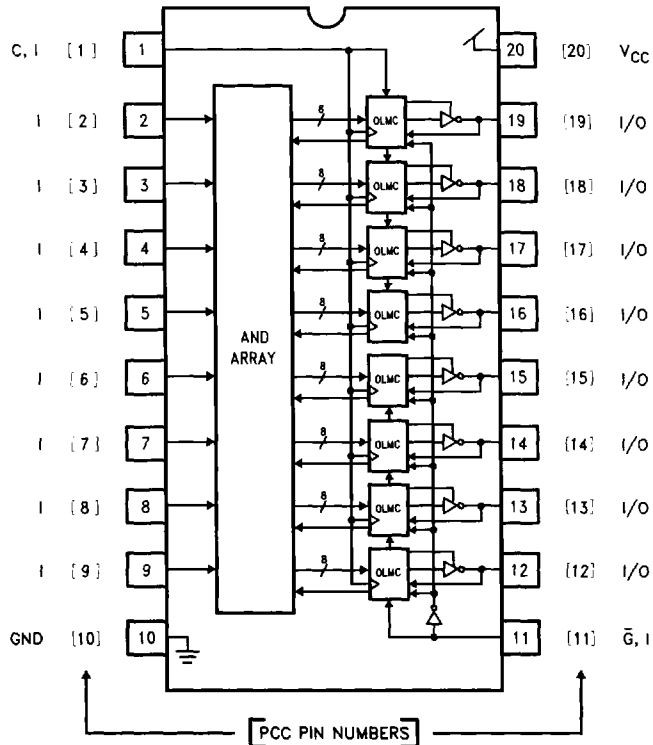

FIGURE 1

TL/L/9344-30

Functional Description

The GAL logic array consists of a programmable AND array with fixed OR-gate connections, similar to the bipolar PAL architecture. The logic array is organized as 16 complementary input lines crossing 64 "product term" lines with a programmable E²PROM cell at each intersection (2048 cells). Each programmable cell may establish a connection between an input line (true or complement phase of an array input signal) and a product term. A product term is satisfied (logically true) while all of the input lines "connected" to it are in the high logic state.

The 64 product terms are organized into eight output groups with eight terms each. Seven or eight of the product terms in each output group feed into an OR-gate to produce each output: logic function; one of the product terms may instead be used to control the associated TRI-STATE device output. The fundamental transfer function of each GAL output is the familiar Boolean sum-of-products. Design development software is available which accepts Boolean equations and converts them automatically into GAL programming patterns.

As shown in the GAL16V8 Block Diagram (Figure 1), a total of eight output logic functions are available. Each of the AND/OR logic functions feeds into an "output logic macrocell" (OLMC). The eight OLMCs control the flow of input and output signals between the logic array and the device's I/O pins.

Under control of an OLMC, each output may be designated either registered or combinatorial (non-registered). In the registered output configuration, the logic function output

passes through a D-type flip-flop triggered by the rising edge of the clock input. Additionally, the logic function's output polarity may be designated active-low or active-high (adjusted before the register, if present). OLMC options such as these are selected using a set of programmable architecture control cells. These architecture cells are normally configured automatically by the development software or programming hardware.

All of the possible I/O configurations of the GAL16V8 are classified into three basic modes: "Small-PAL" mode, "Registered-PAL" mode and "Medium-PAL" mode. These modes correspond to the architectures of the PAL families which the GAL16V8 can emulate. The modes determine the mixture of OLMC configurations which can be selected for the device. The OLMC Selection table (Table I) lists which functions can be selected on the device pin* 1 and pins* 11 through 19 for each of the three modes. The logic diagrams in Figure 3 illustrate these OLMC functions.

"OUTPUT" represents the always-active combinatorial output configuration available in the "Small-PAL" mode. "REGISTER" is the registered output with register feedback available in the "Registered-PAL" mode. "I/O" is the combinatorial bidirectional I/O available in "Registered-PAL" and "Medium-PAL" modes. "TRI-STATE" is the TRI-STATE combinatorial output function appearing on pins* 12 and 19 in the "Medium-PAL" mode. "INPUT" in Table I denotes an OLMC used as a dedicated input only.

*Applies to both 20-pin DIP and 20-lead PCC packages for GAL16V8.

20-Lead PCC Connection Diagram

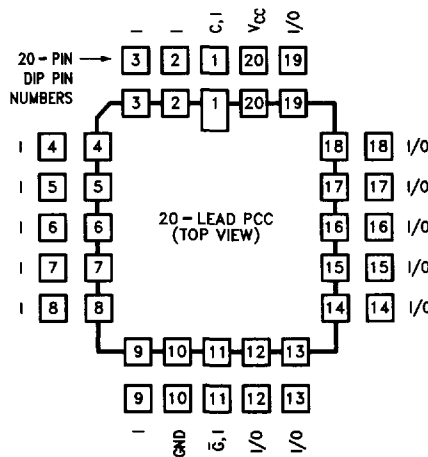
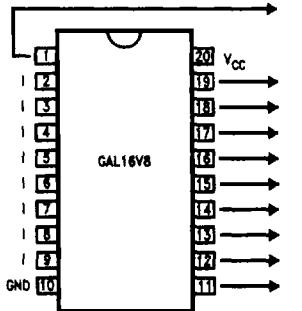

FIGURE 2

TL/L/8344-31

OLMC Selection Table



TL/L/8344-41

TABLE I

| "Small-PAL" Mode | "Registered-PAL" Mode | "Medium-PAL" Mode |
|------------------|-----------------------------|-------------------|
| INPUT | CLOCK | INPUT |
| INPUT or OUTPUT* | REGISTER or I/O | TRI-STATE** |
| INPUT or OUTPUT* | REGISTER or I/O | I/O |
| INPUT or OUTPUT* | REGISTER or I/O | I/O |
| OUTPUT* | REGISTER or I/O | I/O |
| OUTPUT* | REGISTER or I/O | I/O |
| INPUT or OUTPUT* | REGISTER or I/O | I/O |
| INPUT or OUTPUT* | REGISTER or I/O | I/O |
| INPUT or OUTPUT* | REGISTER or I/O | I/O |
| INPUT or OUTPUT* | REGISTER or I/O | TRI-STATE** |
| INPUT | OUTPUT ENABLE (\bar{G}) | INPUT |

*Active combinatorial output

**TRI-STATE combinatorial output

PAL Replacement Configurations

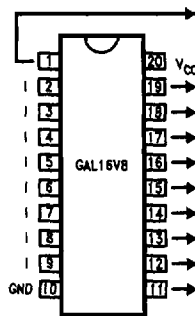

TL/L/8344-42

**EMULATED
PAL PRODUCTS**

TABLE II

| "Small PAL" Mode | | | | "Registered-PAL" | | | "Medium-PAL" |
|------------------|---------|---------|---------|------------------|-----------|-----------|--------------|
| INPUT | INPUT | INPUT | INPUT | CLOCK | CLOCK | CLOCK | INPUT |
| OUTPUT* | INPUT | INPUT | INPUT | REGISTER | I/O | I/O | TRI-STATE** |
| OUTPUT* | OUTPUT* | INPUT | INPUT | REGISTER | REGISTER | I/O | I/O |
| OUTPUT* | OUTPUT* | OUTPUT* | INPUT | REGISTER | REGISTER | REGISTER | I/O |
| OUTPUT* | OUTPUT* | OUTPUT* | OUTPUT* | REGISTER | REGISTER | REGISTER | I/O |
| OUTPUT* | OUTPUT* | OUTPUT* | OUTPUT* | REGISTER | REGISTER | REGISTER | I/O |
| OUTPUT* | OUTPUT* | OUTPUT* | INPUT | REGISTER | REGISTER | REGISTER | I/O |
| OUTPUT* | OUTPUT* | INPUT | INPUT | REGISTER | REGISTER | I/O | I/O |
| OUTPUT* | INPUT | INPUT | INPUT | REGISTER | I/O | I/O | TRI-STATE** |
| INPUT | INPUT | INPUT | INPUT | \bar{G} | \bar{G} | \bar{G} | INPUT |
| 10L8 | 12L6 | 14L4 | 16L2 | 16R8 | 16R6 | 16R4 | 16L8 |
| 10H8 | 12H6 | 14H4 | 16H2 | 16RP8 | 16RP6 | 16RP4 | 16H8 |
| 10P8 | 12P6 | 14P4 | 16P2 | | | | 16P8 |

*Active combinatorial output.

**TRI-STATE combinatorial output.

OLMC Configurations

OUTPUT (Active Combinatorial Output)

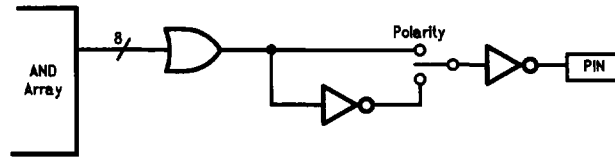

TL/L/9344-32

REGISTER (Registered Output)

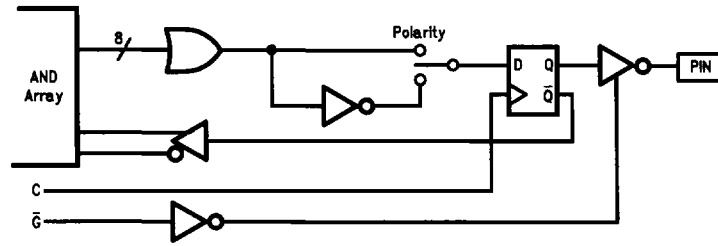

TL/L/9344-33

I/O (Combinatorial Input/Output)

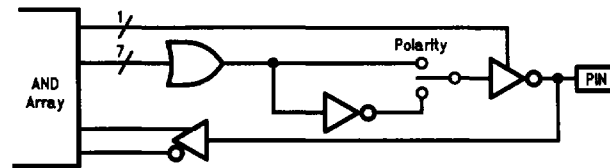

TL/L/9344-34

TRI-STATE (TRI-STATE Combinatorial Output)

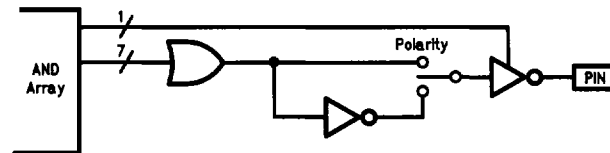

TL/L/9344-43

FIGURE 3

Functional Description (Continued)

In the "Small-PAL" and "Medium-PAL" modes (Table I), pins* 1 and 11 are always dedicated inputs. In the "Registered-PAL" mode, however, pin* 1 becomes the clock input controlling all OLMC registers, and pin* 11 becomes the output enable (\bar{G}) input controlling the TRI-STATE outputs of all registered OLMCs. Within the "Small-PAL" and "Registered-PAL" modes in Table I, the functions of pins* 12 through 19 can be selected individually from either of the two functions listed. For example, in "Registered-PAL" mode, pins* 12 through 19 can each be designated as either a registered output or a combinatorial I/O. The "Medium-PAL" mode represents a single fixed configuration used to emulate combinatorial medium PAL devices (16L8, 16H8, 16P8).

Table II lists the bipolar PAL products which the GAL16V8 can emulate, and the specific input/output configurations used. This is just a subset, however, of all the configurations provided in Table I.

All registers in a GAL device are reset to the low state upon power-up. The active-low outputs, in turn, assume high logic levels (if enabled) regardless of the selected output polarity. This may simplify sequential circuit design and test. To ensure successful power-up reset, V_{CC} must rise monotonically until the specified operating voltage is attained. During power-up, the clock input should assume a valid, stable logic state as early as possible (within the specified time, t_{PP}) to avoid interfering with the reset operation. The clock input should also remain stable until after the power-up reset operation is completed to allow the registers to capture the proper next state on the first high-going clock transition.

It should be noted that the switching of any input not logically connected to a product term or logic function has no effect on the associated output logic state. To minimize power consumption, however, unused inputs should be connected to a stable logic level such as ground or V_{CC} (CMOS GAL inputs may be tied directly to the supply voltage without causing excessive loading conditions).

*Applies to both 20-pin DIP and 20-lead PCC packages for GAL16V8.

Clock/Input Frequency Specifications

The clock frequency (f_{CLK}) parameter listed in the Recommended Operating Conditions table specifies the maximum speed at which the GAL registers are guaranteed to operate. Clock frequency is defined differently for the two cases in which register feedback is used versus when it is not. In a data-path type application, when the logic functions fed into the registers are not dependent on register feedback from the previous cycle (i.e. based only on external inputs), the minimum required cycle period (f_{CLK}^{-1} without feedback) is defined as the greater of the minimum clock period (t_w high + t_w low) and the minimum "data window" period ($t_{SU} + t_H$). This assumes optimal alignment between data inputs and the clock input. In sequential logic applications such as

state machines, the minimum required cycle period ($t_{CYCLE} = f_{CLK}^{-1}$ with feedback) is defined as $t_{CLK} + t_{SU}$. This provides sufficient time for outputs from the registers to feed back through the logic array and set up on the inputs to the registers before the end of each cycle.

The input frequency (f_i) parameter specifies the maximum rate at which each GAL input can be toggled and still produce valid logic transitions on each combinatorial output. The f_i specification is derived as the inverse of the combinatorial propagation delay (t_{PD}).

Design Development Support

A variety of software tools and programming equipment is available to support the development of designs using GAL products. Typical software packages accept Boolean logic equations to define desired functions. Most are available to run on personal computers and generate a JEDEC-compatible "cell-map" (analogous to a PAL "fuse-map"). The industry-standard JEDEC format ensures that the resulting cell-map file can be down-loaded into a variety of programming equipment. Many software packages and programming units support a large variety of programmable logic products as well. The PLAN™ software package from National Semiconductor supports all programmable logic products available from National and is fully JEDEC-compatible. PLAN software also provides automatic device selection based on the designer's Boolean logic equations.

National strongly recommends using only approved programming hardware and software for developing GAL designs. Programming using unapproved equipment generally voids all guarantees. Approved programmers incorporate specialized programming algorithms that program the array and automatically configure the architecture cells. To ensure data retention and reliability, the programming algorithm also tracks the number of programming cycles to which each GAL device has been subjected since shipment, and stores this information automatically in the device.

The special GAL programming algorithm can also program a GAL device using a standard fuse-map developed for any of the emulated PAL products. PAL fuse-maps can be created by any JEDEC-compatible PAL development software or by loading the fuse pattern from an existing programmed PAL device into the programming unit (provided the PAL device has not been secured). However, to utilize the full flexibility of the GAL architecture, true GAL development software (such as PLAN software) is recommended.

Detailed logic diagrams showing all JEDEC cell-map addresses in the GAL logic array and OLMC are provided for direct map editing and diagnostic purposes (see "Programming Details"). For a list of current software and programming support tools available for these devices, please contact your local National sales representative or distributor. If detailed specifications of the GAL programming algorithm are needed, please contact the National Semiconductor Programmable Device Support department.

Security Cell

A security cell is provided on all GAL16V8 devices as a deterrent to unauthorized copying of the array configuration patterns. Once programmed, the circuitry enabling array access is disabled, preventing further programming or verification of the array. The security cell can be erased only in conjunction with the array during a bulk erase cycle, so the original configuration can never be examined once this cell is programmed.

Electronic Signature

Each GAL device contains an electronic signature word consisting of 64 bits of reprogrammable memory. The electronic signature word can be programmed to contain any identification information desired by the user. Some uses include pattern identification labels, revision numbers, dates, inventory control information, etc. The data stored in the electronic signature word has no effect on the functionality of the device. The information is read out of the device using the normal program verification procedure provided by the programming equipment. The information may be accessed at any time independent of the state of the security cell. National's PLAN development software allows electronic signature data to be entered by the user and downloaded to the programming equipment.

Bulk Erase

The programming equipment automatically performs a bulk erase operation prior to each programming operation. No special erase operation need be performed by the user. Bulk erase clears the logic array, architecture cells, security cell, and electronic signature information. The GAL device is thereby reverted back to its virgin state.

Latch-Up Protection

GAL devices are designed with an on-chip charge pump to negatively bias the substrate. The negative bias is of sufficient magnitude to prevent input undershoots from causing the circuitry to latch. Additionally, outputs are designed with n-channel pullups instead of the traditional p-channel pullups to eliminate any possibility of SCR induced latching.

Manufacturer Testing

Because of E²CMOS technology, GAL devices can be reprogrammed in milliseconds. This allows each device to be completely tested by the manufacturer using numerous logic array and architecture patterns prior to shipping. Every programmable cell and every logic path through every device is fully tested for programmability, functionality and performance to all AC and DC parameters. The customer can therefore expect 100% programming and functional yield and 100% compliance of all GAL products to datasheet specifications.

The testing procedure performed on all GAL devices by the manufacturer tests all aspects of device operation. Extensive testing of all programmable cells in the device include margin testing, internal verify, and program retention during high-temperature bake. All DC and AC parameters are tested at hot and cold temperatures using a variety of worst

case logic and signal patterns. Functional tests include reprogramming each OLMC to all valid architectural configurations.

Register Preload

The register preload feature allows OLMC registers to be directly loaded with any desired data pattern. It also allows the present state of OLMC registers to be examined regardless of TRI-STATE control conditions. This simplifies testing of devices after programming. A device may be put into any desired register state at any point during the functional test sequence. The test sequence may then be resumed to verify proper next-state transitions. This allows complete verification of sequential logic circuits, including states that are normally impossible or difficult to reach. It may also shorten the overall test time significantly.

Register preload is not an operational mode and is not intended for board-level testing because elevated voltage levels must be applied to the device. The programming equipment normally provides the register preload capability as part of its functional test facility. Note that the testing of GAL devices after programming by the user may be considered unnecessary because all E²CMOS GAL products are completely tested by the manufacturer, guaranteeing 100% post-programming functional yield.

The register preload algorithm is described for those users who wish to test programmed GAL devices using test equipment other than approved GAL programming equipment. As shown in the Register Preload Waveform in Figure 5, the preload sequence must not begin until the normal power-up reset operation has completed (after time t_{RESET}). The device is placed into preload mode by raising the "PRLD" input (pin* 11) to voltage V_{IES} , as specified in the Register Preload Specifications (Table III).

To preload the OLMC registers, a series of data bits are shifted into the device on the "SDIN" input (pin* 9), one bit for each OLMC in which registered output has been selected. (Non-registered OLMCs are bypassed.) The shift sequence is clocked by the rising edge of the "DCLK" input (pin* 1). The data stream is shifted in through the registered OLMC with the lowest corresponding pin number, and then "upward" through all remaining registered OLMCs in pin-number ascending order. Therefore, the first data bit in the series is ultimately loaded into the registered OLMC with the highest corresponding pin number, as shown in Figure 4.

As the data series is shifted into the SDIN input, the contents of all registers (in registered OLMCs) are shifted "upward" and out onto the "SDOUT" output (pin* 12). Complete present-state information can be examined in this manner. Test fixtures can be devised to test several GAL devices in which the SDOUT pin of each chip is connected to the SDIN pin of the next, and all preload and present-state data can be shifted around a single serial loop.

Note that when shifting register data into SDIN or out of SDOUT, V_{IL}/V_{OL} = register reset (0), and V_{IH}/V_{OH} = register set (1). These 0 and 1 register states are always inverted (active-low) on the normal output pins regardless of the selected output polarity (polarity affects logic function values before register inputs).

*Applies to both 20-pin DIP and 20-lead PCC Packages for GAL16V8.

Register Preload (Continued)

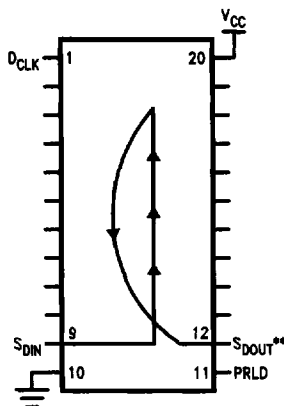

TL/L/9344-17

**The S_{DOUT} output buffer is an open drain output during preload. This pin should be terminated to V_{CC} with a 10 kΩ resistor.

FIGURE 4. Output Register Preload Pinout

Register Preload Specifications

TABLE III

| Symbol | Parameter | Conditions | Min | Typ | Max | Units |
|-----------------------------------|--|-----------------------------------|------|-----|-----------------|-------|
| V _{IH} | Input Voltage (High) | | 2.40 | | V _{CC} | V |
| V _{IL} | Input Voltage (Low) | | 0.00 | | 0.50 | V |
| V _{IES} | Registered Preload Input Voltage | | 14.5 | 15 | 15.5 | V |
| V _{OH} | Output Voltage (High) (Note 1) | | | | V _{CC} | V |
| V _{OL} | Output Voltage (Low) (Note 1) | I _{OL} ≤ 12 mA | 0.00 | | 0.50 | V |
| I _{IH} , I _{IL} | Input Current (Programming) | | | ± 1 | ± 10 | μA |
| I _{OH} | High Level Output Current (Note 1) | V _{OH} ≤ V _{CC} | | | 10 | μA |
| t _{PWV} | Verify Pulse Width | | 1 | 5 | 10 | μs |
| t _D | Pulse Sequence Delay | | 1 | 5 | 10 | μs |
| t _{RESET} | Register Reset Time from Valid V _{CC} | | | | 45 | μs |

Note 1: The S_{DOUT} output buffer is an open drain output. This pin should be terminated to V_{CC} with a 10k resistor.

Register Preload Waveforms

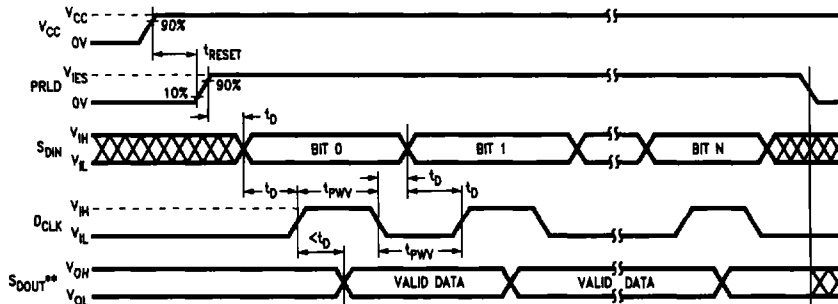

TL/L/9344-18

**The S_{DOUT} output buffer is an open drain output during preload. This pin should be terminated to V_{CC} with a 10 kΩ resistor.

FIGURE 5

Programming Details

Understanding the information in this section is not essential when using approved programming equipment and software for developing GAL designs. This is a more thorough disclosure of the GAL architecture provided for direct JEDEC cell-map editing and diagnostic purposes. This section alone, however, does not contain sufficient information to implement the GAL programming algorithm. If detailed specifications of the GAL programming algorithm are needed, please contact the National Semiconductor Programmable Device Support department.

As mentioned in the Functional Description, the OLMC is responsible for selecting input and/or output paths, registered vs. combinatorial outputs, active-high or low polarity, and common vs. locally-controlled TRI-STATE control. Additionally, the OLMCs select between alternate logic array input paths to maintain JEDEC cell-map compatibility with either "small-PAL" or "medium-PAL" logic arrays.

The various configurations of the OLMCs are controlled by a set of programmable "architecture" cells, separate from the logic-defining array cells. Each GAL device contains two "global" architecture cells, "SYN" and "AC0", which affect all OLMCs. Each of the device's eight OLMCs also contains two "local" cells, "AC1" and "XOR". The OLMC Logic Diagram in *Figure 6* shows how the architecture cells select the different paths through the OLMC.

The SYN bit controls whether a device will have any registered outputs (SYN = 0) or will be purely combinatorial (SYN = 1). The SYN bit determines whether device pins* 1 and 11 are used as the clock and global TRI-STATE control inputs (SYN=0) or whether they are ordinary inputs (SYN=1). The AC0 bit selects between the "Small-PAL" mode and the "Medium/Registered-PAL" modes. The function of the AC1 bits depend on the state of the AC0 bit. In "Small-PAL" mode (AC0=0), the AC1 bit in each OLMC determines whether the associated device pin is an output (AC1=0) or an input (AC1=1). In "Registered-PAL" mode (AC0=1), the AC1 bit determines whether each OLMC is registered (AC1=0) or combinatorial (AC1=1). In "Medium-PAL" mode (AC0=1), the AC1 bits in all OLMCs must be set to 1 (combinatorial). All of the valid architecture bit configurations are shown in the OLMC Architecture table (Table IV), which has the same familiar format used in the OLMC Selection table (Table I).

Independent of SYN, AC0 and the AC1 bits, the XOR bit in each OLMC selects between active-low (XOR=0) or active-high (XOR=1) output polarity.

*Applies to both 20-pin DIP and 20-lead PCC packages for GAL16V8.

OLMC Logic Diagram

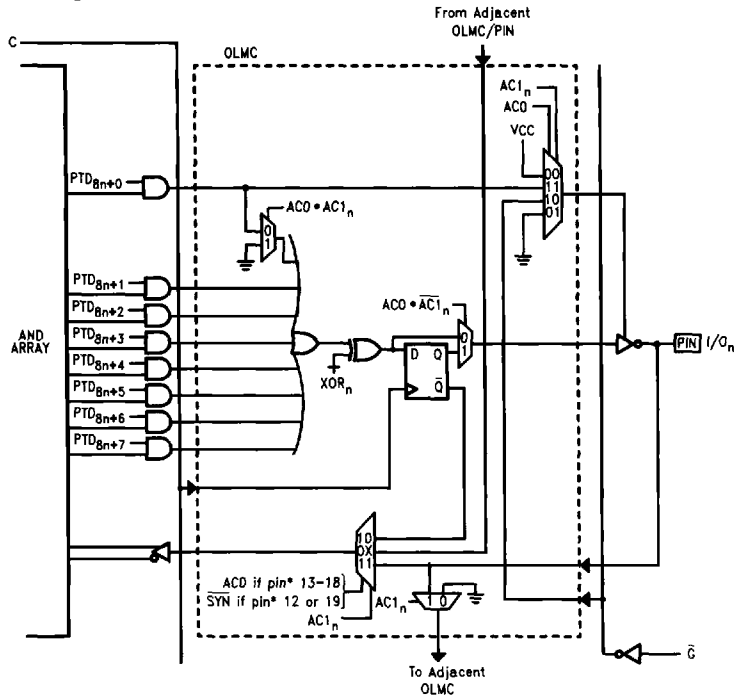

*Applies to both 20-pin DIP and 20-lead PCC packages for GAL16V8.

TL/L/8344-35

FIGURE 6

OLMC Architecture Programming

TABLE IV

| "Small-PAL" Mode | | | | "Registered-PAL" Mode | | | | "Medium-PAL" Mode | |
|------------------|---------|--|-------------|-----------------------|-----------|------------------------------------|-------------|---------------------------------|-------------------------------|
| Function | | JEDEC Input Line #s (Note 1) | | Function | | JEDEC Input Line #s (Note 1) | | Function | JEDEC Input Lines #s (Note 1) |
| Pin 1 | INPUT | INPUT | 2,3 | CLOCK | CLOCK | | | INPUT | 2,3 |
| *** Pin 19 | OUTPUT* | INPUT | 6,7 | REGISTER | I/O | 2,3 | | TRI-STATE** | |
| *** Pin 18 | OUTPUT* | INPUT | 10,11 | REGISTER | I/O | 6,7 | | I/O | 6,7 |
| *** Pin 17 | OUTPUT* | INPUT | 14,15 | REGISTER | I/O | 10,11 | | I/O | 10,11 |
| *** Pin 16 | OUTPUT* | NC | | REGISTER | I/O | 14,15 | | I/O | 14,15 |
| *** Pin 15 | OUTPUT* | NC | | REGISTER | I/O | 18,19 | | I/O | 18,19 |
| *** Pin 14 | OUTPUT* | INPUT | 18,19 | REGISTER | I/O | 22,23 | | I/O | 22,23 |
| *** Pin 13 | OUTPUT* | INPUT | 22,23 | REGISTER | I/O | 26,27 | | I/O | 26,27 |
| *** Pin 12 | OUTPUT* | INPUT | 26,27 | REGISTER | I/O | 30,13 | | TRI-STATE** | |
| Pin 11 | INPUT | INPUT | 30,31 | \bar{G} | \bar{G} | | | INPUT | 30,31 |
| | | $AC1_n = 0$ | $AC1_n = 1$ | | | $AC1_n = 0$ | $AC1_n = 1$ | | |
| | | SYN = 1, AC0 = 0 | | | | SYN = 0, AC0 = 1 | | | |
| | | All outputs are combinatorial and always active. | | | | At least one output is registered. | | | |
| | | | | | | | | All I/O pins are combinatorial. | |

Note: Pin numbers above apply to both 20-pin DIP and 20-lead PCC packages for GAL16V8.

Note 1: All even and odd numbered JEDEC input line numbers correspond to true and complement array inputs, respectively.

*Active combinatorial output.

**TRI-STATE combinatorial output.

*** $AC1_n$ applies to these I/O pins only.

GAL.16V8 Logic Diagram

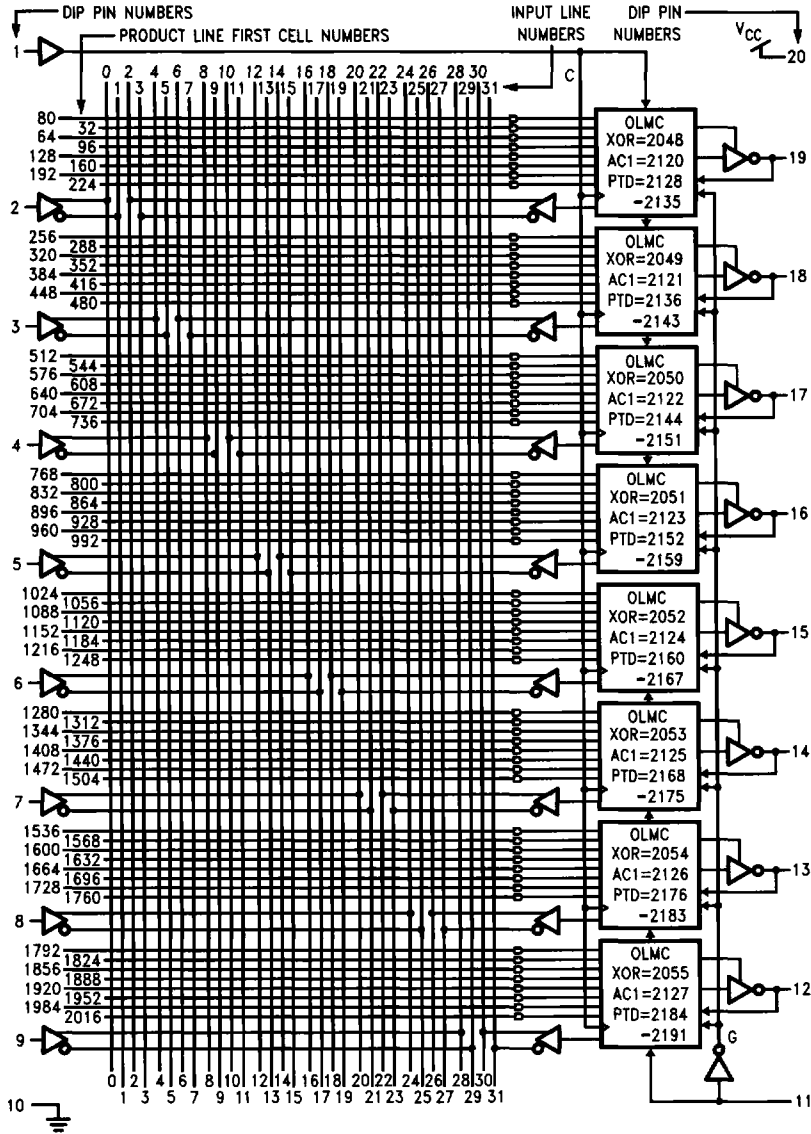

USER ELECTRONIC SIGNATURE WORD:

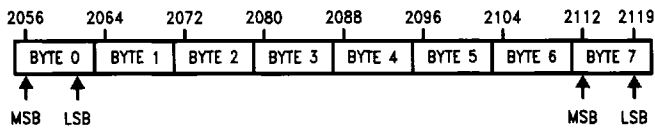

SYN=2192
ACO=2193

2

JEDEC: Logic Array Cell Number = Product Line First Cell Number + Input Line Number

FIGURE 7

TL/L/9344-36

Typical Performance Characteristics

