

74AC/ACT11074

Dual D-Type Flip-Flop w/Set and Reset; Positive-Edge Trigger

Product Specification

FEATURES

- Output capability: ± 24 mA
- CMOS (AC) and TTL (ACT) voltage level inputs
- 50 Ω incident wave switching
- Center-pin V_{CC} and ground configuration to minimize high-speed switching noise
- I_{CC} category: SSI

DESCRIPTION

The 74AC/ACT11074 high-performance CMOS devices combine very high speed and high output drive comparable to the most advanced TTL families.

The 74AC/ACT11074 provides two D-type flip-flops with independent Data, Clock, Set and Reset inputs, and complementary Q and \bar{Q} outputs.

Set (\bar{S}_n) and Reset (\bar{R}_n) are asynchronous active-Low inputs and operate independently of the Clock input. Information on the Data (D) input is transferred to the Q output on the Low-to-High transition of the clock pulse. Clock triggering occurs at a voltage level of the clock pulse and is not directly related to the transition time of the positive-going pulse. The D inputs must be stable one set-up time prior to the Low-to-High clock transition for predictable operation.

GENERAL INFORMATION

SYMBOL	PARAMETER	CONDITIONS $T_A = 25^\circ\text{C}$; GND = 0V; $V_{CC} = 5.0\text{V}$	TYPICAL		UNIT
			AC	ACT	
t_{PLH}/t_{PHL}	Propagation delay CP_n to Q_n or \bar{Q}_n	$C_L = 50\text{pF}$	5.2	5.9	ns
C_{PD}	Power dissipation capacitance per flip-flop ¹	$f = 1\text{MHz}$; $C_L = 50\text{pF}$	30	30	pF
C_{IN}	Input capacitance	$V_I = 0\text{V}$ or V_{CC}	3.5	3.5	pF
I_{LATCH}	Latch-up current	Per Jeduc JC40.2 Standard 17	500	500	mA
f_{MAX}	Maximum clock frequency	$C_L = 50\text{pF}$	150	125	MHz

Note:

1. C_{PD} is used to determine the dynamic power dissipation (P_D in μW):

$$P_D = C_{PD} \times V_{CC}^2 \times f_i + \sum (C_L \times V_{CC}^2 \times f_o) \text{ where:}$$

f_i = input frequency in MHz, C_L = output load capacitance in pF,

f_o = output frequency in MHz, V_{CC} = supply voltage in V,

$\sum (C_L \times V_{CC}^2 \times f_o)$ = sum of outputs

ORDERING INFORMATION

PACKAGES	TEMPERATURE RANGE	ORDER CODE
14-pin plastic DIP (300mil-wide)	-40°C to +85°C	74AC11074N 74ACT11074N
14-pin plastic SO (150mil-wide)	-40°C to +85°C	74AC11074D 74ACT11074D

PIN CONFIGURATION

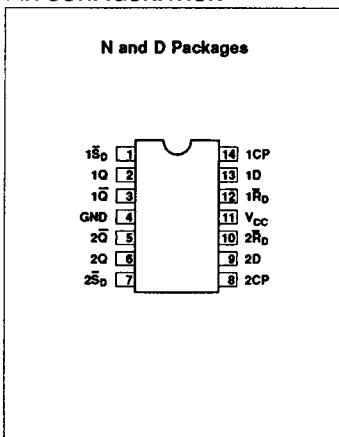

LOGIC SYMBOL

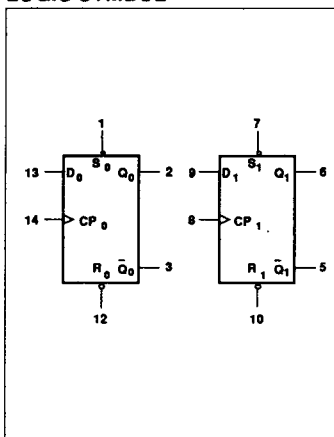

LOGIC SYMBOL (IEEE/IEC)

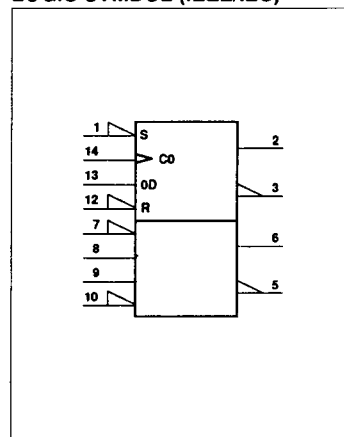

Dual D-Type Flip-Flop w/Set and Reset; Positive-Edge Trigger

74AC/ACT11074

PIN DESCRIPTION

PIN NUMBER	SYMBOL	NAME AND FUNCTION
13, 9	$D_0 - D_1$	Data inputs
2, 6	$Q_0 - Q_1$	Data outputs
3, 5	$\bar{Q}_0 - \bar{Q}_1$	Data outputs (complements of Q_n outputs)
1, 7	$\bar{S}_0 - \bar{S}_1$	Set inputs (active Low)
12, 10	$\bar{R}_0 - \bar{R}_1$	Reset inputs (active Low)
14, 8	$CP_0 - CP_1$	Clock inputs
4	GND	Ground (0V)
11	V_{CC}	Positive supply voltage

FUNCTION TABLE

OPERATING MODE	INPUTS				OUTPUTS	
	\bar{S}	\bar{R}	CP	D	Q	\bar{Q}
Asynchronous set	L	H	X	X	H	L
Asynchronous reset	H	L	X	X	L	H
Undetermined ¹	L	L	X	X	H	H
Load "1" (set)	H	H	↑	h	H	L
Load "0" (reset)	H	H	↑	l	L	H
No change – hold	H	H	L	X	Q_0	\bar{Q}_0

H = High voltage level steady state
 h = High voltage level one set-up time prior to the Low-to-High clock transition
 L = Low voltage level steady state
 l = Low voltage level one set-up time prior to the Low-to-High clock transition
 X = Don't care
 ↑ = Low-to-High clock transition

NOTE:

- This configuration is nonstable; that is, it will not persist when either Set or Reset returns to its inactive (High) level.

LOGIC DIAGRAM

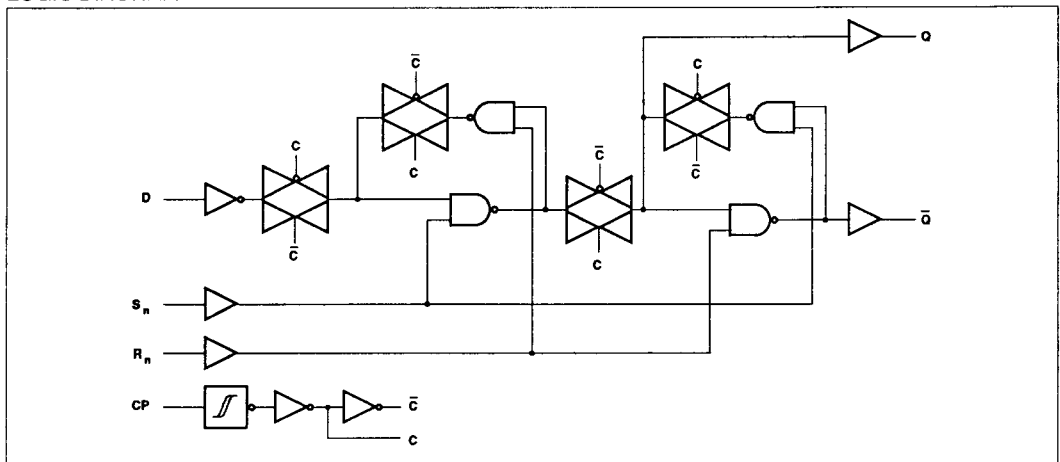

Dual D-Type Flip-Flop w/Set and Reset; Positive-Edge Trigger

74AC/ACT11074

RECOMMENDED OPERATING CONDITIONS

SYMBOL	PARAMETER	74AC11074			74ACT11074			UNIT
		Min	Nom	Max	Min	Nom	Max	
V_{CC}	DC supply voltage	3.0 ¹	5.0	5.5	4.5	5.0	5.5	V
V_I	Input voltage	0		V_{CC}	0		V_{CC}	V
V_O	Output voltage	0		V_{CC}	0		V_{CC}	V
$\Delta V/\Delta v$	Input transition rise or fall rate	0		10	0		10	ns/V
T_A	Operating free-air temperature	-40		+85	-40		+85	°C

NOTE:

- No electrical or switching characteristics are specified at $V_{CC} < 3V$. Operation between 2V and 3V is not recommended, but within that range, a device output will maintain a previously established logic state.

ABSOLUTE MAXIMUM RATINGS¹

SYMBOL	PARAMETER	TEST CONDITIONS	RATING	UNIT
V_{CC}	DC supply voltage		-0.5 to +7.0	V
I_{IK} or V_I	DC input diode current ²	$V_I < 0$	-20	mA
		$V_I > V_{CC}$	20	
	DC input voltage		-0.5 to $V_{CC} + 0.5$	V
I_{OK} or V_O	DC output diode current ²	$V_O < 0$	-50	mA
		$V_O > V_{CC}$	50	
	DC output voltage		-0.5 to $V_{CC} + 0.5$	V
I_O	DC output source or sink current per output pin	$V_O = 0$ to V_{CC}	±50	mA
I_{CC} or I_{GND}	DC V_{CC} current		±100	mA
	DC ground current		±100	
T_{STG}	Storage temperature		-65 to 150	°C
P_{TOT}	Power dissipation per package Plastic DIP	Above 70°C: derate linearly by 8mW/K	500	mW
	Power dissipation per package Plastic surface mount (SO)	Above 70°C: derate linearly by 6mW/K	400	mW

NOTES:

- Stresses beyond those listed may cause permanent damage to the device. These are stress ratings only and functional operation of the device at these or any other conditions beyond those indicated under "recommended operating conditions" is not implied. Exposure to absolute-maximum-rated conditions for extended periods may affect device reliability.
- The input and output voltage ratings may be exceeded if the input and output current ratings are observed.

Dual D-Type Flip-Flop w/Set and Reset;
Positive-Edge Trigger

74AC/ACT11074

DC ELECTRICAL CHARACTERISTICS

SYMBOL	PARAMETER	TEST CONDITIONS	V _{CC}	74AC11074				74ACT11074				UNIT	
				T _A = +25°C		T _A = -40°C to +85°C		T _A = +25°C		T _A = -40°C to +85°C			
				Min	Max	Min	Max	Min	Max	Min	Max		
V _{IH}	High-level input voltage		3.0	2.10		2.10						V	
			4.5	3.15		3.15		2.0		2.0			
			5.5	3.85		3.85		2.0		2.0			
V _{IL}	Low-level input voltage		3.0		0.90		0.90					V	
			4.5		1.35		1.35		0.8		0.8		
			5.5		1.65		1.65		0.8		0.8		
V _{OH}	High-level output voltage	V _I = V _{IL} or V _{IH}	I _{OH} = -50μA	3.0	2.9		2.9					V	
				4.5	4.4		4.4		4.4		4.4		
			5.5	5.4		5.4		5.4		5.4			
			I _{OH} = -4mA	3.0	2.58		2.48						
				4.5	3.94		3.8		3.94		3.8		
			5.5	4.94		4.8		4.94		4.8			
I _{OH} = -75mA ¹	5.5			3.85				3.85					
V _{OL}	Low-level output voltage	V _I = V _{IL} or V _{IH}	I _{OL} = 50μA	3.0		0.1		0.1				V	
				4.5		0.1		0.1		0.1			0.1
			5.5		0.1		0.1		0.1		0.1		
			I _{OL} = 12mA	3.0		0.36		0.44					
				4.5		0.36		0.44		0.36			0.44
			5.5		0.36		0.44		0.36		0.44		
I _{OL} = 75mA ¹	5.5				1.65				1.65				
I _I	Input leakage current	V _I = V _{CC} or GND	5.5		±0.1		±1.0		±0.1		±1.0	μA	
I _{CC}	Quiescent supply current	V _I = V _{CC} or GND, I _O = 0	5.5		4.0		40		4.0		40	μA	
ΔI _{CC}	Supply current, TTL inputs High ²	One input at 3.4V, other inputs at V _{CC} or GND	5.5						0.9		1.0	mA	

NOTES:

- Not more than one output should be tested at a time, and the duration of the test should not exceed 10ms.
- This is the increase in supply current for each input that is at one of the specified TTL voltage levels rather than 0V or V_{CC}.

Dual D-Type Flip-Flop w/Set and Reset; Positive-Edge Trigger

74AC/ACT11074

AC ELECTRICAL CHARACTERISTICS AT 3.3V $\pm 0.3V$

SYMBOL	PARAMETER	WAVEFORM	74AC11074					UNIT
			$T_A = +25^\circ\text{C}$			$T_A = -40^\circ\text{C to } +85^\circ\text{C}$		
			Min	Typ	Max	Min	Max	
f_{MAX}	Maximum clock frequency	1	100	125		100		MHz
t_{PLH} t_{PHL}	Propagation delay CP_n to $\text{Q}_n, \overline{\text{Q}}_n$	1	1.5 1.5	7.7 7.3	10.5 9.7	1.5 1.5	11.3 10.6	ns
t_{PLH} t_{PHL}	Propagation delay $\overline{\text{S}}_n, \overline{\text{R}}_n$ to $\text{Q}_n, \overline{\text{Q}}_n$	2	1.5 1.5	5.8 6.5	9.3 11.4	1.5 1.5	10.0 12.2	ns
t_{S}	Setup time, High or Low D_n to CP_n	1	5.0			5.0		ns
t_{H}	Hold time, High or Low CP_n to D_n	1	0			0		ns
t_{W}	Clock pulse width High or Low	1	5.0			5.0		ns
t_{W}	$\overline{\text{S}}_n$ or $\overline{\text{R}}_n$ pulse width, Low	2	4.0			4.0		ns
t_{REC}	Recovery time $\overline{\text{S}}_n$ or $\overline{\text{R}}_n$ to CP_n	3	1.0			1.0		ns

AC ELECTRICAL CHARACTERISTICS AT 5.0V $\pm 0.5V$

SYMBOL	PARAMETER	WAVEFORM	74AC11074					UNIT
			$T_A = +25^\circ\text{C}$			$T_A = -40^\circ\text{C to } +85^\circ\text{C}$		
			Min	Typ	Max	Min	Max	
f_{MAX}	Maximum clock frequency	1	125	150		125		MHz
t_{PLH} t_{PHL}	Propagation delay CP_n to $\text{Q}_n, \overline{\text{Q}}_n$	1	1.5 1.5	5.4 5.0	7.5 6.9	1.5 1.5	8.2 7.5	ns
t_{PLH} t_{PHL}	Propagation delay $\overline{\text{S}}_n, \overline{\text{R}}_n$ to $\text{Q}_n, \overline{\text{Q}}_n$	2	1.5 1.5	4.2 4.7	6.6 8.2	1.5 1.5	7.1 9.0	ns
t_{S}	Setup time, High or Low D_n to CP_n	1	3.5			3.5		ns
t_{H}	Hold time, High or Low CP_n to D_n	1	0			0		ns
t_{W}	Clock pulse width High or Low	1	4.0			4.0		ns
t_{W}	$\overline{\text{S}}_n$ or $\overline{\text{R}}_n$ pulse width, Low	2	4.0			4.0		ns
t_{REC}	Recovery time $\overline{\text{S}}_n$ or $\overline{\text{R}}_n$ to CP_n	3	1.0			1.0		ns

Dual D-Type Flip-Flop w/Set and Reset;
Positive-Edge Trigger

74AC/ACT11074

AC ELECTRICAL CHARACTERISTICS AT 5.0V ±0.5V

SYMBOL	PARAMETER	WAVEFORM	74ACT11074					UNIT
			T _A = +25°C			T _A = -40°C to +85°C		
			Min	Typ	Max	Min	Max	
f _{MAX}	Maximum clock frequency	1	100	125		100		MHZ
t _{PLH} t _{PHL}	Propagation delay CP _n to Q _n , \bar{Q}_n	1	1.5	6.0	8.5	1.5	9.4	ns
t _{PLH} t _{PHL}	Propagation delay \bar{S}_n , \bar{R}_n to Q _n , \bar{Q}_n	2	1.5	5.7	8.9	1.5	9.6	ns
t _S	Setup time, High or Low D _n to CP _n	1	4.5			4.5		ns
t _H	Hold time, High or Low CP _n to D _n	1	0			0		ns
t _W	Clock pulse width High or Low	1	5.0			5.0		ns
t _W	\bar{S}_n or \bar{R}_n pulse width, Low	2	5.0			5.0		ns
t _{REC}	Recovery time \bar{S}_n or \bar{R}_n to CP _n	3	2.0			2.0		ns

AC WAVEFORMS

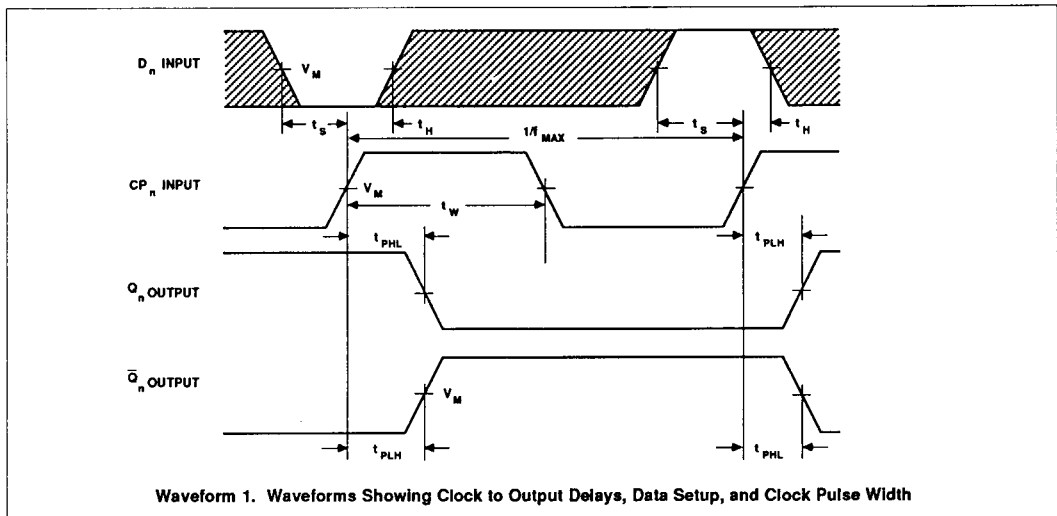

Dual D-Type Flip-Flop w/Set and Reset;
Positive-Edge Trigger

74AC/ACT11074

AC WAVEFORMS (Continued)

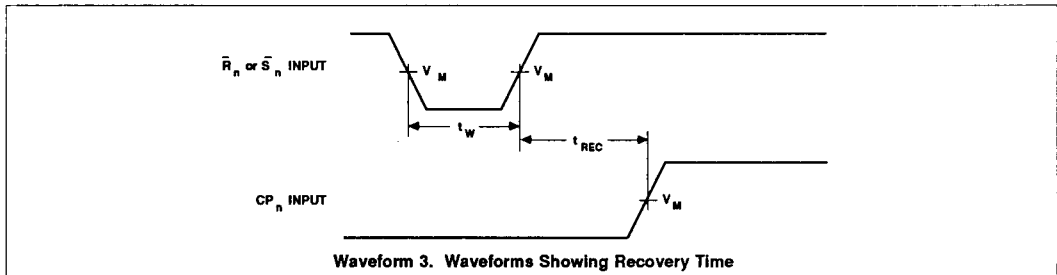
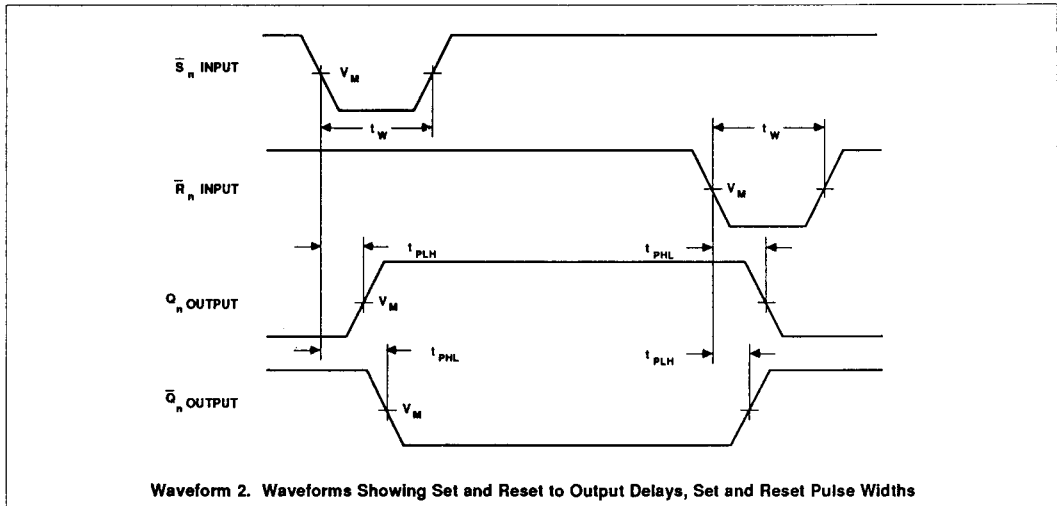

WAVEFORM CONDITIONS

	INPUTS	OUTPUTS
AC	$V_{IN} = \text{GND to } V_{CC}$, $V_M = 50\% V_{CC}$	$V_{OUT} = V_{OL} \text{ to } V_{OH}$
ACT	$V_{IN} = \text{GND to } 3.0\text{V}$, $V_M = 1.5\text{V}$	$V_M = 50\% V_{CC}$

Dual D-Type Flip-Flop w/Set and Reset; Positive-Edge Trigger

74AC/ACT11074

TEST CIRCUIT

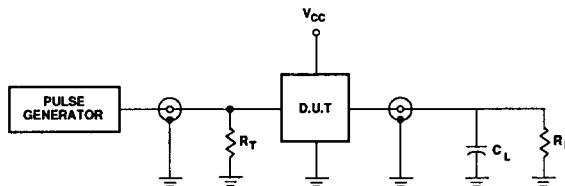

Test Circuit

DEFINITIONS

C_L = Load capacitance, 50pF; includes jig
and probe capacitance

R_L = Load resistor, 500 Ω

R_T = Termination resistance should be
equal to Z_{OUT} of pulse generators

Input pulses: PRR \leq 10MHz

$t_r = t_f = 3ns$

Packaging Information

T-90-20

14-PIN PLASTIC SMALL OUTLINE (SO)

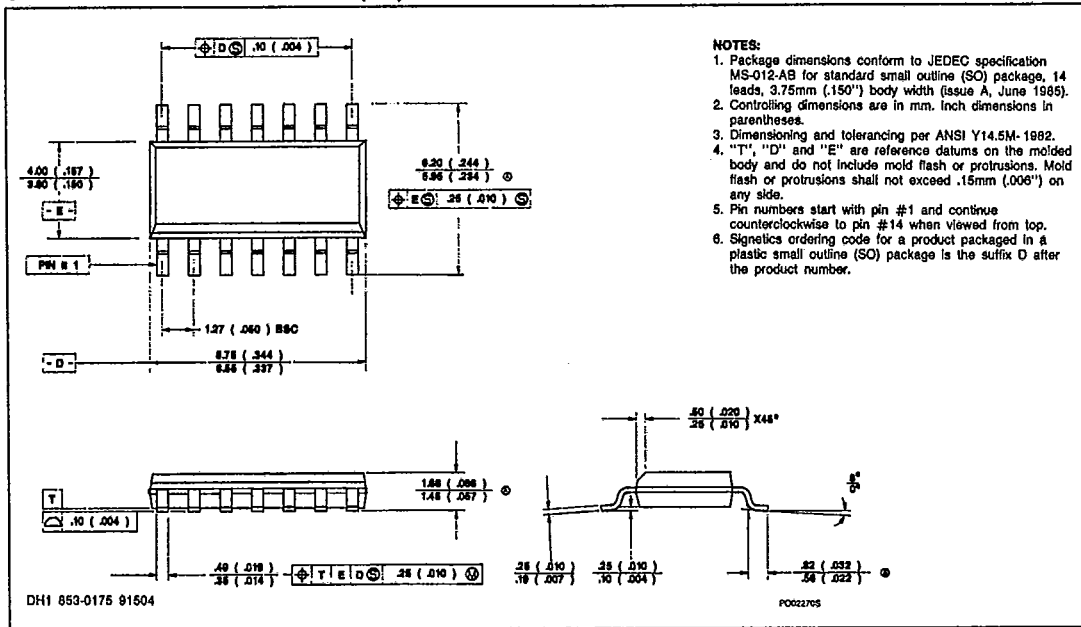

16-PIN PLASTIC SMALL OUTLINE (SO)

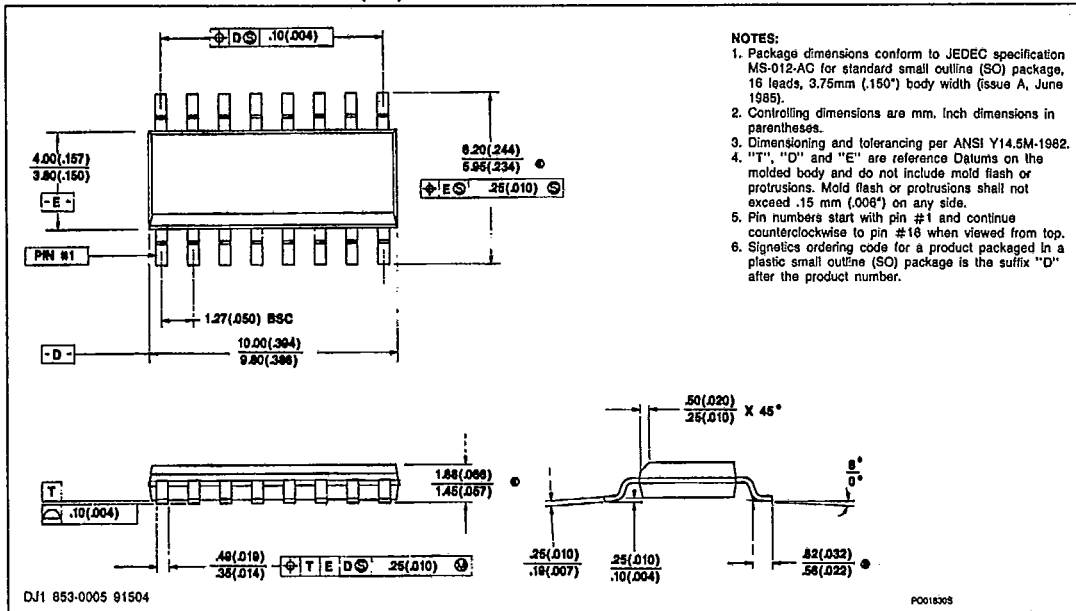

Packaging Information

16-PIN PLASTIC SMALL OUTLINE (SOL)

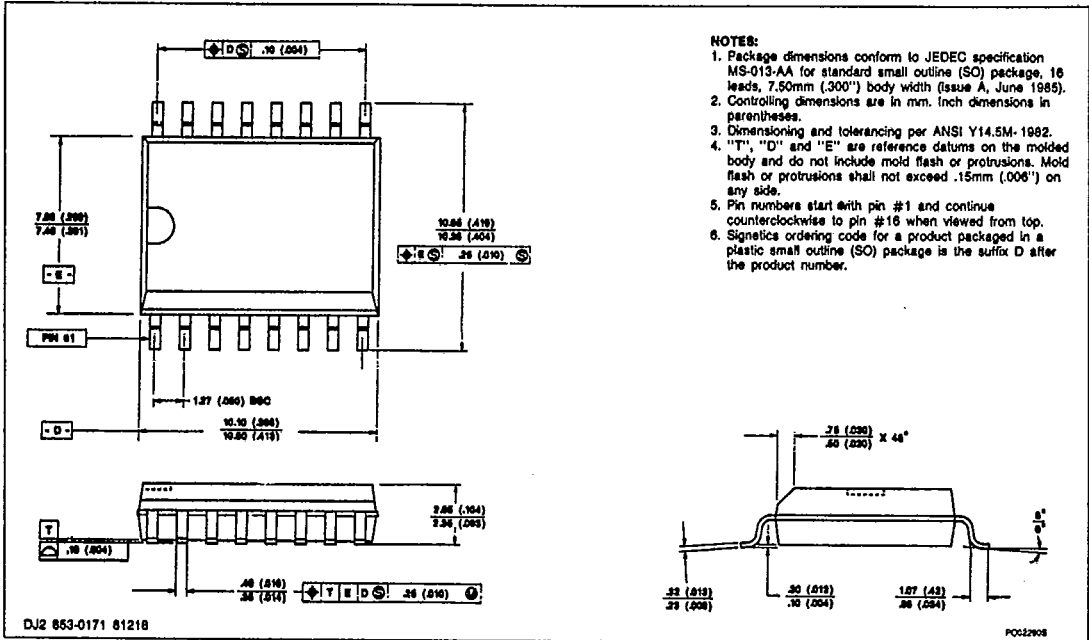

20-PIN PLASTIC SMALL OUTLINE (SOL)

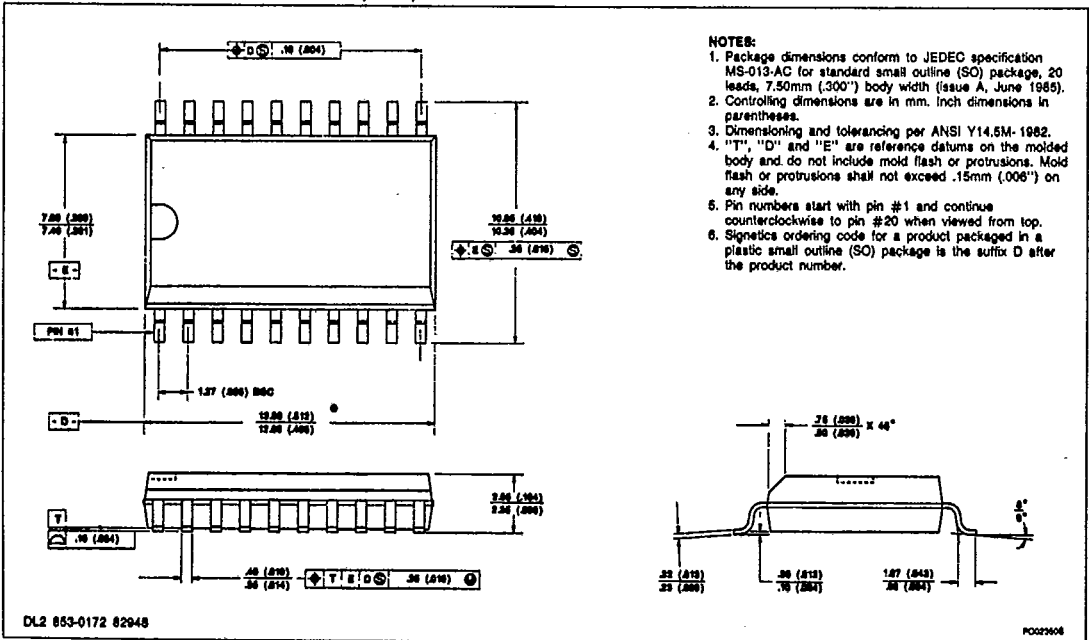

Packaging Information

24-PIN PLASTIC SMALL OUTLINE (SOL)

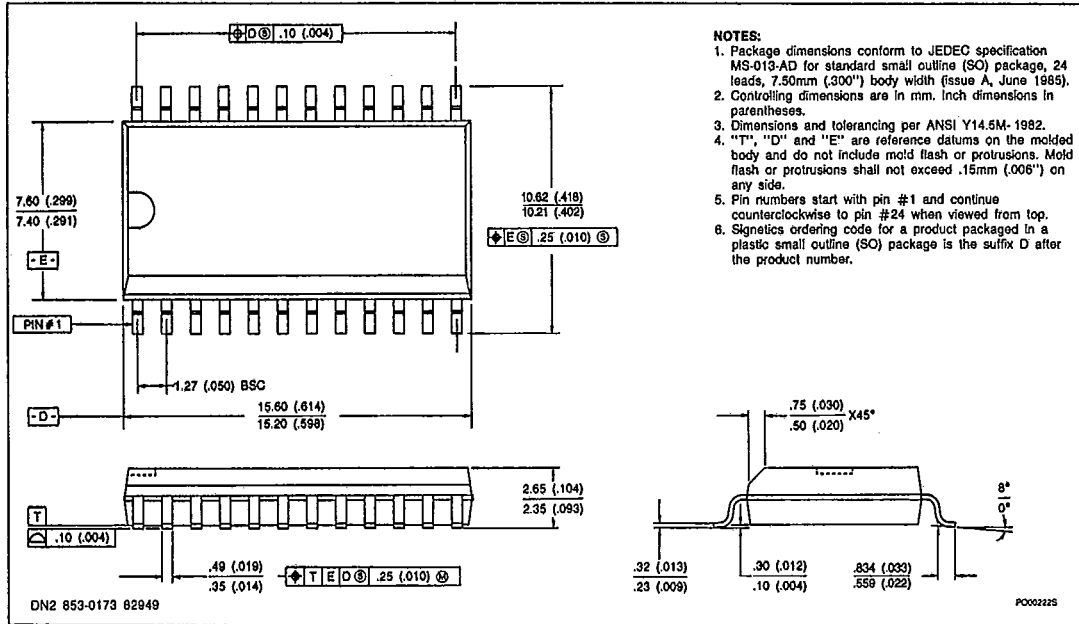

28-PIN PLASTIC SMALL OUTLINE (SOL)

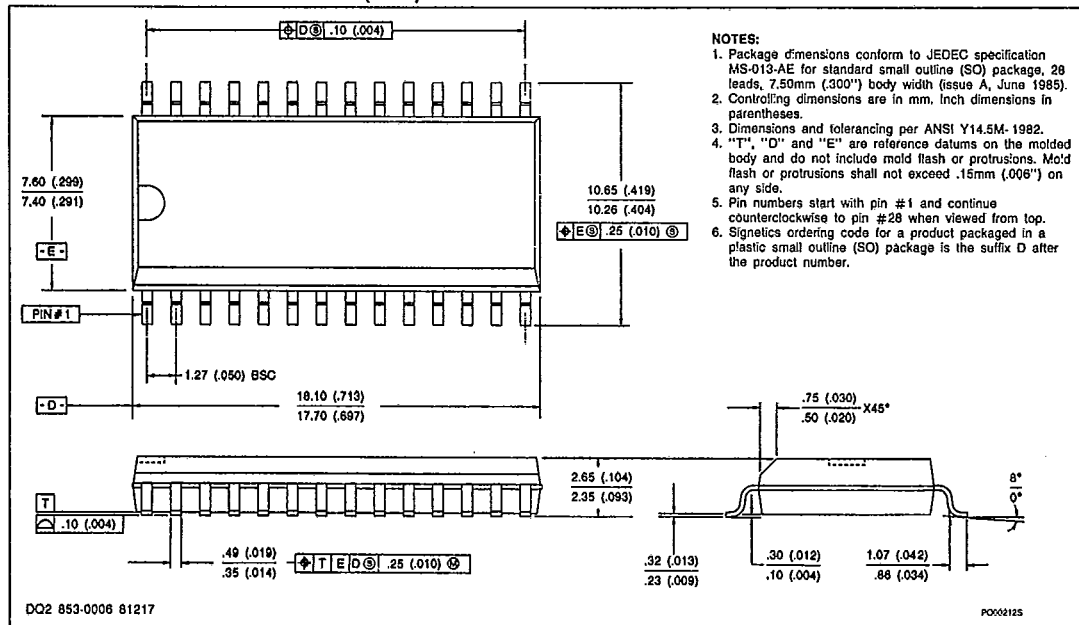

Packaging Information

T-90-20

14-PIN PLASTIC DUAL IN-LINE (PDIP)

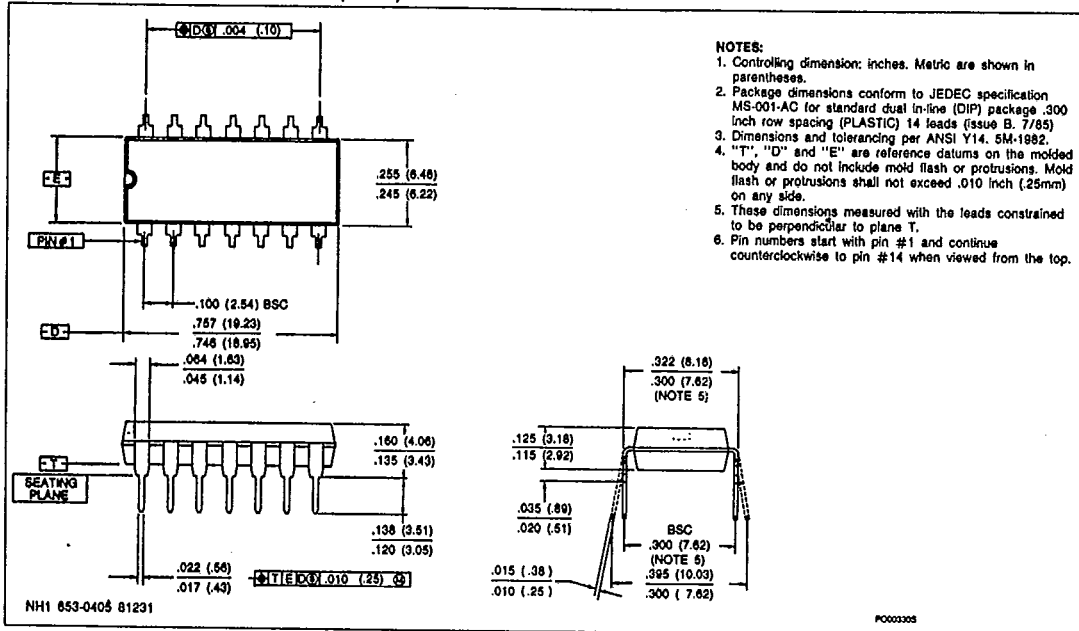

16-PIN PLASTIC DUAL IN-LINE (PDIP)

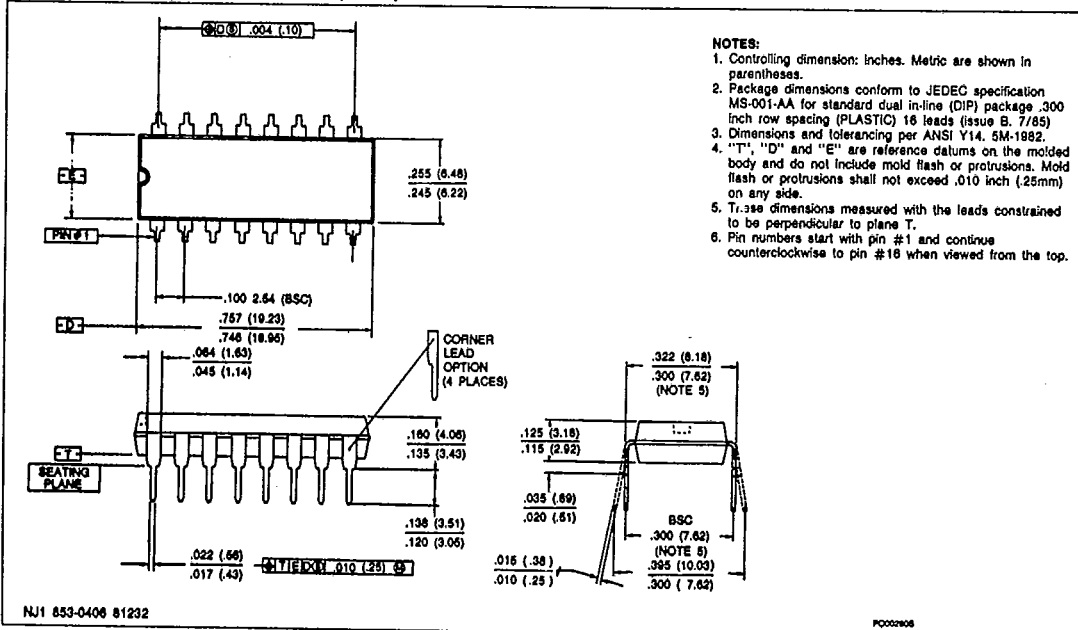

Packaging Information

T-90-20

20-PIN PLASTIC DUAL IN-LINE (PDIP)

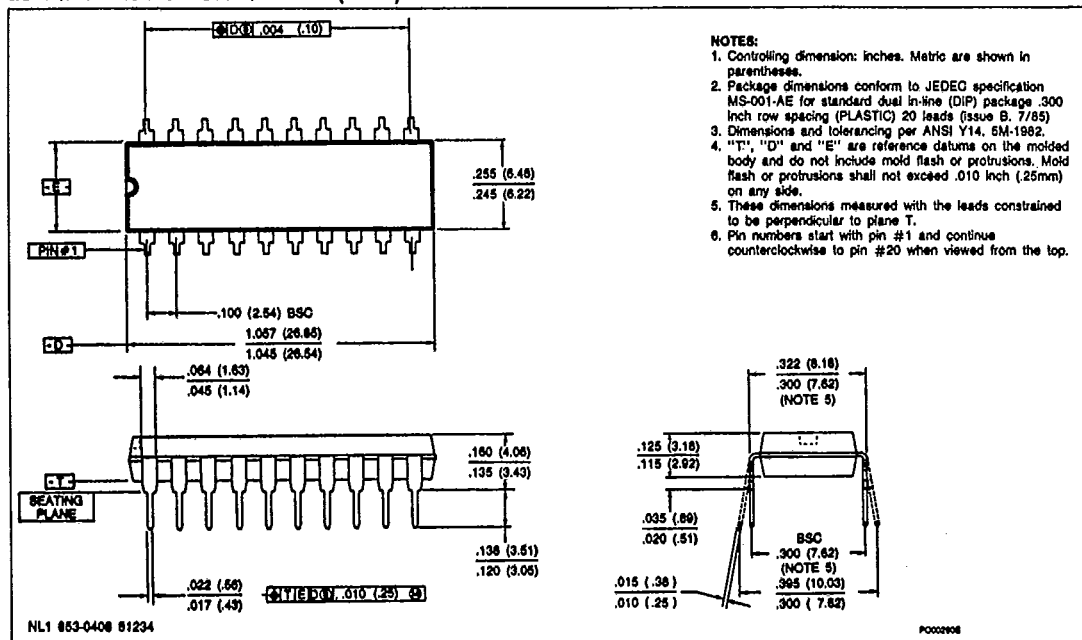

24-PIN PLASTIC DUAL IN-LINE (PDIP)

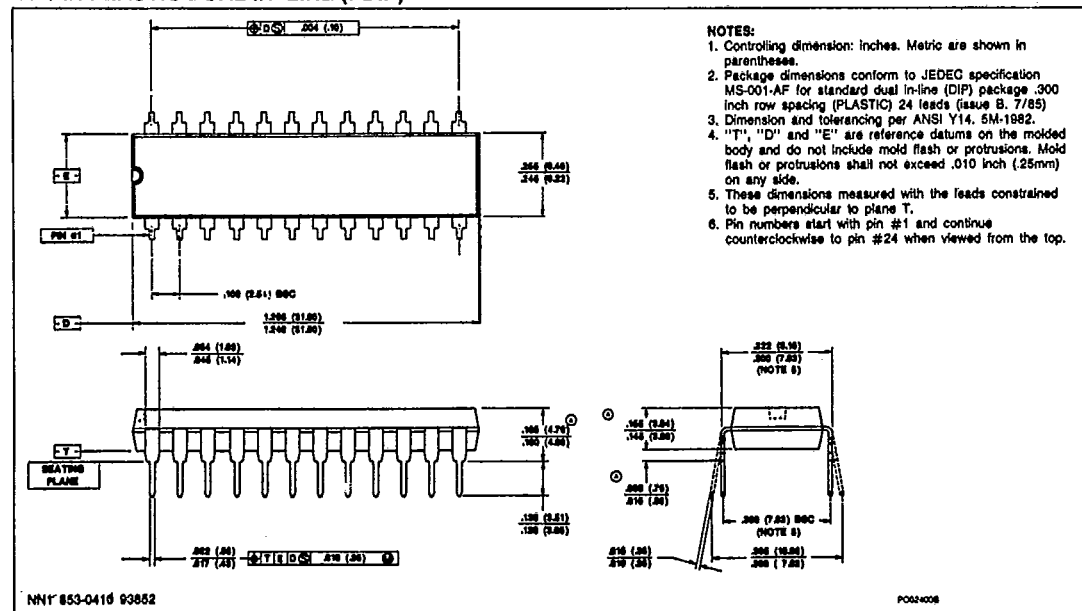

Packaging Information

28-PIN PLASTIC DUAL IN-LINE (PDIP) (300-mil-wide)

