

74ACT11258

QUADRUPLE 2-LINE TO 1-LINE DATA SELECTOR/MULTIPLEXER WITH 3-STATE OUTPUTS

SCAS056A – D327B, JANUARY 1989 – REVISED APRIL 1993

- Inputs Are TTL-Voltage Compatible
- 3-State Outputs Interface Directly With System Bus
- Flow-Through Architecture to Optimize PCB Layout
- Center-Pin V_{CC} and GND Configurations Minimize High-Speed Switching Noise
- EPIC™ (Enhanced-Performance Implanted CMOS) 1- μ m Process
- 500-mA Typical Latch-Up Immunity at 125°C
- Provides Bus Interface from Multiple Sources in High-Performance Systems
- Package Options Include Plastic Small-Outline Packages and Standard Plastic 300-mil DIPs

DW OR N PACKAGE
(TOP VIEW)

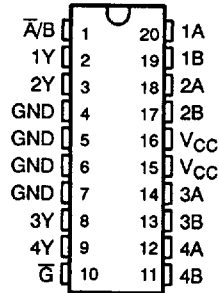

description

The 74ACT11258 is designed to multiplex signals from 4-bit data sources to 4-output data lines in bus-organized systems. The 3-state outputs will not load the data lines when the output control pin (\bar{G}) is at a high logic level.

The 74ACT11258 is characterized for operation from -40°C to 85°C .

FUNCTION TABLE

OUTPUT CONTROL \bar{G}	INPUTS		OUTPUT Y	
	SELECT \bar{A}/\bar{B}	DATA		
		A		B
H	X	X	X	Z
L	L	L	X	H
L	L	H	X	L
L	H	X	L	H
L	H	X	H	L

EPIC is a trademark of Texas Instruments Incorporated.

PRODUCTION DATA Information is current as of publication date. Products conform to specifications per the terms of Texas Instruments standard warranty. Production processing does not necessarily include testing of all parameters.

Copyright © 1993, Texas Instruments Incorporated



POST OFFICE BOX 655303 • DALLAS, TEXAS 75265

74ACT11258 QUADRUPLE 2-LINE TO 1-LINE DATA SELECTOR/MULTIPLEXER WITH 3-STATE OUTPUTS

SCAS056A - D3278, JANUARY 1989 - REVISED APRIL 1993

logic symbol†

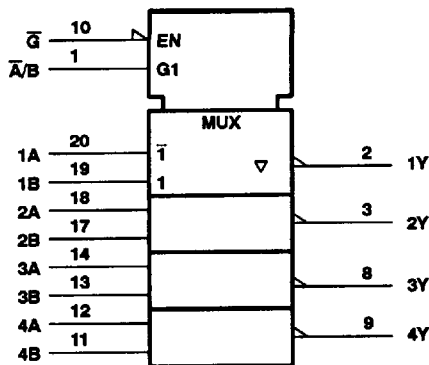

† This symbol is in accordance with ANSI/IEEE Std 91-1984 and IEC Publication 617-12.

logic diagram (positive logic)

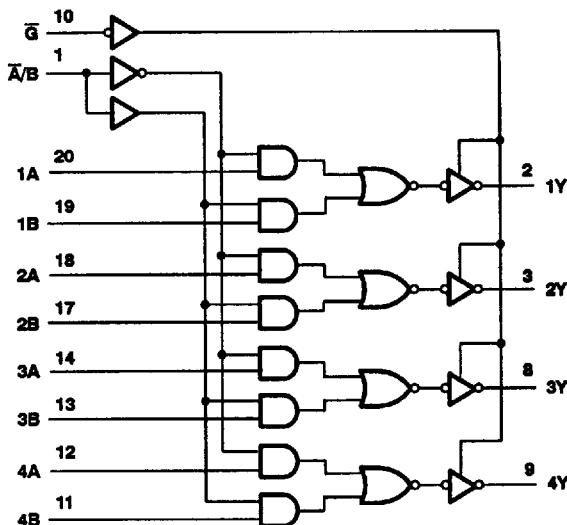

absolute maximum ratings over operating free-air temperature range (unless otherwise noted)‡

Supply voltage range, V_{CC}	- 0.5 V to 7 V
Input voltage range, V_I (see Note 1)	- 0.5 V to $V_{CC} + 0.5$ V
Output voltage range, V_O (see Note 1)	- 0.5 V to $V_{CC} + 0.5$ V
Input clamp current, I_{IK} ($V_I < 0$ or $V_I > V_{CC}$)	± 20 mA
Output clamp current, I_{OK} ($V_O < 0$ or $V_O > V_{CC}$)	± 50 mA
Continuous output current, I_O ($V_O = 0$ to V_{CC})	± 50 mA
Continuous current through V_{CC} or GND	± 100 mA
Storage temperature range	- 65°C to 150°C

‡ Stresses beyond those listed under "absolute maximum ratings" may cause permanent damage to the device. These are stress ratings only and functional operation of the device at these or any other conditions beyond those indicated under "recommended operating conditions" is not implied. Exposure to absolute-maximum-rated conditions for extended periods may affect device reliability.

NOTE 1: The input and output voltage ratings may be exceeded if the input and output current ratings are observed.

recommended operating conditions

	MIN	MAX	UNIT
V_{CC} Supply voltage	4.5	5.5	V
V_{IH} High-level input voltage	2		V
V_{IL} Low-level input voltage		0.8	V
V_I Input voltage	0	V_{CC}	V
V_O Output voltage	0	V_{CC}	V
I_{OH} High-level output current		-24	mA
I_{OL} Low-level output current		24	mA
$\Delta t/\Delta v$ Input transition rise or fall rate	0	10	ns/V
T_A Operating free-air temperature	-40	85	°C

8961723 0094536 3T1

TEXAS
INSTRUMENTS

POST OFFICE BOX 655303 • DALLAS, TEXAS 75265

74ACT11258
**QUADRUPLE 2-LINE TO 1-LINE DATA SELECTOR/MULTIPLEXER
 WITH 3-STATE OUTPUTS**

SCAS056A - D327B, JANUARY 1989 - REVISED APRIL 1993

electrical characteristics over recommended operating free-air temperature range (unless otherwise noted)

PARAMETER	TEST CONDITIONS	V _{CC}	T _A = 25°C			MIN	MAX	UNIT
			MIN	TYP	MAX			
V _{OH}	I _{OH} = -50 μA	4.5 V	4.4			4.4		V
		5.5 V	5.4			5.4		
	I _{OH} = -24 mA	4.5 V	3.94			3.8		
		5.5 V	4.94			4.8		
I _{OH} = -75 mA†	5.5 V				3.85			
V _{OL}	I _{OL} = 50 μA	4.5 V				0.1		V
		5.5 V				0.1		
	I _{OL} = 24 mA	4.5 V				0.36		
		5.5 V				0.36		
I _{OL} = 75 mA†	5.5 V				1.65			
I _{OZ}	V _O = V _{CC} or GND	5.5 V				± 0.5		μA
I _I	V _I = V _{CC} or GND	5.5 V				± 0.1		μA
I _{CC}	V _I = V _{CC} or GND, I _O = 0	5.5 V				8		μA
ΔI _{CC} ‡	One input at 3.4 V, Other inputs at V _{CC} or GND	5.5 V				0.9		mA
C _i	V _I = V _{CC} or GND	5 V				3.5		pF
C _o	V _O = V _{CC} or GND	5 V				8		pF

† Not more than one output should be tested at a time, and the duration of the test should not exceed 10 ms.

‡ This is the increase in supply current for each input that is at one of the specified TTL voltage levels rather than 0 V to V_{CC}.

switching characteristics over recommended ranges of supply voltage and operating free-air temperature (unless otherwise noted) (see Figure 1)

PARAMETER	FROM (INPUT)	TO (OUTPUT)	T _A = 25°C			MIN	MAX	UNIT
			MIN	TYP	MAX			
t _{PLH}	A or B	Any Y	1.5	5.4	7.7	1.5	8.5	ns
t _{PHL}			1.5	5.7	7.7	1.5	8.7	
t _{PLH}	A/B	Any Y	1.5	5.7	8	1.5	8.8	ns
t _{PHL}			1.5	6.7	9.4	1.5	10.4	
t _{PZH}	G	Any Y	1.5	5.7	8.1	1.5	8.8	ns
t _{PZL}			1.5	6.4	8.8	1.5	9.8	
t _{PHZ}	G	Any Y	1.5	6.1	7.5	1.5	7.7	ns
t _{PLZ}			1.5	6.3	8.3	1.5	9	

operating characteristics, V_{CC} = 5 V, T_A = 25°C

PARAMETER	TEST CONDITIONS	TYP	UNIT
C _{pD} Power dissipation capacitance	Outputs enabled	35	pF
	Outputs disabled	15	



74ACT11258
QUADRUPLE 2-LINE TO 1-LINE DATA SELECTOR/MULTIPLEXER
WITH 3-STATE OUTPUTS

SCAS056A - D3278, JANUARY 1989 - REVISED APRIL 1993

PARAMETER MEASUREMENT INFORMATION

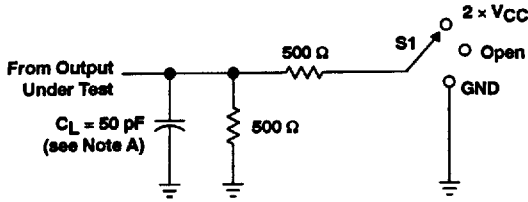

LOAD CIRCUIT

TEST	S1
t_{PLH}/t_{PHL}	Open
t_{PLZ}/t_{PZL}	2 x V_{CC}
t_{PHZ}/t_{PZH}	GND

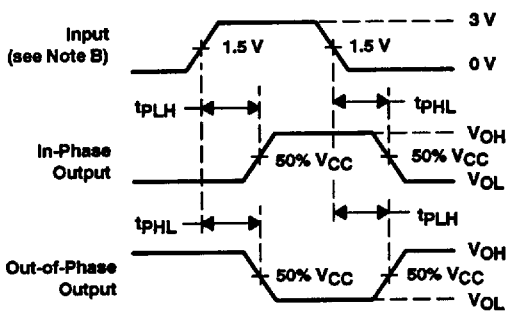

VOLTAGE WAVEFORMS

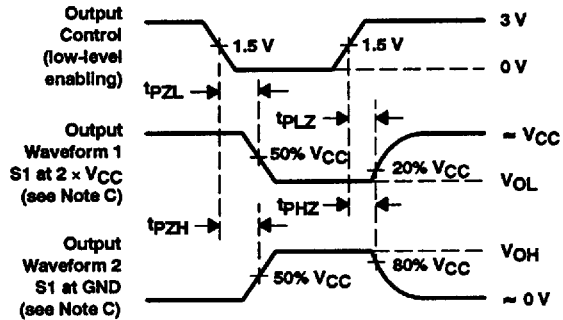

VOLTAGE WAVEFORMS

- NOTES: A. C_L includes probe and jig capacitance.
 B. All input pulses are supplied by generators having the following characteristics: $PRR \leq 10 \text{ MHz}$, $Z_O = 50 \Omega$, $t_r = 3 \text{ ns}$, $t_f = 3 \text{ ns}$.
 C. Waveform 1 is for an output with internal conditions such that the output is low except when disabled by the output control. Waveform 2 is for an output with internal conditions such that the output is high except when disabled by the output control.
 D. The outputs are measured one at a time with one input transition per measurement.

Figure 1. Load Circuit and Voltage Waveforms