

# RN114, 115, 116 RN117, 118

(RN1114)

SWITCHING, INVERTER CIRCUIT, INTERFACE CIRCUIT  
AND DRIVER CIRCUIT APPLICATIONS.

- With Built-in Bias Resistors
- Simplify Circuit Design
- Reduce a Quantity of Parts and Manufacturing Process
- Complementary to RN2114~RN2118

EQUIVALENT CIRCUIT AND BIAS RESISTOR VALUES

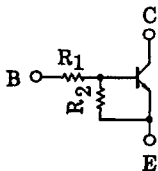

TYPE No.	R <sub>1</sub> (kΩ)	R <sub>2</sub> (kΩ)
RN1114	1	10
RN1115	2.2	10
RN1116	4.7	10
RN1117	10	4.7
RN1118	47	10

Unit in mm

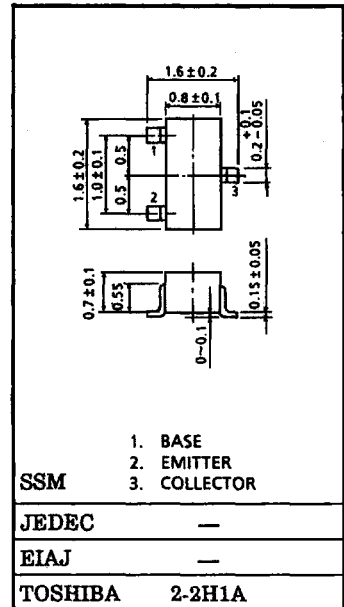

Weight : 2.4mg

MAXIMUM RATINGS (T<sub>a</sub> = 25°C)

CHARACTERISTIC	SYMBOL	RATING	UNIT	
Collector-Base Voltage	RN1114~1118	V <sub>CB0</sub>	50	V
Collector-Emitter Voltage		V <sub>CE0</sub>	50	V
Emitter-Base Voltage	RN1114	V <sub>EB0</sub>	5	V
	RN1115		6	
	RN1116		7	
	RN1117		15	
	RN1118		25	
Collector Current	RN1114~1118	I <sub>C</sub>	100	mA
Collector Power Dissipation		P <sub>C</sub>	100	mW
Junction Temperature		T <sub>j</sub>	150	°C
Storage Temperature Range		T <sub>stg</sub>	-55~150	°C

# RN1114, 1115, 1116 RN1117, 1118

(RN1114)

ELECTRICAL CHARACTERISTICS (Ta = 25°C)

CHARACTERISTIC		SYMBOL	TEST CONDITION	MIN.	TYP.	MAX.	UNIT
Collector Cut-off Current	RN1114~1118	$I_{CBO}$	$V_{CB}=50V, I_E=0$	—	—	100	nA
	RN1114~1118	$I_{CEO}$	$V_{CE}=50V, I_B=0$	—	—	500	nA
Emitter Cut-off Current	RN1114	$I_{EBO}$	$V_{EB}=5V, I_C=0$	0.35	—	0.65	mA
	RN1115		$V_{EB}=6V, I_C=0$	0.37	—	0.71	
	RN1116		$V_{EB}=7V, I_C=0$	0.36	—	0.68	
	RN1117		$V_{EB}=15V, I_C=0$	0.78	—	1.46	
	RN1118		$V_{EB}=25V, I_C=0$	0.33	—	0.63	
DC Current Gain	RN1114~16, 18	$h_{FE}$	$V_{CE}=5V, I_C=10mA$	50	—	—	
	RN1117			30	—	—	
Collector-Emitter Saturation Voltage	RN1114~1118	$V_{CE(sat)}$	$I_C=5mA, I_B=0.25mA$	—	0.1	0.3	V
Input Voltage (ON)	RN1114	$V_I(ON)$	$V_{CE}=0.2V, I_C=5mA$	0.6	—	2.0	V
	RN1115			0.7	—	2.5	
	RN1116			0.8	—	2.5	
	RN1117			1.5	—	3.5	
	RN1118			2.5	—	10.0	
Input Voltage (OFF)	RN1114	$V_I(OFF)$	$V_{CE}=5V, I_C=0.1mA$	0.3	—	0.9	V
	RN1115			0.3	—	1.0	
	RN1116			0.3	—	1.1	
	RN1117			0.3	—	2.3	
	RN1118			0.5	—	5.7	
Transition Frequency	RN1114~1118	$f_T$	$V_{CE}=10V, I_C=5mA$	—	250	—	MHz
Collector Output Capacitance	RN1114~1118	$C_{ob}$	$V_{CB}=10V, I_E=0, f=1MHz$	—	3.0	6.0	pF
Input Resistor	RN1114	$R_1$	—	0.7	1.0	1.3	k $\Omega$
	RN1115			1.54	2.2	2.86	
	RN1116			3.29	4.7	6.11	
	RN1117			7.0	10.0	13.0	
	RN1118			32.9	47.0	61.1	
Resistor Ratio	RN1114	$R_1/R_2$	—	—	0.1	—	
	RN1115			—	0.22	—	
	RN1116			—	0.47	—	
	RN1117			—	2.13	—	
	RN1118			—	4.7	—	

# RN1114, 1115, 1116 RN1117, 1118

(RN1114)

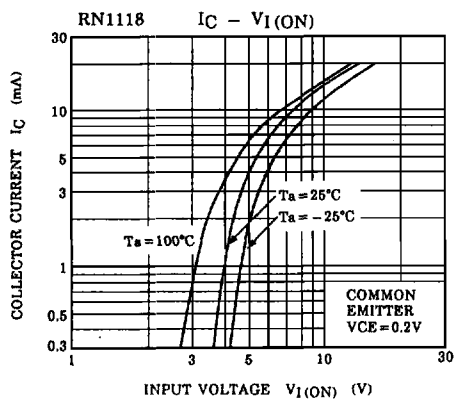
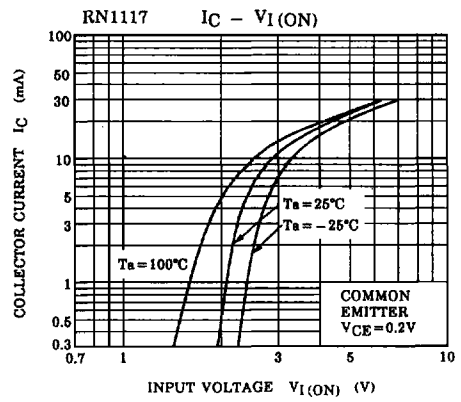
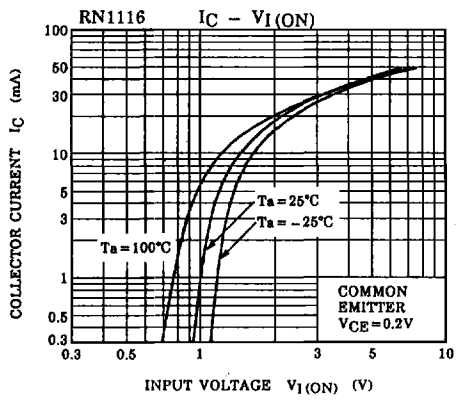
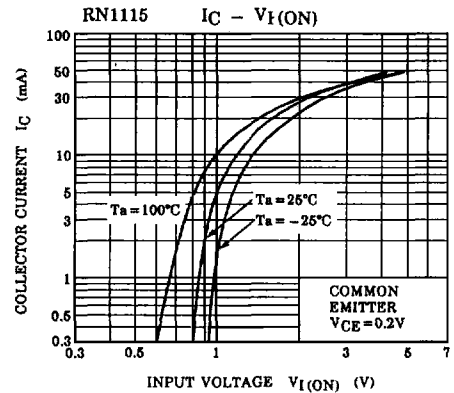
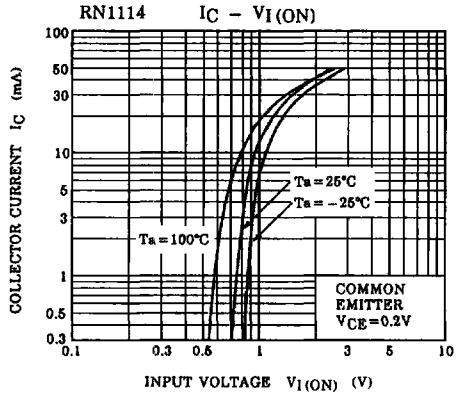

# RN1114, 1115, 1116 RN1117, 1118

(RN1114)

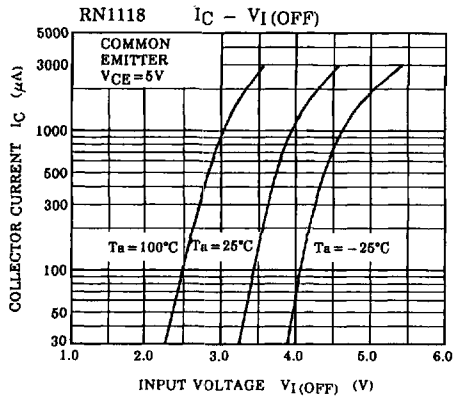
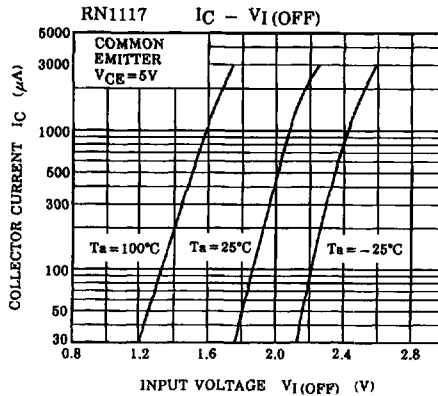
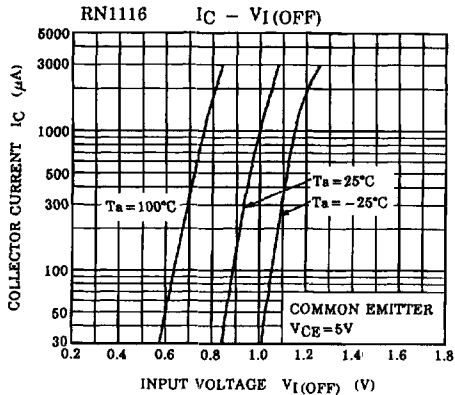
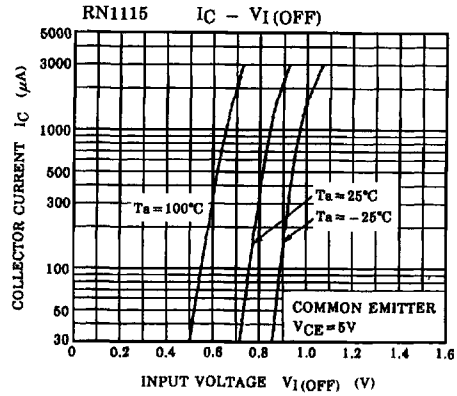
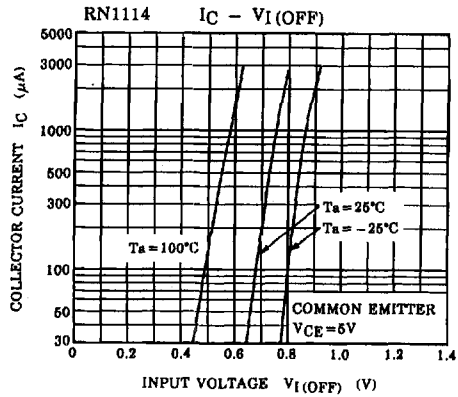

# RN1114, 1115, 1116 RN1117, 1118

(RN1114)

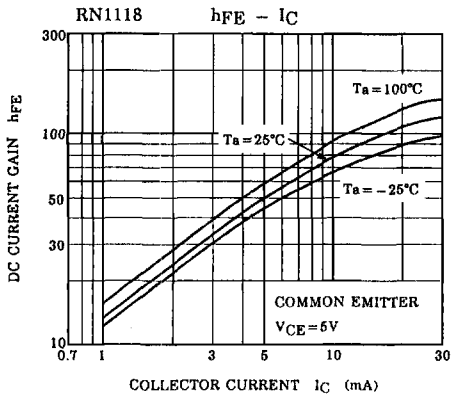
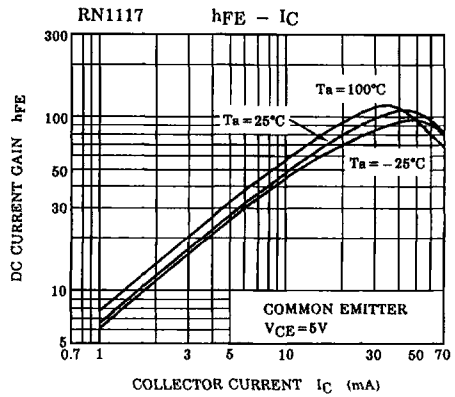
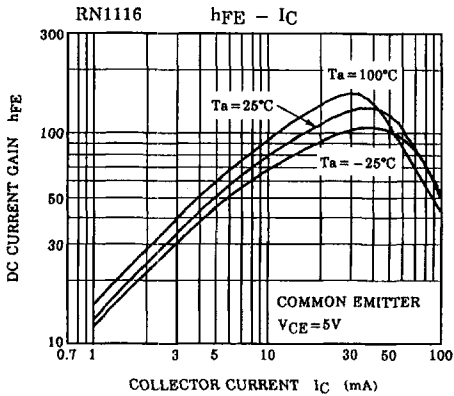
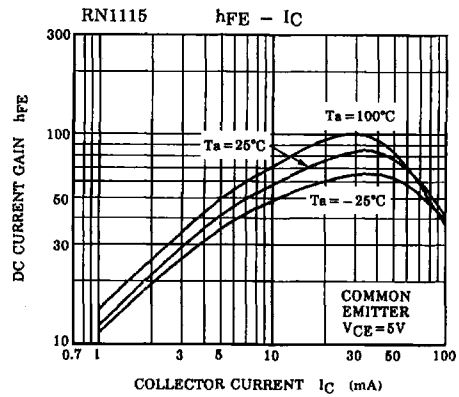
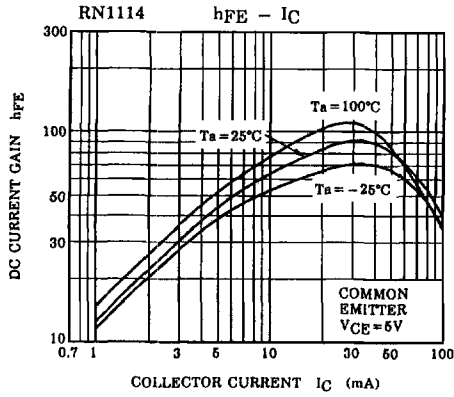

# RN1114, 1115, 1116 RN1117, 1118

(RN1114)

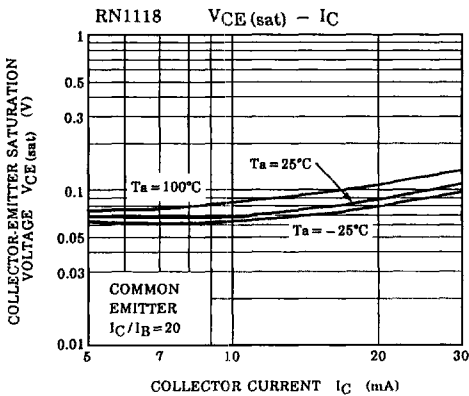
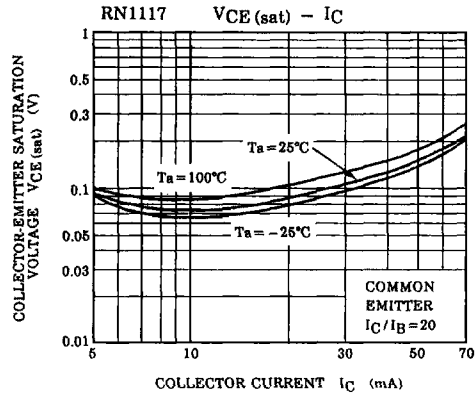
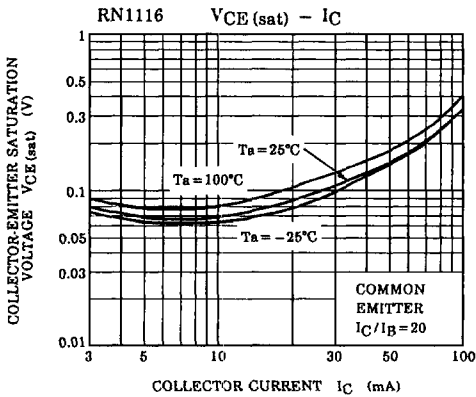
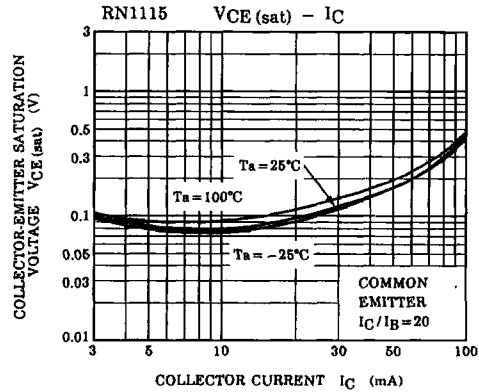
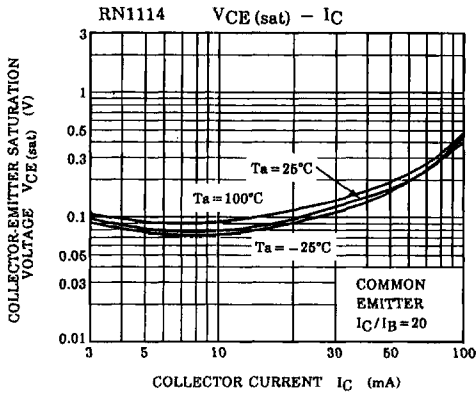

**RN1114, 1115, 1116  
RN1117, 1118**

(RN1114)

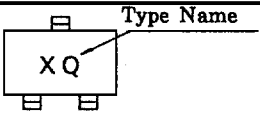
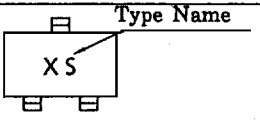
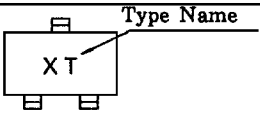
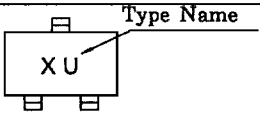
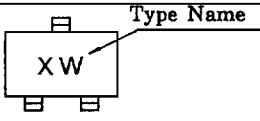
TYPE NAME	MARKING
RN1114	 <p>The diagram shows a rectangular box containing the letters 'XQ'. Above the box is a small square symbol. To the right of the box, the text 'Type Name' is written above a horizontal line. An arrow points from the 'Type Name' text to the top-right corner of the box. Below the box are two small square symbols.</p>
RN1115	 <p>The diagram shows a rectangular box containing the letters 'XS'. Above the box is a small square symbol. To the right of the box, the text 'Type Name' is written above a horizontal line. An arrow points from the 'Type Name' text to the top-right corner of the box. Below the box are two small square symbols.</p>
RN1116	 <p>The diagram shows a rectangular box containing the letters 'XT'. Above the box is a small square symbol. To the right of the box, the text 'Type Name' is written above a horizontal line. An arrow points from the 'Type Name' text to the top-right corner of the box. Below the box are two small square symbols.</p>
RN1117	 <p>The diagram shows a rectangular box containing the letters 'XU'. Above the box is a small square symbol. To the right of the box, the text 'Type Name' is written above a horizontal line. An arrow points from the 'Type Name' text to the top-right corner of the box. Below the box are two small square symbols.</p>
RN1118	 <p>The diagram shows a rectangular box containing the letters 'XW'. Above the box is a small square symbol. To the right of the box, the text 'Type Name' is written above a horizontal line. An arrow points from the 'Type Name' text to the top-right corner of the box. Below the box are two small square symbols.</p>