

## Rochester Electronics Manufactured Components

Rochester branded components are manufactured using either die/wafers purchased from the original suppliers or Rochester wafers recreated from the original IP. All recreations are done with the approval of the OCM.

Parts are tested using original factory test programs or Rochester developed test solutions to guarantee product meets or exceed the OCM data sheet.

## Quality Overview

- ISO-9001
- AS9120 certification
- Qualified Manufacturers List (QML) MIL-PRF-35835
  - Class Q Military
  - Class V Space Level
- Qualified Suppliers List of Distributors (QSLD)
  - Rochester is a critical supplier to DLA and meets all industry and DLA standards.

Rochester Electronics, LLC is committed to supplying products that satisfy customer expectations for quality and are equal to those originally supplied by industry manufacturers.

The original manufacturer's datasheet accompanying this document reflects the performance and specifications of the Rochester manufactured version of this device. Rochester Electronics guarantees the performance of its semiconductor products to the original OEM specifications. 'Typical' values are for reference purposes only. Certain minimum or maximum ratings may be based on product characterization, design, simulation, or sample testing.



## 54LS253/DM54LS253/DM74LS253 TRI-STATE® Data Selectors/Multiplexers

### General Description

Each of these Schottky-clamped data selectors/multiplexers contains inverters and drivers to supply fully complementary, on-chip, binary decoding data selection to the AND-OR gates. Separate output control inputs are provided for each of the two four-line sections.

The TRI-STATE outputs can interface directly with data lines of bus-organized systems. With all but one of the common outputs disabled (at a high impedance state), the low impedance of the single enabled output will drive the bus line to a high or low logic level.

### Features

- TRI-STATE version of LS153 with same pinout
- Schottky-diode-clamped transistors
- Permit multiplexing from N-lines to one line
- Performs parallel-to-serial conversion
- Strobe/output control
- High fanout totem-pole outputs
- Typical propagation delay
  - Data to output 12 ns
  - Select to output 21 ns
- Typical power dissipation 35 mW
- Alternate Military/Aerospace device (54LS253) is available. Contact a National Semiconductor Sales Office/Distributor for specifications.

### Connection Diagram

Dual-In-Line Package

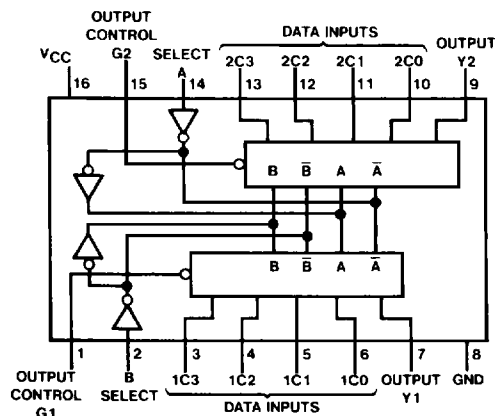

TL/F/6416-1

Order Number 54LS253DMQB, 54LS253FMQB,  
54LS253LMQB, DM54LS253J, DM54LS253W,  
DM74LS253M or DM74LS253N  
See NS Package Number E20A, J16A,  
M16A, N16E or W16A

### Function Table

Select Inputs		Data Inputs				Output Control	Output
B	A	C0	C1	C2	C3	G	Y
X	X	X	X	X	X	H	Z
L	L	L	X	X	X	L	L
L	L	H	X	X	X	L	H
L	H	X	L	X	X	L	L
L	H	X	H	X	X	L	H
H	L	X	X	L	X	L	L
H	L	X	X	H	X	L	H
H	H	X	X	X	L	L	L
H	H	X	X	X	H	L	H

Address Inputs A and B are common to both sections.

H = High Level, L = Low Level, X = Don't Care, Z = High Impedance (off).

**Absolute Maximum Ratings** (Note)

If Military/Aerospace specified devices are required, please contact the National Semiconductor Sales Office/Distributors for availability and specifications.

Supply Voltage	7V
Input Voltage	7V
Operating Free Air Temperature Range	
DM54LS and 54LS	-55°C to +125°C
DM74LS	0°C to +70°C
Storage Temperature Range	-65°C to +150°C

Note: The "Absolute Maximum Ratings" are those values beyond which the safety of the device cannot be guaranteed. The device should not be operated at these limits. The parametric values defined in the "Electrical Characteristics" table are not guaranteed at the absolute maximum ratings. The "Recommended Operating Conditions" table will define the conditions for actual device operation.

**Recommended Operating Conditions**

Symbol	Parameter	DM54LS253			DM74LS253			Units
		Min	Nom	Max	Min	Nom	Max	
V <sub>CC</sub>	Supply Voltage	4.5	5	5.5	4.75	5	5.25	V
V <sub>IH</sub>	High Level Input Voltage	2			2			V
V <sub>IL</sub>	Low Level Input Voltage			0.7			0.8	V
I <sub>OH</sub>	High Level Output Current			-1			-2.6	mA
I <sub>OL</sub>	Low Level Output Current			12			24	mA
T <sub>A</sub>	Free Air Operating Temperature	-55		125	0		70	°C

**Electrical Characteristics** over recommended operating free air temperature range (unless otherwise noted)

Symbol	Parameter	Conditions	Min	Typ (Note 1)	Max	Units
V <sub>I</sub>	Input Clamp Voltage	V <sub>CC</sub> = Min, I <sub>I</sub> = -18 mA			-1.5	V
V <sub>OH</sub>	High Level Output Voltage	V <sub>CC</sub> = Min, I <sub>OH</sub> = Max V <sub>IL</sub> = Max, V <sub>IH</sub> = Min	DM54	2.4	3.4	V
			DM74	2.4	3.1	
V <sub>OL</sub>	Low Level Output Voltage	V <sub>CC</sub> = Min, I <sub>OL</sub> = Max V <sub>IL</sub> = Max, V <sub>IH</sub> = Min	DM54		0.4	V
			DM74		0.5	
			DM74		0.4	
I <sub>I</sub>	Input Current @ Max Input Voltage	V <sub>CC</sub> = Max, V <sub>I</sub> = 7V			0.1	mA
I <sub>IH</sub>	High Level Input Current	V <sub>CC</sub> = Max, V <sub>I</sub> = 2.7V			20	μA
I <sub>IL</sub>	Low Level Input Current	V <sub>CC</sub> = Max, V <sub>I</sub> = 0.4V			-0.4	mA
I <sub>OZH</sub>	Off-State Output Current with High Level Output Voltage Applied	V <sub>CC</sub> = Max, V <sub>O</sub> = 2.7V V <sub>IH</sub> = Min, V <sub>IL</sub> = Max			20	μA
I <sub>OZL</sub>	Off-State Output Current with Low Level Output Voltage Applied	V <sub>CC</sub> = Max, V <sub>O</sub> = 0.4 V <sub>IH</sub> = Min, V <sub>IL</sub> = Max			-20	μA
I <sub>OS</sub>	Short Circuit Output Current	V <sub>CC</sub> = Max (Note 2)	DM54	-20	-100	mA
			DM74	-20	-100	
I <sub>CC1</sub>	Supply Current	V <sub>CC</sub> = Max (Note 3)		7	12	mA
I <sub>CC2</sub>	Supply Current	V <sub>CC</sub> = Max (Note 4)		8.5	14	mA

Note 1: All typicals are at V<sub>CC</sub> = 5V, T<sub>A</sub> = 25°C.

Note 2: Not more than one output should be shorted at a time, and the duration should not exceed one second.

Note 3: I<sub>CC1</sub> is measured with all outputs open, and all the inputs grounded.

Note 4: I<sub>CC2</sub> is measured with the outputs open, OUTPUT CONTROL at 4.5V and all other inputs grounded.

## Switching Characteristics at $V_{CC} = 5V$ and $T_A = 25^\circ C$ (See Section 1 for Test Waveforms and Output Load)

Symbol	Parameter	From (Input) To (Output)	$R_L = 667\Omega$				Units
			$C_L = 45\text{ pF}$		$C_L = 150\text{ pF}$		
			Min	Max	Min	Max	
$t_{PLH}$	Propagation Delay Time Low to High Level Output	Data to Y		25		35	ns
$t_{PHL}$	Propagation Delay Time High to Low Level Output	Data to Y		20		30	ns
$t_{PLH}$	Propagation Delay Time Low to High Level Output	Select to Y		45		54	ns
$t_{PHL}$	Propagation Delay Time High to Low Level Output	Select to Y		32		44	ns
$t_{PZH}$	Output Enable Time to High Level Output	Output Control to Y		18		32	ns
$t_{PZL}$	Output Enable Time to Low Level Output	Output Control to Y		23		35	ns
$t_{PHZ}$	Output Disable Time from High Level Output (Note 1)	Output Control to Y		41			ns
$t_{PLZ}$	Output Disable Time from Low Level Output (Note 1)	Output Control to Y		27			ns

Note 1:  $C_L = 5\text{ pF}$ .

## Logic Diagram

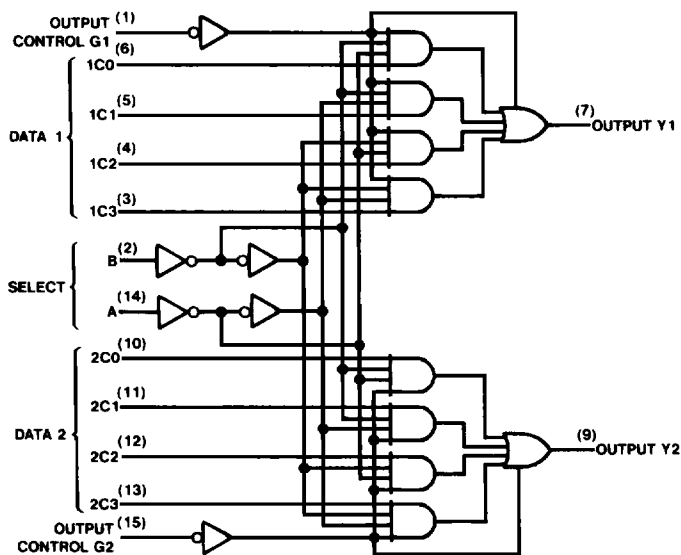

TL/F/6416-2