



Product Description

RF2389 is a high performance InGaP HBT MMIC amplifier utilizing a Darlington configuration. The part is designed to run from a 5V supply, does not require a dropping resistor, and is stable over a wide temperature range. RF2389 is designed for high linearity and low noise CATV applications. It is internally matched to 75Ω but can also be used in 50Ω systems. It is offered in a small SOT-89 package and is RoHS compliant.

Features

- Flat Gain Response: 16.5dB ±0.4dB
- Noise Figure:
 - 2.7dB typ (48MHz to 1002MHz)
 - 2.8dB typ (5MHz to 200MHz)
- Very Low Distortion:
 - 79/-88/-94dBc: CSO/CTB/XMOD
- Single Fixed 5V Supply
- Robust 1000V ESD, Class 1C
-

Applications

- Broadband CATV Gain Block
- CATV Distribution Amplifiers
- Pre-Amplifier for CATV Multi-Dwelling Units
- General Purpose 50Ω Applications
- Return Path (Upstream) Amplification
- Return Path (Upstream) Laser Driver

Optimum Technology Matching® Applied

- GaAs HBT
- GaAs MESFET
- InGaP HBT
- SiGe BiCMOS
- Si BiCMOS
- SiGe HBT
- GaAs pHEMT
- Si CMOS
- Si BJT
- GaN HEMT
- InP HBT
- RF MEMS
- LDMOS

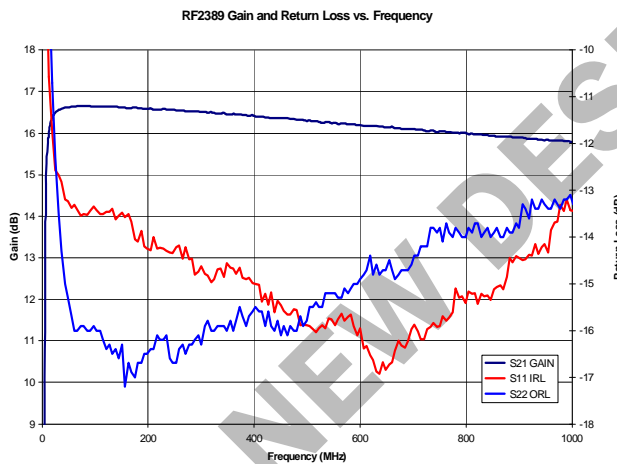

Parameter	Specification			Unit	Condition
	Min.	Typ.	Max.		
Electrical Characteristics (50Ω)					
Small Signal Gain		16.5		dB	500MHz
Gain Flatness		±0.4		dB	50MHz to 1000MHz
Output Power at 1dB Compression		19.5		dBm	500MHz
Third Order Intercept Point		38.5		dBm	500MHz
Second Order Intercept Point		57.5		dBm	500MHz
Input Return Loss		16		dB	50MHz to 1000MHz
Output Return Loss		14		dB	50MHz to 1000MHz
Reverse Isolation		19		dB	50MHz to 1000MHz
Noise Figure		2.7		dB	500MHz
Device Operating Voltage		5		V	
Device Operating Current		110		mA	
Thermal Resistance		48.8		°C/W	junction - lead

Test Conditions: V_P=5V, I_P=110mA Typ., T_L=25°C. OIP₃, OIP₂ Tone Spacing=6MHz, P_{OUT} per tone=0dBm. Tested with App Circuit.

Absolute Maximum Ratings

Parameter	Rating	Unit
Supply Voltage (V_{CC})	-0 to +6	VDC
RF Input Power	+10	dBm
Operating Lead Temperature (T_L)	-40 to +85	°C
Storage Temperature Range	-40 to +150	°C

Operation of this device beyond any one of these limits may cause permanent damage. For reliable continuous operation, the device voltage and current must not exceed the maximum operating values specified in the table on page one.

Bias Conditions should also satisfy the following expression:

$$I_D V_D < (T_J - T_L) / R_{TH, J-L}$$

If $V_{CC} > 5V$ is used, a derated dropping resistor should be used to supply V_{CC} of 5V to pin 3.



Caution! ESD sensitive device.

Exceeding any one or a combination of the Absolute Maximum Rating conditions may cause permanent damage to the device. Extended application of Absolute Maximum Rating conditions to the device may reduce device reliability. Specified typical performance or functional operation of the device under Absolute Maximum Rating conditions is not implied.

RoHS status based on EU Directive 2002/95/EC (at time of this document revision).

The information in this publication is believed to be accurate and reliable. However, no responsibility is assumed by RF Micro Devices, Inc. ("RFMD") for its use, nor for any infringement of patents, or other rights of third parties, resulting from its use. No license is granted by implication or otherwise under any patent or patent rights of RFMD. RFMD reserves the right to change component circuitry, recommended application circuitry and specifications at any time without prior notice.

Parameter	Specification			Unit	Condition
	Min.	Typ.	Max.		
Electrical Characteristics (75Ω)					
Small Signal Gain		16.3		dB	500MHz
Gain Flatness		±0.4		dB	50MHz to 500MHz
Output Power at 1dB Compression		18.5		dBm	500MHz
Third Order Intercept Point		36		dBm	500MHz
Second Order Intercept Point		53		dBm	500MHz
CSO		-65		dBc	77Ch., Flat Tilt, 25dBmV Out
CTB		-88		dBc	77Ch., Flat Tilt, 25dBmV Out
XMOD		-94		dBc	77Ch., Flat Tilt, 25dBmV Out
Input Return Loss		14		dB	50MHz to 1000MHz
Output Return Loss		15		dB	50MHz to 1000MHz
Reverse Isolation		20		dB	50MHz to 1000MHz
Noise Figure		3.0		dB	500MHz
Device Operating Voltage		5		V	
Device Operating Current		110		mA	
Thermal Resistance		48.8		°C/W	junction - lead

Test Conditions: $V_P = 5V$, $I_P = 110mA$ Typ., $T_L = 25°C$. OIP₃, OIP₂ Tone Spacing=6MHz, P_{OUT} per tone=0dBm. Tested with App Circuit.

Parameter	Specification			Unit	Condition
	Min.	Typ.	Max.		
Electrical Characteristics (50 or 75Ω)					
Small Signal Gain		16.5		dB	5MHz to 200MHz
Gain Flatness		±0.25		dB	5MHz to 200MHz
CSO		-63		dBc	Seven (7) channels, NTSC frequency raster: T7-T13 (7.0MHz to 43.0MHz, +50dBmV flat output level, per channel)
CTB		-70		dBc	Seven (7) channels, NTSC frequency raster: T7-T13 (7.0MHz to 43.0MHz, +50dBmV flat output level, per channel)
Input Return Loss		16		dB	5MHz to 200MHz
Output Return Loss		17.5		dB	5MHz to 200MHz
Reverse Isolation		14		dB	5MHz to 200MHz
Noise Figure		2.8		dB	5MHz to 200MHz
Device Operating Voltage		5		Vdc	
Device Operating Current		110		mA	

Test Conditions: $V_P = 5V$, $I_P = 110mA$ Typ., $T = +25°C$; tested with 5MHz to 200MHz application circuit.

Typical Performance Curves (75Ω)

Input Return Loss

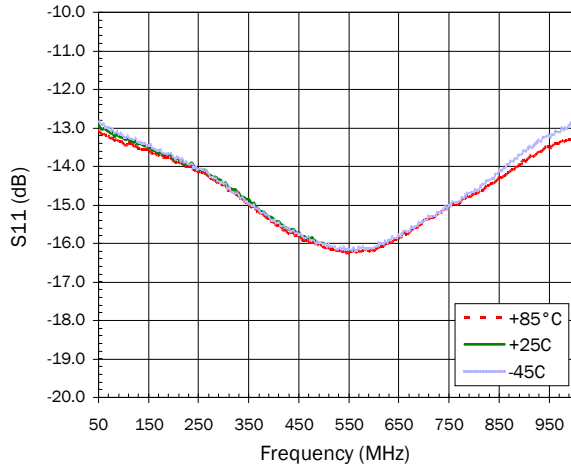

Output Return Loss

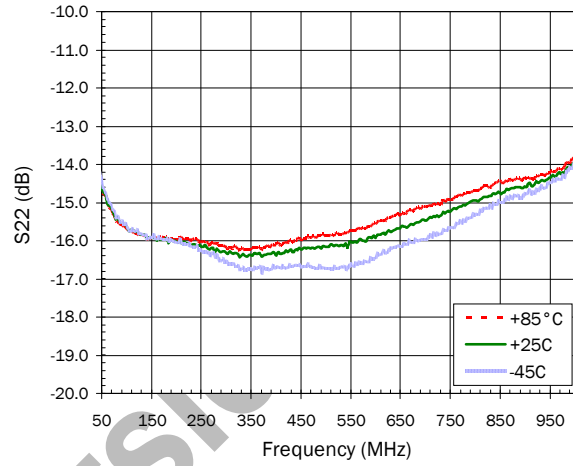

Reverse Isolation

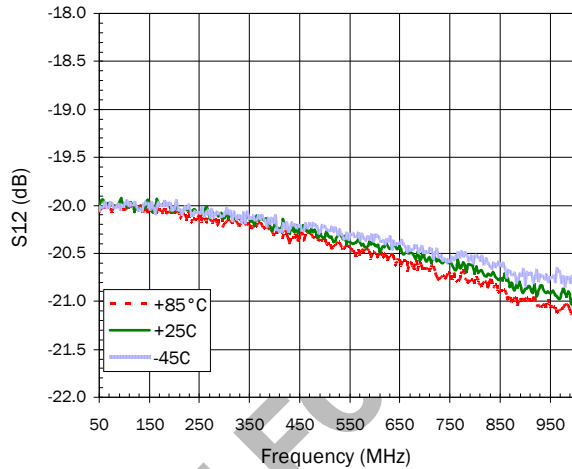

Gain

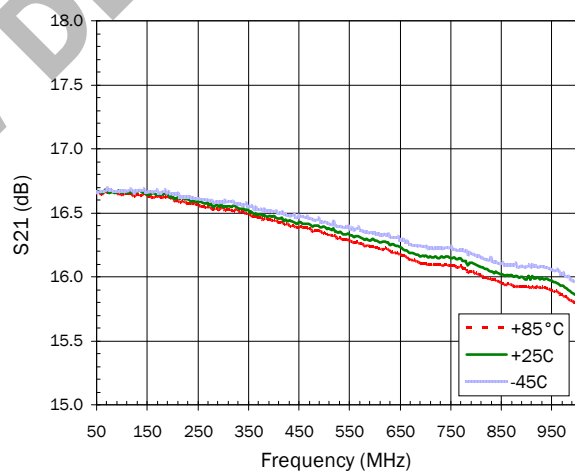

NOT FOR PRODUCTION DESIGN

Typical Performance Curves (75Ω)

OIP₃ dBm

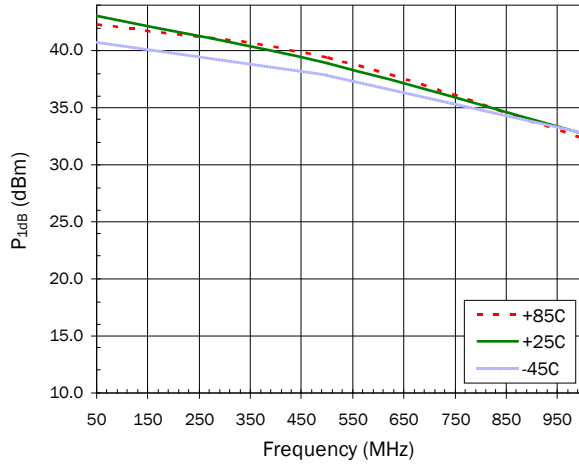

OIP₂ dBm

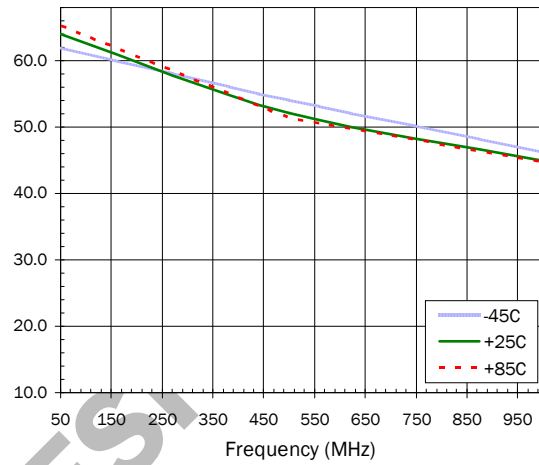

P_{1dB}

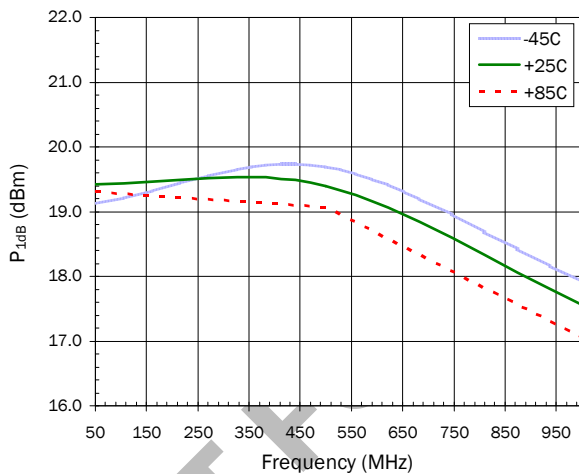

Noise Figure

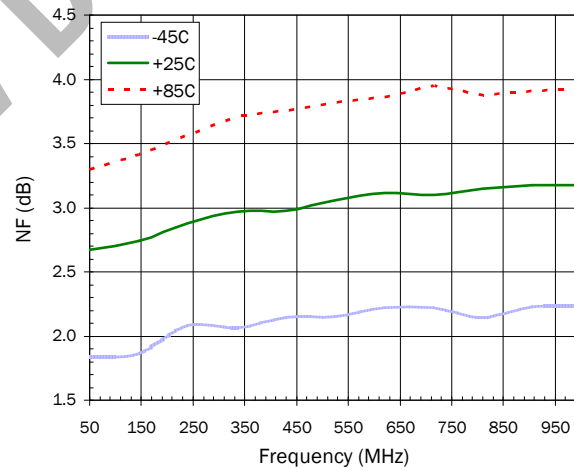

NOT FOR DESIGN

Typical Performance Curves (75Ω)

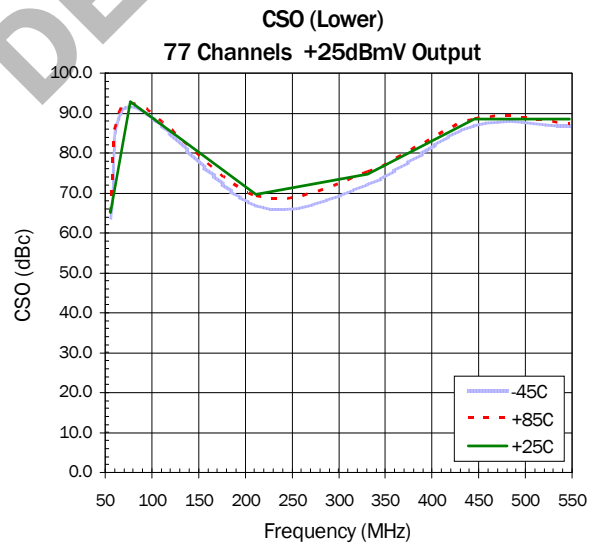
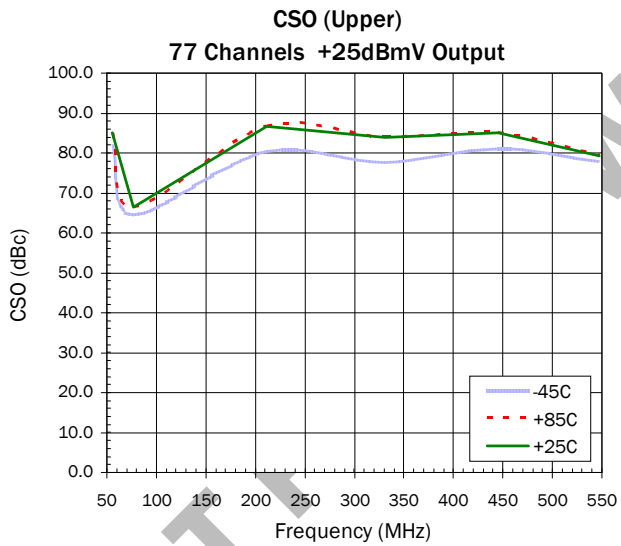
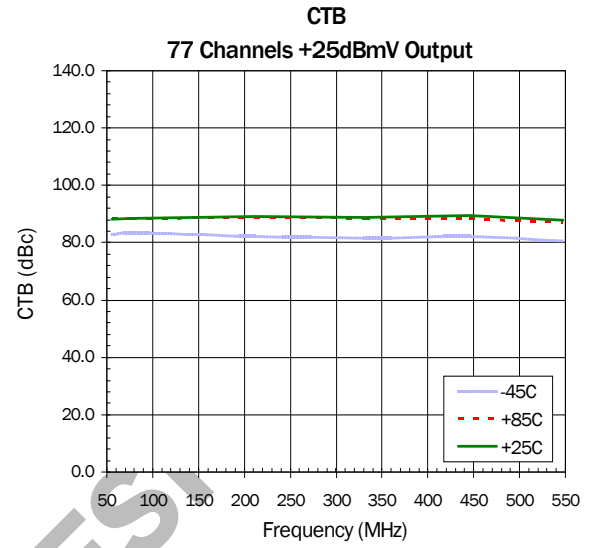
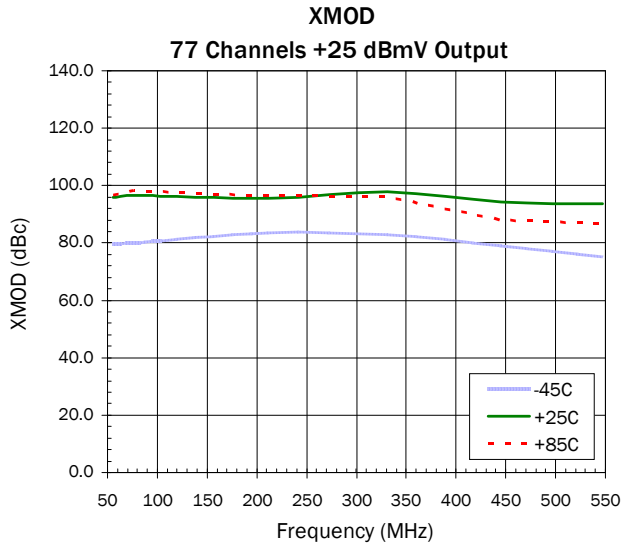

Typical Performance Curves (50Ω)

Input Return Loss

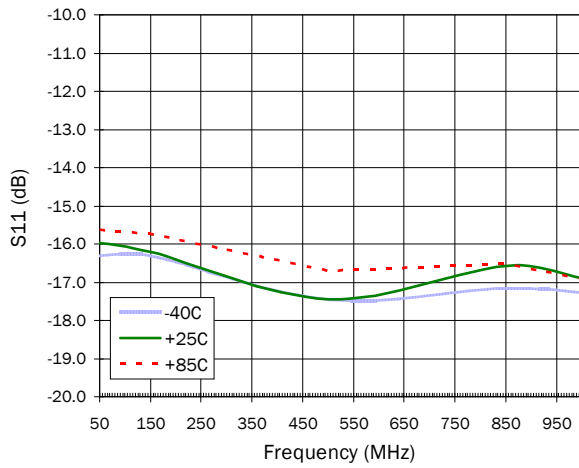

Gain

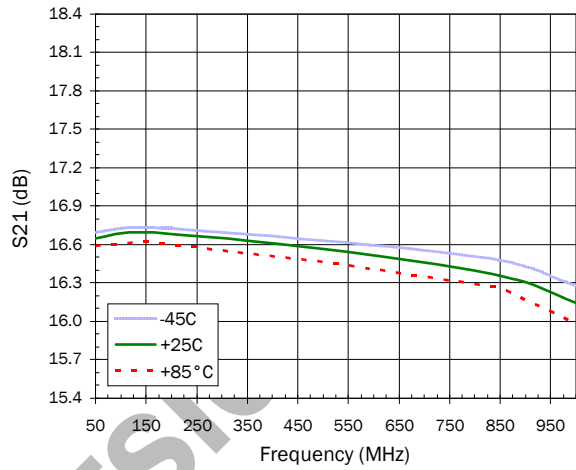

Reverse Isolation

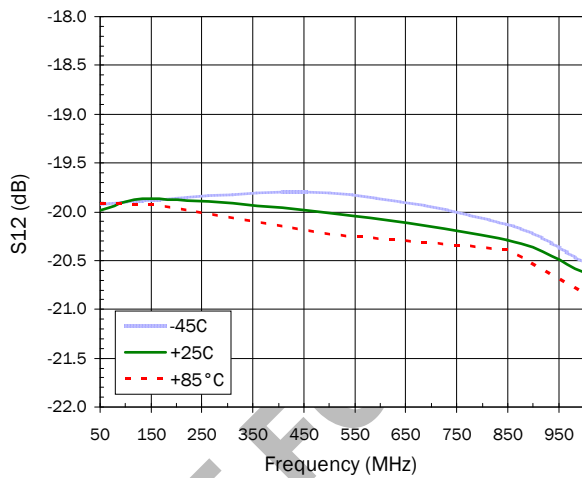

Output Return Loss

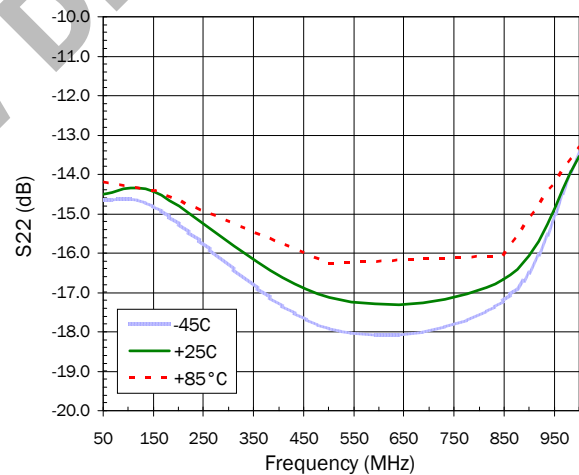

NOT FOR NEW DESIGN

Typical Performance Curves (50Ω)

P_{1dB}

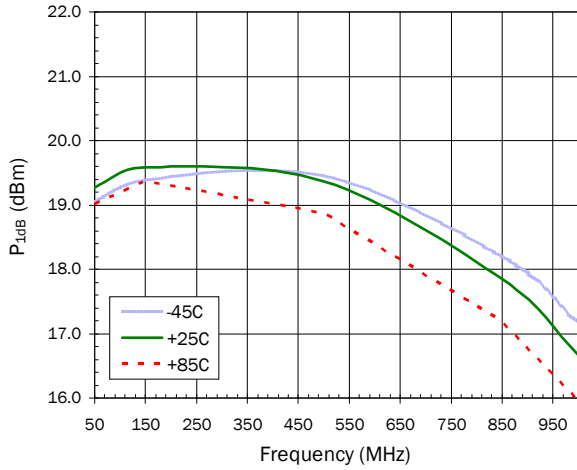

Noise Figure

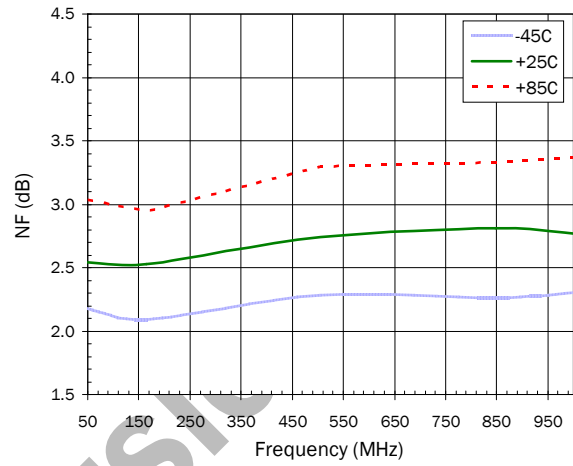

OIP₃ dBm

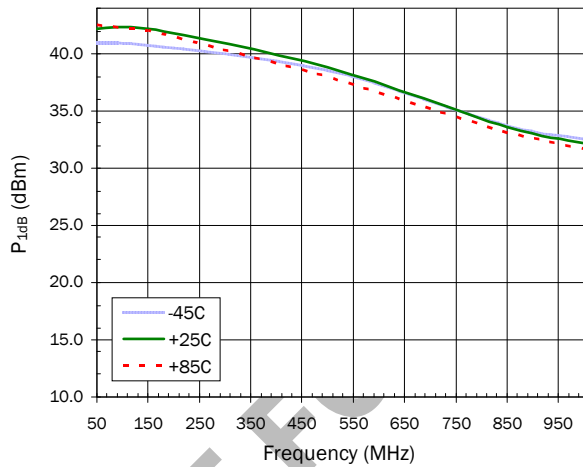

OIP₂ dBm

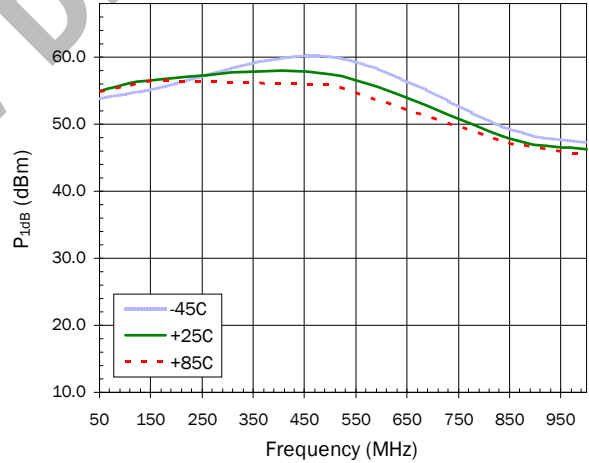

NOT FOR DESIGN

Application Schematic (50Ω and 75Ω)

Frequency 50MHz to 1000MHz

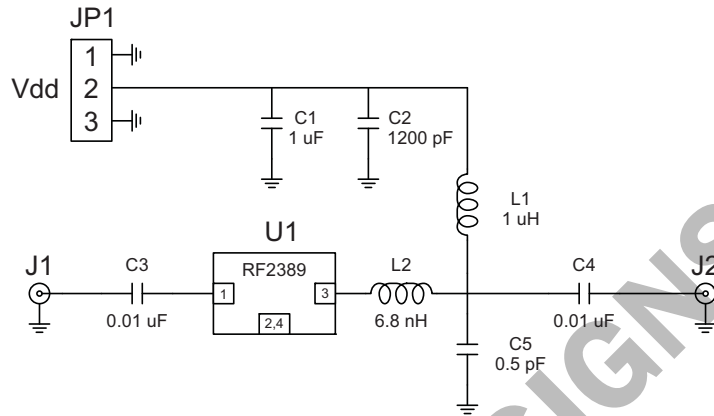

Frequency 5 MHz to 200 MHz

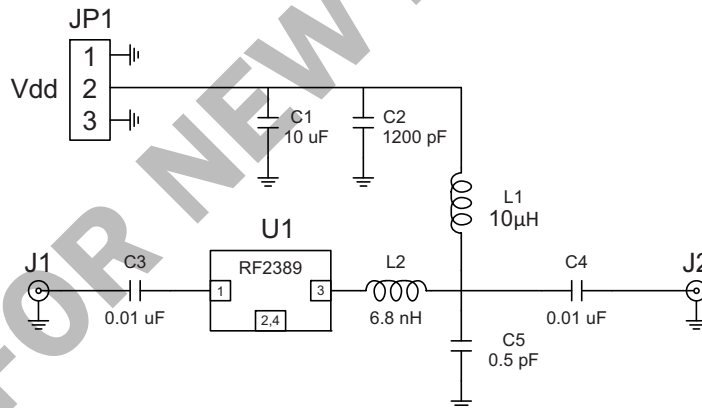

Application Circuit Element Values

Reference Designator	Description	
	48MHz to 1002MHz Application	48MHz to 1002MHz Application
J1, J2	Hielind Electronics (SMA)/Trompeter Electronics (COAX-F)	
C1	1uF Panasonic	
C3, C4	10000pF Panasonic	
C2	1200 pF Panasonic	
C5	0.5pF Panasonic	
L1	1.0uH LS Coilcraft	10 uH LS Coilcraft
L2	6.8nH Toko	

Evaluation Board Layout (75Ω)

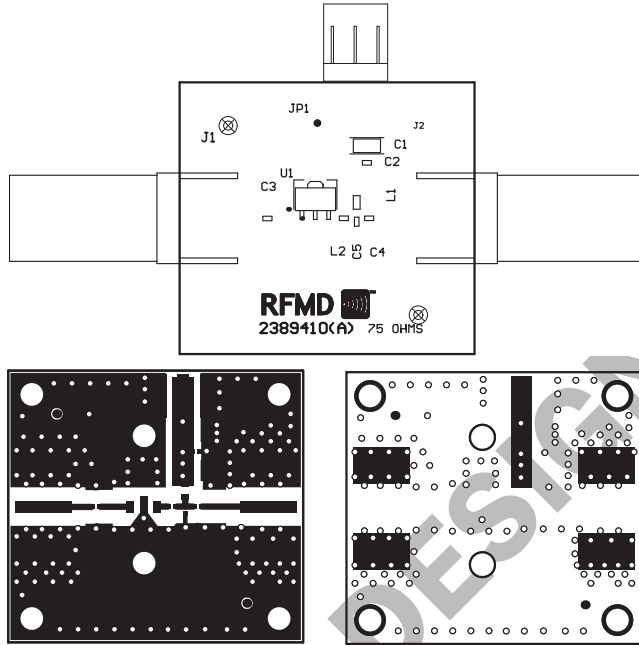

Evaluation Board Layout (50Ω)

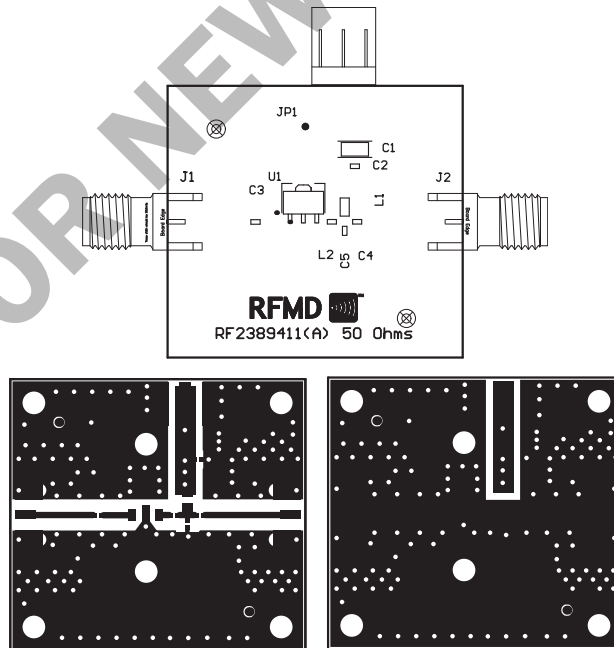

Suggested PCB Pad Layout

Dimensions in inches (millimeters)

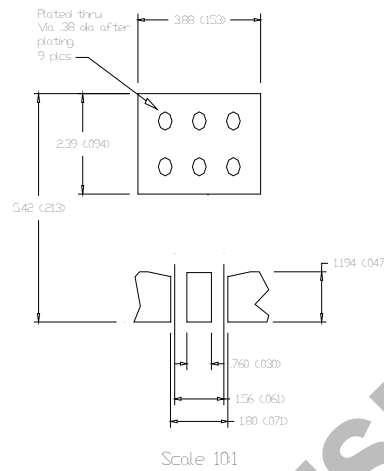

Generic Land Pattern. This land pattern is applicable to both backside patterns shown.

Package Drawing

Dimensions in inches (millimeters)

Refer to drawing posted at www.rfmd.com for tolerances.

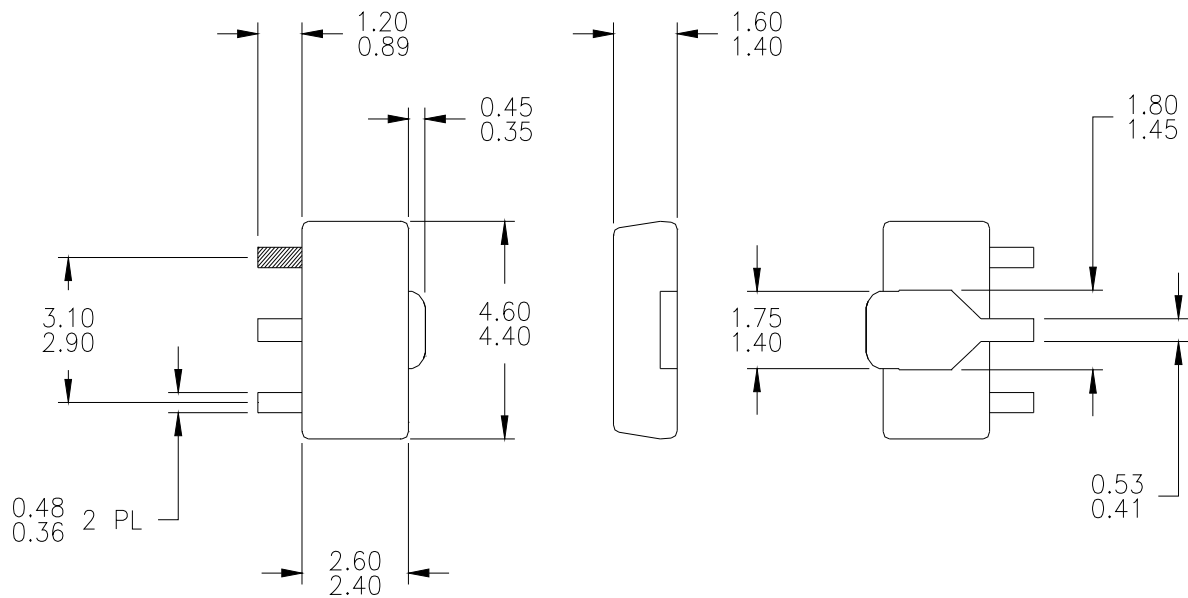

NOTE: SHADED LEAD IS PIN 1

Package Marking

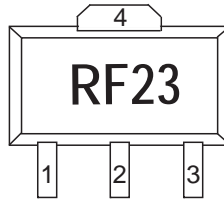

Pin-out Assignments

Pin	Function	Description
1	RFIN	RF input pin. This pin requires the use of an external DC-blocking capacitor chosen for the frequency of operation.
2, 4	GND	Connection to ground. Use via holes for best performance to reduce lead inductance as close to ground leads as possible.
3	RFOUT/BIAS	RF output and bias pin. DC-voltage is present on this pin, therefore a DC-blocking capacitor is necessary for proper operation.

Ordering Information

Part Number	Description
RF2389	25 pc Sample Bag
RF2389SB	5 pc Sample Bag
RF2389TR7	750 pc Tape and Reel
RF2389TR13	2500 pc Tape and Reel
RF2389PCK-410	RF2389 75Ω Evaluation Board and 5 pc Sample Bag
RF2389PCK-411	RF2389 50Ω Evaluation Board and 5 pc Sample Bag

NOT FOR NEW DESIGNS

NOT FOR NEW DESIGNS