

DM74LS14 Hex Inverters with Schmitt Trigger Inputs

General Description

This device contains six independent gates each of which performs the logic INVERT function. Each input has hysteresis

which increases the noise immunity and transforms a slowly changing input signal to a fast changing, jitter free output.

Connection Diagram

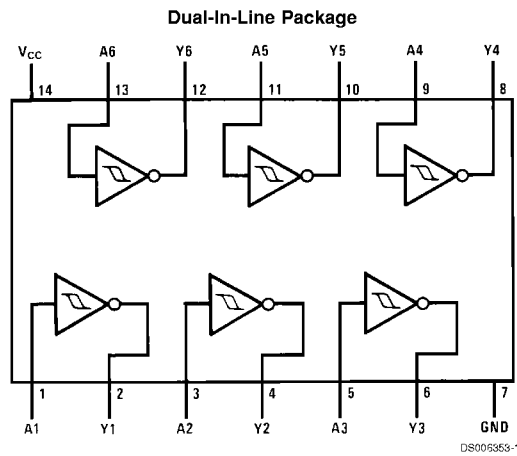

Order Number 54LS14DMQB, 54LS14FMQB,
54LS14LMQB, DM74LS14M or DM74LS14N
See Package Number E20A, J14A, M14A, N14A or W14B

Function Table

$$Y = \bar{A}$$

Input	Output
A	Y
L	H
H	L

H = High Logic Level
L = Low Logic Level

Absolute Maximum Ratings (Note 1)

Supply Voltage	7V	54LS	-55°C to +125°C
Input Voltage	7V	DM74LS	0°C to +70°C
Operating Free Air Temperature Range		Storage Temperature Range	-65°C to +150°C

Recommended Operating Conditions

Symbol	Parameter	54LS14			DM74LS14			Units
		Min	Nom	Max	Min	Nom	Max	
V _{CC}	Supply Voltage	4.5	5	5.5	4.75	5	5.25	V
V _{T+}	Positive-Going Input Threshold Voltage (Note 2)	1.5	1.6	2.0	1.4	1.6	1.9	V
V _{T-}	Negative-Going Input Threshold Voltage (Note 2)	0.6	0.8	1.1	0.5	0.8	1	V
HYS	Input Hysteresis (Note 2)	0.4	0.8		0.4	0.8		V
I _{OH}	High Level Output Current			-0.4			-0.4	mA
I _{OL}	Low Level Output Current			4			8	mA
T _A	Free Air Operating Temperature	-55		125	0		70	°C

Note 1: The "Absolute Maximum Ratings" are those values beyond which the safety of the device cannot be guaranteed. The device should not be operated at these limits. The parametric values defined in the "Electrical Characteristics" table are not guaranteed at the absolute maximum ratings. The "Recommended Operating Conditions" table will define the conditions for actual device operation.

Electrical Characteristics

over recommended operating free air temperature range (unless otherwise noted)

Symbol	Parameter	Conditions	Min	Typ (Note 3)	Max	Units
V _I	Input Clamp Voltage	V _{CC} = Min, I _I = -18 mA			-1.5	V
V _{OH}	High Level Output Voltage	V _{CC} = Min, I _{OH} = Max	54LS	2.5	3.4	V
		V _{IL} = Max	DM74	2.7	3.4	
V _{OL}	Low Level Output Voltage	V _{CC} = Min, I _{OL} = Max	54LS	0.25	0.4	V
		V _{IH} = Min	DM74	0.35	0.5	
		V _{CC} = Min, I _{OL} = 4 mA	DM74	0.25	0.4	
I _{T+}	Input Current at Positive-Going Threshold	V _{CC} = 5V, V _I = V _{T+}	DM74	-0.14		mA
I _{T-}	Input Current at Negative-Going Threshold	V _{CC} = 5V, V _I = V _{T-}	DM74	-0.18		mA
I _I	Input Current @ Max Input Voltage	V _{CC} = Max, V _I = 7V	DM74		0.1	mA
		V _{CC} = Max, V _I = 10.0V	54LS			
I _{IH}	High Level Input Current	V _{CC} = Max, V _I = 2.7V			20	µA
I _{IL}	Low Level Input Current	V _{CC} = Max, V _I = 0.4V			-0.4	mA
I _{OS}	Short Circuit Output Current	V _{CC} = Max	54LS	-20	-100	mA
		(Note 4)	DM74	-20	-100	
I _{CCH}	Supply Current with Outputs High	V _{CC} = Max		8.6	16	mA
I _{CCL}	Supply Current with Outputs Low	V _{CC} = Max		12	21	mA

Note 2: V_{CC} = 5V.

Note 3: All typicals are at V_{CC} = 5V, T_A = 25°C.

Note 4: Not more than one output should be shorted at a time, and the duration should not exceed one second.

Switching Characteristics

at $V_{CC} = 5V$ and $T_A = 25^\circ C$ (See for Test Waveforms and Output Load)

Symbol	Parameter	$R_L = 2\text{ k}\Omega$				Units
		$C_L = 15\text{ pF}$		$C_L = 50\text{ pF}$		
		Min	Max	Min	Max	
t_{PLH}	Propagation Delay Time Low to High Level Output	5	22	8	25	ns
t_{PHL}	Propagation Delay Time High to Low Level Output	5	22	10	33	ns

Physical Dimensions inches (millimeters) unless otherwise noted (Continued)

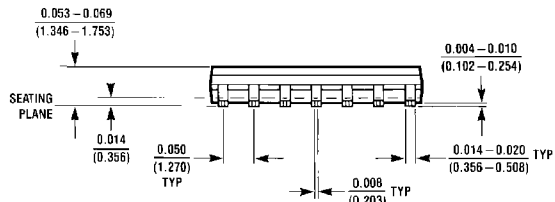
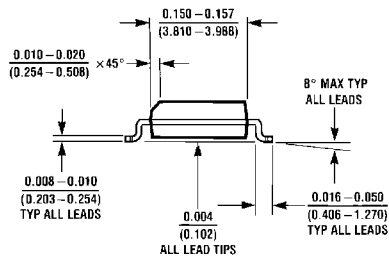
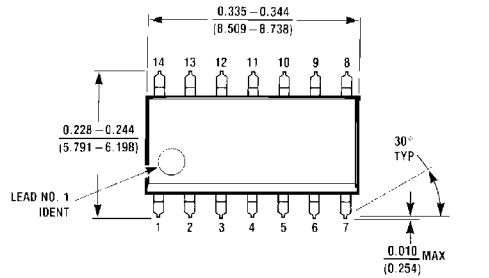

M14A (REV. H)

14-Lead Small Outline Molded Package (M)
Order Number DM74LS14M
Package Number M14A

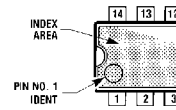
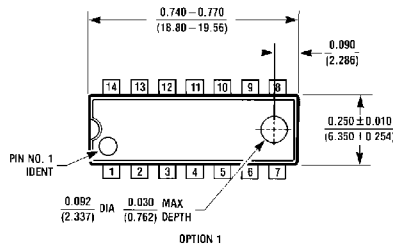

OPTION 1

OPTION 02

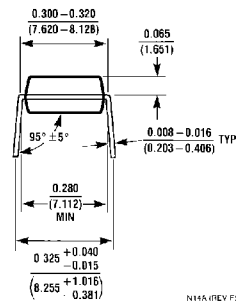
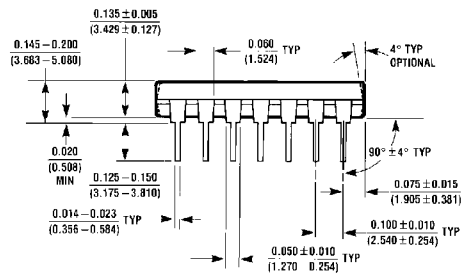

N14A (REV. F)

14-Lead Molded Dual-In-Line Package (N)
Order Number DM74LS14N
Package Number N14A

DM74LS14 Hex Inverters with Schmitt Trigger Inputs

Physical Dimensions inches (millimeters) unless otherwise noted (Continued)

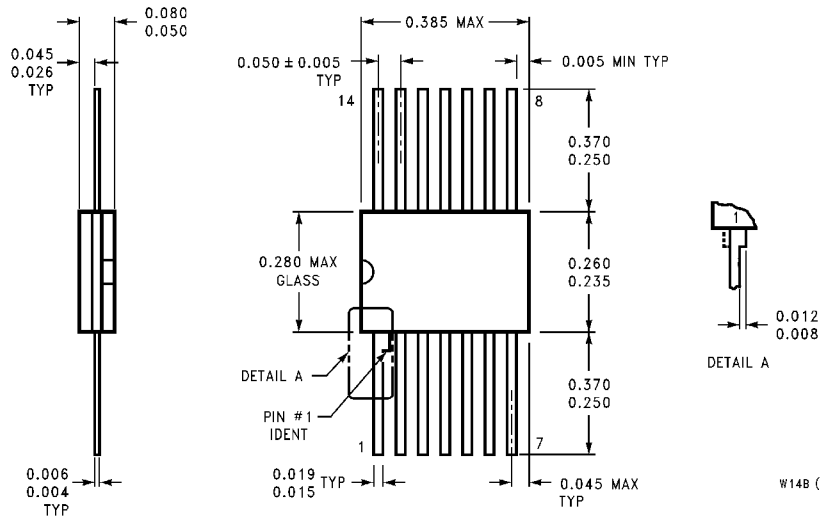

**14-Lead Ceramic Flat Package (W)
Order Number 54LS14FMQB
Package Number W14B**

W14B (REV J)

LIFE SUPPORT POLICY

FAIRCHILD'S PRODUCTS ARE NOT AUTHORIZED FOR USE AS CRITICAL COMPONENTS IN LIFE SUPPORT DEVICES OR SYSTEMS WITHOUT THE EXPRESS WRITTEN APPROVAL OF THE PRESIDENT OF FAIRCHILD SEMICONDUCTOR CORPORATION. As used herein:

1. Life support devices or systems are devices or systems which, (a) are intended for surgical implant into the body, or (b) support or sustain life, and (c) whose failure to perform when properly used in accordance with instructions for use provided in the labeling, can be reasonably expected to result in a significant injury to the user.
2. A critical component in any component of a life support device or system whose failure to perform can be reasonably expected to cause the failure of the life support device or system, or to affect its safety or effectiveness.

Fairchild Semiconductor Corporation Americas
Customer Response Center
Tel: 1-888-522-5372

Fairchild Semiconductor Europe
Fax: +49 (0) 1 80-530 85 86
Email: europe.support@nsc.com
Deutsch Tel: +49 (0) 8 141-35-0
English Tel: +44 (0) 1 793-85-68-56
Italy Tel: +39 (0) 2 57 5631

Fairchild Semiconductor Hong Kong Ltd.
13th Floor, Straight Block,
Ocean Centre, 5 Canton Rd.
Tsimshatsui, Kowloon
Hong Kong
Tel: +852 2737-7200
Fax: +852 2314-0061

National Semiconductor Japan Ltd.
Tel: 81-3-5620-6175
Fax: 81-3-5620-6179

www.fairchildsemi.com