

# DATA SHEET

For a complete data sheet, please also download:

- The IC06 74HC/HCT/HCU/HCMOS Logic Family Specifications
- The IC06 74HC/HCT/HCU/HCMOS Logic Package Information
- The IC06 74HC/HCT/HCU/HCMOS Logic Package Outlines

## **74HC/HCT139** Dual 2-to-4 line decoder/demultiplexer

Product specification  
File under Integrated Circuits, IC06

September 1993

## Dual 2-to-4 line decoder/demultiplexer

## 74HC/HCT139

## FEATURES

- Demultiplexing capability
- Two independent 2-to-4 decoders
- Multifunction capability
- Active LOW mutually exclusive outputs
- Output capability: standard
- I<sub>CC</sub> category: MSI

## GENERAL DESCRIPTION

The 74HC/HCT139 are high-speed Si-gate CMOS devices and are pin compatible with low power Schottky TTL (LSTTL). It is specified in compliance with JEDEC standard no. 7A.

The 74HC/HCT139 are high-speed, dual 2-to-4 line decoder/multiplexers. This device has two independent decoders, each accepting two binary weighted inputs ( $nA_0$  and  $nA_1$ ) and providing four mutually exclusive active LOW outputs ( $n\bar{Y}_0$  to  $n\bar{Y}_3$ ). Each decoder has an active LOW enable input ( $n\bar{E}$ ).

When  $n\bar{E}$  is HIGH, every output is forced HIGH. The enable can be used as the data input for a 1-to-4 demultiplexer application.

The "139" is identical to the HEF4556 of the HE4000B family.

## QUICK REFERENCE DATA

GND = 0 V; T<sub>amb</sub> = 25 °C; t<sub>r</sub> = t<sub>f</sub> = 6 ns

SYMBOL	PARAMETER	CONDITIONS	TYPICAL		UNIT
			HC	HCT	
t <sub>PHL</sub> / t <sub>PLH</sub>	propagation delay	C <sub>L</sub> = 15 pF; V <sub>CC</sub> = 5 V			
	nA <sub>n</sub> to n $\bar{Y}_n$		11	13	ns
	n $\bar{E}_3$ to n $\bar{Y}_n$		10	13	ns
C <sub>I</sub>	input capacitance		3.5	3.5	pF
C <sub>PD</sub>	power dissipation capacitance per multiplexer	notes 1 and 2	42	44	pF

## Notes

1. C<sub>PD</sub> is used to determine the dynamic power dissipation (P<sub>D</sub> in  $\mu$ W):

$$P_D = C_{PD} \times V_{CC}^2 \times f_i + \sum (C_L \times V_{CC}^2 \times f_o) \text{ where:}$$

f<sub>i</sub> = input frequency in MHz

f<sub>o</sub> = output frequency in MHz

$\sum (C_L \times V_{CC}^2 \times f_o)$  = sum of outputs

C<sub>L</sub> = output load capacitance in pF

V<sub>CC</sub> = supply voltage in V

2. For HC the condition is V<sub>I</sub> = GND to V<sub>CC</sub>  
For HCT the condition is V<sub>I</sub> = GND to V<sub>CC</sub> - 1.5 V

## APPLICATIONS

- Memory decoding or data-routing
- Code conversion

## ORDERING INFORMATION

See "74HC/HCT/HCU/HCMOS Logic Package Information".

# Dual 2-to-4 line decoder/demultiplexer

# 74HC/HCT139

## PIN DESCRIPTION

PIN NO.	SYMBOL	NAME AND FUNCTION
1, 15	$1\bar{E}, 2\bar{E}$	enable inputs (active LOW)
2, 3	$1A_0, 1A_1$	address inputs
4, 5, 6, 7	$1\bar{Y}_0$ to $1\bar{Y}_3$	outputs (active LOW)
8	GND	ground (0 V)
12, 11, 10, 9	$2\bar{Y}_0$ to $2\bar{Y}_3$	outputs (active LOW)
14, 13	$2A_0, 2A_1$	address inputs
16	$V_{CC}$	positive supply voltage

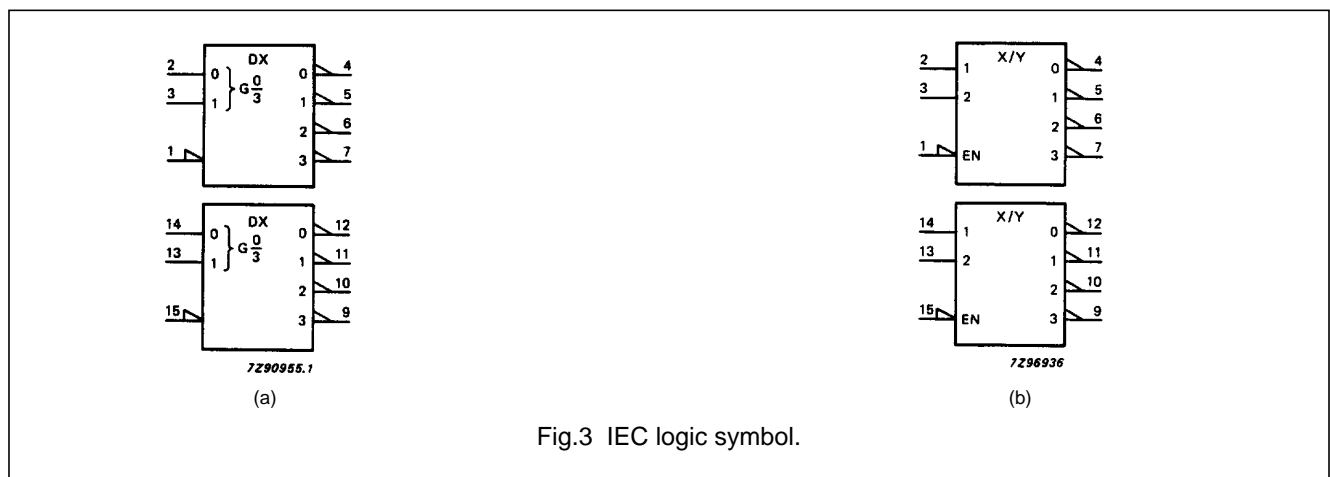
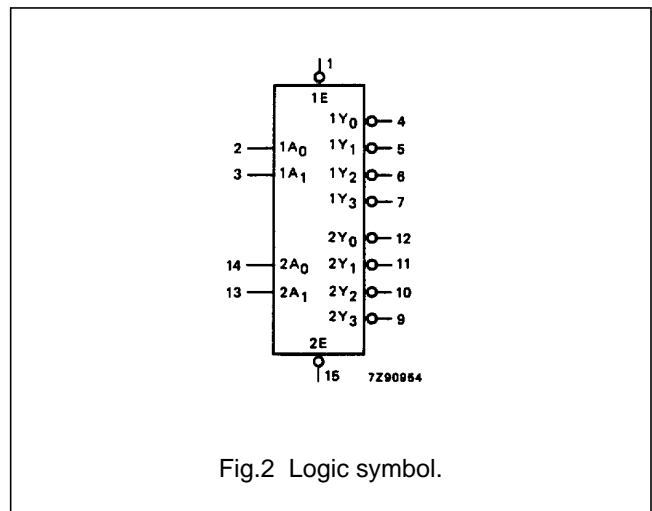
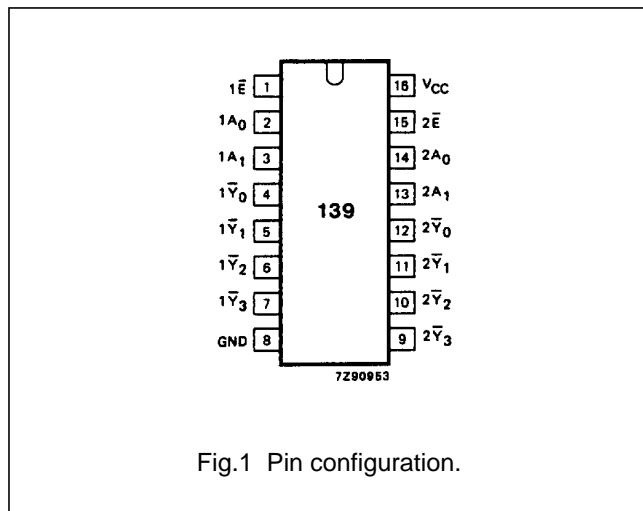

Dual 2-to-4 line decoder/demultiplexer

74HC/HCT139

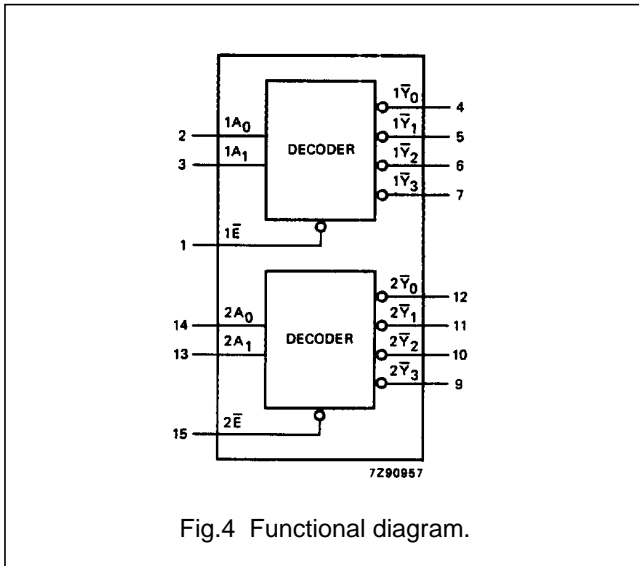

Fig.4 Functional diagram.

FUNCTION TABLE

INPUTS			OUTPUTS			
$n\bar{E}$	$nA_0$	$nA_1$	$n\bar{Y}_0$	$n\bar{Y}_1$	$n\bar{Y}_2$	$n\bar{Y}_3$
H	X	X	H	H	H	H
L	L	L	L	H	H	H
L	H	L	H	L	H	H
L	L	H	H	H	L	H
L	H	H	H	H	H	L

Notes

- H = HIGH voltage level  
L = LOW voltage level  
X = don't care

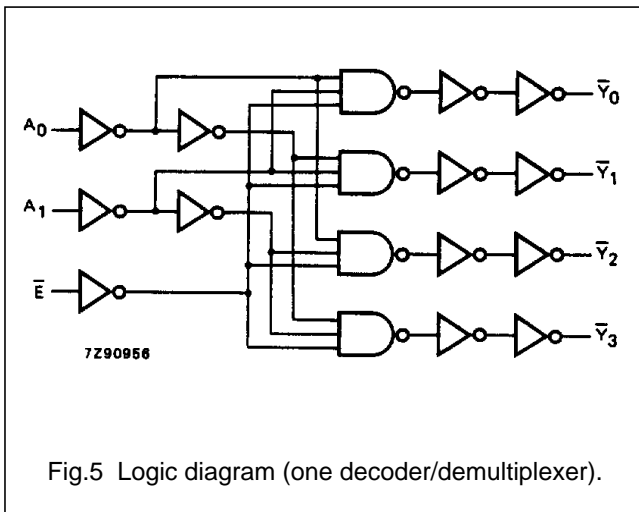

Fig.5 Logic diagram (one decoder/demultiplexer).

## Dual 2-to-4 line decoder/demultiplexer

## 74HC/HCT139

**DC CHARACTERISTICS FOR 74HC**

For the DC characteristics see *"74HC/HCT/HCU/HCMOS Logic Family Specifications"*.

Output capability: standard

I<sub>CC</sub> category: MSI

**AC CHARACTERISTICS FOR 74HC**

GND = 0 V; t<sub>r</sub> = t<sub>f</sub> = 6 ns; C<sub>L</sub> = 50 pF

SYMBOL	PARAMETER	T <sub>amb</sub> (°C)						UNIT	TEST CONDITIONS		
		74HC							V <sub>CC</sub> (V)	WAVEFORMS	
		+25			-40 to +85		-40 to +125				
		min.	typ.	max.	min.	max.	min.		max.		
t <sub>PHL</sub> / t <sub>PLH</sub>	propagation delay nA <sub>n</sub> to $\bar{Y}_n$		39 14 11	145 29 25		180 36 31		220 44 38	ns	2.0 4.5 6.0	Fig.6
t <sub>PHL</sub> / t <sub>PLH</sub>	propagation delay n $\bar{E}$ to n $\bar{Y}_n$		33 12 10	135 27 23		170 34 29		205 41 35	ns	2.0 4.5 6.0	Fig.7
t <sub>THL</sub> / t <sub>TLH</sub>	output transition time		19 7 6	75 15 13		95 19 16		110 22 19	ns	2.0 4.5 6.0	Figs 6 and 7

## Dual 2-to-4 line decoder/demultiplexer

## 74HC/HCT139

**DC CHARACTERISTICS FOR HCT**

For the DC characteristics see *"74HC/HCT/HCU/HCMOS Logic Family Specifications"*.

Output capability: standard

I<sub>CC</sub> category: MSI

**Note to HCT types**

The value of additional quiescent supply current ( $\Delta I_{CC}$ ) for a unit load of 1 is given in the family specifications. To determine  $\Delta I_{CC}$  per input, multiply this value by the unit load coefficient shown in the table below.

INPUT	UNIT LOAD COEFFICIENT
1A <sub>n</sub>	0.70
2A <sub>n</sub>	0.70
n $\bar{E}$	1.35

**AC CHARACTERISTICS FOR 74HCT**

GND = 0 V; t<sub>f</sub> = t<sub>r</sub> = 6 ns; C<sub>L</sub> = 50 pF

SYMBOL	PARAMETER	T <sub>amb</sub> (°C)								UNIT	TEST CONDITIONS	
		74HCT									V <sub>CC</sub> (V)	WAVEFORMS
		+25			-40 to +85		-40 to +125					
		min.	typ.	max.	min.	max.	min.	max.				
t <sub>PHL</sub> / t <sub>PLH</sub>	propagation delay nA <sub>n</sub> to $\bar{Y}_n$		16	34		43		51	ns	4.5	Fig.6	
t <sub>PHL</sub> / t <sub>PLH</sub>	propagation delay n $\bar{E}$ to n $\bar{Y}_n$		16	34		43		51	ns	4.5	Fig.7	
t <sub>THL</sub> / t <sub>TLH</sub>	output transition time		7	15		19		22	ns	4.5	Figs 6 and 7	

## Dual 2-to-4 line decoder/demultiplexer

74HC/HCT139

## AC WAVEFORMS

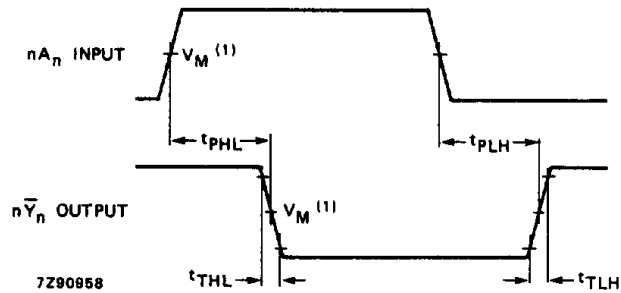

(1) HC :  $V_M = 50\%$ ;  $V_I = \text{GND to } V_{CC}$ .  
 HCT:  $V_M = 1.3 \text{ V}$ ;  $V_I = \text{GND to } 3 \text{ V}$ .

Fig.6 Waveforms showing the address input ( $nA_n$ ) to output ( $n\bar{Y}_n$ ) propagation delays and the output transition times.

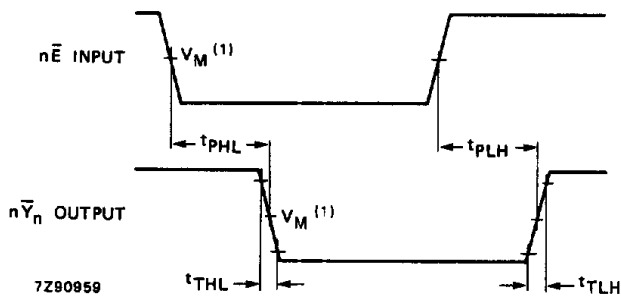

(1) HC :  $V_M = 50\%$ ;  $V_I = \text{GND to } V_{CC}$ .  
 HCT:  $V_M = 1.3 \text{ V}$ ;  $V_I = \text{GND to } 3 \text{ V}$ .

Fig.7 Waveforms showing the enable input ( $n\bar{E}$ ) to output ( $n\bar{Y}_n$ ) propagation delays and the output transition times.

## PACKAGE OUTLINES

See "74HC/HCT/HCU/HCMOS Logic Package Outlines".

# 74HC/HCT139; Dual 2-to-4 line decoder/demultiplexer

Information as of 2003-04-22

My.Semiconductors.COM.  
Your personal service from Philips Semiconductors.  
Please register now !

Use right mouse button to download datasheet

Download datasheet

Stay informed

Products

<input type="checkbox"/> General description	<input type="checkbox"/> Features	<input type="checkbox"/> Applications	<input type="checkbox"/> Datasheet
<input type="checkbox"/> Block diagram	<input type="checkbox"/> Buy online	<input type="checkbox"/> Support & tools	<input type="checkbox"/> Email/translate
<input type="checkbox"/> Products & packages	<input type="checkbox"/> Parametrics	<input type="checkbox"/> Similar products	<input type="checkbox"/>

[MultiMarket Semiconductors](#)

[Product Selector](#)

[Catalog by Function](#)

[Catalog by System](#)

[Cross-reference](#)

[Packages](#)

[End of Life information](#)

[Distributors Go Here!](#)

[Models](#)

[SoC solutions](#)

## General description

The 74HC/HCT139 are high-speed Si-gate CMOS devices and are pin compatible with low power Schottky TTL (LSTTL). It is specified in compliance with JEDEC standard no. 7A.

The 74HC/HCT139 are high-speed, dual 2-to-4 line decoder/multiplexers. This device has two independent decoders, each accepting two binary weighted inputs ( $nA_0$  and  $nA_1$ ) and providing four mutually exclusive active LOW outputs ( $nY_0$  to  $nY_3$ ). Each decoder has an active LOW enable input ( $nE$ ).

When  $nE$  is HIGH, every output is forced HIGH. The enable can be used as the data input for a 1-to-4 demultiplexer application.

The '139' is identical to the HEF4556 of the HE4000B family.

## Features

- Demultiplexing capability
- Two independent 2-to-4 decoders
- Multifunction capability
- Active LOW mutually exclusive outputs
- Output capability: standard
- $I_{CC}$  category: MSI

## Datasheet



Type number	Title	Publication release date	Datasheet status	Page count	File size (kB)	Datasheet
74HC/HCT139	Dual 2-to-4 line decoder/demultiplexer	9/1/1993	Product specification	7	44	<a href="#">Download</a>

## Additional datasheet info

To complete the device datasheet with package and family information, also download the following PDF files. The "Logic Package Information" document is required to determine in which package(s) this device is available.

Document	Description
----------	-------------



1	 <a href="#">HCT_FAMILY_SPECIFICATIONS</a>	HC/T Family Specifications, The IC06 74HC/HCT/HCMOS Logic Family Specifications
2	 <a href="#">HCT_PACKAGE_INFO</a>	HC/T Package Info, The IC06 74HC/HCT/HCMOS Logic Package Information
3	 <a href="#">HCT_PACKAGE_OUTLINES</a>	HC/T Package Outlines, The IC06 74HC/HCT/HCMOS Logic Package Outlines

## ▣ Parametrics

Type number	Package	Description	Propagation Delay(ns)	Voltage	No. of Pins	Power Dissipation Considerations	Logic Switching Levels	Output Drive Capability
74HC139D	<a href="#">SOT109</a> (SO16)	Dual 2-to-4 Line Decoder/Demultiplexer	15	5 Volts +	16	Low Power or Battery Applications	CMOS	Low
74HC139DB	<a href="#">SOT338-1</a> (SSOP16)	Dual 2-to-4 Line Decoder/Demultiplexer	15	5 Volts +	16	Low Power or Battery Applications	CMOS	Low
74HC139N	<a href="#">SOT38-1</a> (DIP16)	Dual 2-to-4 Line Decoder/Demultiplexer	15	5 Volts +	16	Low Power or Battery Applications	CMOS	Low
74HC139PW	<a href="#">SOT403-1</a> (TSSOP16)	Dual 2-to-4 Line Decoder/Demultiplexer	15	5 Volts +	16	Low Power or Battery Applications	CMOS	Low
74HCT139D	<a href="#">SOT109</a> (SO16)	Dual 2-to-4 Line Decoder/Demultiplexer; TTL Enabled	15	5 Volts +	16	Low Power or Battery Applications	TTL	Low
74HCT139DB	<a href="#">SOT338-1</a> (SSOP16)	Dual 2-to-4 Line Decoder/Demultiplexer; TTL Enabled	15	5 Volts +	16	Low Power or Battery Applications	TTL	Low
74HCT139N	<a href="#">SOT38-1</a> (DIP16)	Dual 2-to-4 Line Decoder/Demultiplexer; TTL Enabled	15	5 Volts +	16	Low Power or Battery Applications	TTL	Low
74HCT139PW	<a href="#">SOT403-1</a> (TSSOP16)	Dual 2-to-4 Line Decoder/Demultiplexer; TTL Enabled	15	5 Volts +	16	Low Power or Battery Applications	TTL	Low

## ▣ Products, packages, availability and ordering

Type number	<u>North American type number</u>	<u>Ordering code (12NC)</u>	<u>Marking/Packing</u>  <a href="#">Discretes packing info</a>	<u>Package</u>	<u>Device status</u>	<u>Buy online</u>
74HC139D	74HC139D	9337 135 00652	Standard Marking * Bulk Pack, CECC	<a href="#">SOT109</a> (SO16)	Full production	
	74HC139D-T	9337 135 00653	Standard Marking * Reel Pack, SMD, 13", CECC	<a href="#">SOT109</a> (SO16)	Full production	
74HC139DB	74HC139DB	9351 744 50112	Standard Marking * Bulk Pack	<a href="#">SOT338-1</a> (SSOP16)	Full production	
	74HC139DB-T	9351 744 50118	Standard Marking * Reel Pack, SMD, 13"	<a href="#">SOT338-1</a> (SSOP16)	Full production	

74HC139N	74HC139N	9336 693 00652	Standard Marking * Bulk Pack, CECC	<a href="#">SOT38-1</a> (DIP16)	Full production	<a href="#">order this</a> <input type="checkbox"/>
74HC139PW	74HC139PW	9351 744 30112	Standard Marking * Bulk Pack	<a href="#">SOT403-1</a> (TSSOP16)	Full production	<a href="#">order this</a> <input type="checkbox"/>
	74HC139PW-T	9351 744 30118	Standard Marking * Reel Pack, SMD, 13"	<a href="#">SOT403-1</a> (TSSOP16)	Full production	<a href="#">order this</a> <input type="checkbox"/>
74HCT139D	74HCT139D	9337 135 10652	Standard Marking * Bulk Pack, CECC	<a href="#">SOT109</a> (SO16)	Full production	<a href="#">order this</a> <input type="checkbox"/>
	74HCT139D-T	9337 135 10653	Standard Marking * Reel Pack, SMD, 13", CECC	<a href="#">SOT109</a> (SO16)	Full production	<a href="#">order this</a> <input type="checkbox"/>
74HCT139DB	74HCT139DB	9351 885 50112	Standard Marking * Bulk Pack	<a href="#">SOT338-1</a> (SSOP16)	Full production	<a href="#">order this</a> <input type="checkbox"/>
	74HCT139DB-T	9351 885 50118	Standard Marking * Reel Pack, SMD, 13"	<a href="#">SOT338-1</a> (SSOP16)	Full production	<a href="#">order this</a> <input type="checkbox"/>
74HCT139N	74HCT139N	9336 699 30652	Standard Marking * Bulk Pack, CECC	<a href="#">SOT38-1</a> (DIP16)	Full production	<a href="#">order this</a> <input type="checkbox"/>
74HCT139PW	74HCT139PW	9351 883 00112	Standard Marking * Bulk Pack	<a href="#">SOT403-1</a> (TSSOP16)	Full production	<a href="#">order this</a> <input type="checkbox"/>
	74HCT139PW-T	9351 883 00118	Standard Marking * Reel Pack, SMD, 13"	<a href="#">SOT403-1</a> (TSSOP16)	Full production	<a href="#">order this</a> <input type="checkbox"/>

Products in the above table are all in production. Some variants are discontinued; [click here](#) for information on these variants.

## Similar products

 [74HC/HCT139](#) links to the similar products page containing an overview of products that are similar in function or related to the type number(s) as listed on this page. The similar products page includes products from the same catalog tree(s), relevant selection guides and products from the same functional category.

## Support & tools

 [HC/T Family Specifications, The IC06 74HC/HCT/HCMOS Logic Family Specifications](#)(date 01-Mar-98)

 [HC/T User Guide](#)(date 01-Nov-97)

## Email/translate this product information

- [Email this product information.](#)
- Translate this product information page from English to:

The English language is the official language used at the [semiconductors.philips.com](#) website and webpages. All translations on this website are created through the use of [Google Language Tools](#) and are provided for convenience purposes only. No rights can be derived from any translation on this website.

| Copyright © 2003 Koninklijke Philips N.V. All rights reserved. | [Privacy Policy](#) |

| Koninklijke Philips N.V. | Access to and use of this Web Site is subject to the following [Terms of Use](#). |