

NOTES:

1. Ⓞ REPRESENTS A CRITICAL DIMENSION.
2. MAXIMUM PIN ROTATION: 2°.
3. MINIMUM PUSHOUT FORCE: 1 LB.
4. NOTE DELETED.
5. MINIMUM RETENTION FOR LOCKING CLIPS: 12 OZ.
6. MUST BE MEASURED AT BEND.
7. DUE TO THE HIGH AMOUNT OF INSERTION FORCE NEEDED, THE -LC OPTION IS NOT COMPATIBLE WITH AUTO PLACEMENT. SAMTEC RECOMMENDS MANUAL PLACEMENT FOR ALL ASSEMBLIES WITH THE -LC OPTION.

DO NOT SCALE FROM THIS PRINT

LTMM-1XX-XX-XX-D-XX-XX

No OF POSITIONS  
-02 THRU -25

POLARIZED OPTION  
XX INDICATES POS TO BE OMMITTED

TERMINAL STYLE  
-01: .100[2.54] POST HEIGHT (STANDARD)  
-02: .120[3.05] POST HEIGHT (SEE TABLE 1)

PLATING SPECIFICATION  
-G: 20μ" SELECTIVE GOLD IN CONTACT AREA, 3μ" SELECTIVE GOLD ON TAIL  
-T: MATTE TIN CONTACT AND TAIL  
-S: 30μ" SELECTIVE GOLD IN CONTACT AREA, MATTE TIN ON TAIL  
-L: 10μ" SELECTIVE GOLD IN CONTACT AREA, MATTE TIN ON TAIL  
-F: 3μ" SELECTIVE GOLD IN CONTACT AREA, MATTE TIN ON TAIL  
-H: 30μ" SELECTIVE GOLD IN CONTACT AREA, 3μ" SELECTIVE GOLD ON TAIL  
-SM: 30μ" SELECTIVE GOLD IN CONTACT AREA, MATTE TIN ON TAIL  
-TM: MATTE TIN ON ENTIRE PIN  
-LM: 15μ" SELECTIVE GOLD IN CONTACT AREA, MATTE TIN ON TAIL  
-FM: 3μ" SELECTIVE GOLD IN CONTACT AREA, MATTE TIN ON TAIL

OPTION  
LEAVE BLANK FOR THROUGH HOLE (SEE FIG 1 & TABLE 1)  
-RA: RIGHT ANGLE (SEE FIG 2, SHT 2 & TABLE 1)  
-SM: SURFACE MOUNT (SEE FIG 3, SHT 3 & TABLE 1)  
-LC: LOCKING CLIP (SEE NOTE 7) (USE LC-05-TM FOR TH STYLE, SEE FIG 1) (USE LC-07-TM FOR -SM STYLE, SEE FIG 3, SHT 3) (NOT AVAILABLE FOR -RA STYLE)  
-P: PICK & PLACE PAD (USE PPP-24, SEE FIG 4, SHT 2) (-SM OPTION ONLY) (ONLY AVAILABLE IN 04-25 POSITIONS)  
-M: METAL PICK AND PLACE PAD (USE MPP-07, SEE FIG 5, SHT 2) (-SM OPTION ONLY)  
-K: POLYIMIDE FILM (USE K-DOT-.295-.406-.005) (SEE FIG 6, SHT 3) (-SM OPTION ONLY)  
-TR: TAPE AND REEL (SEE FIG 7, SHT 4) (-SM OPTION ONLY)  
-D: DOUBLE (USE LTMM-XX-D-LC)

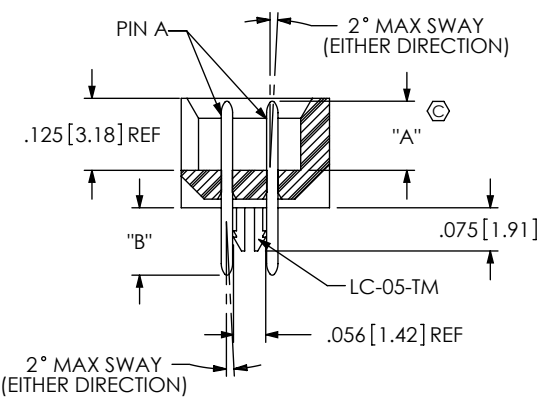
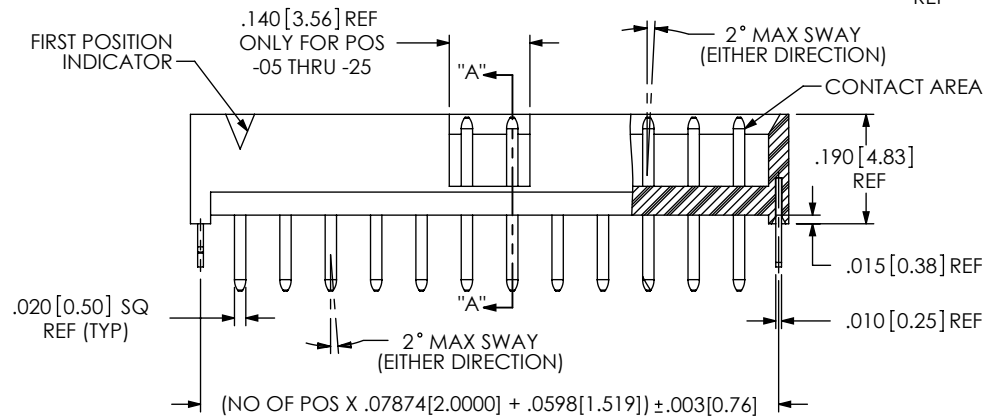
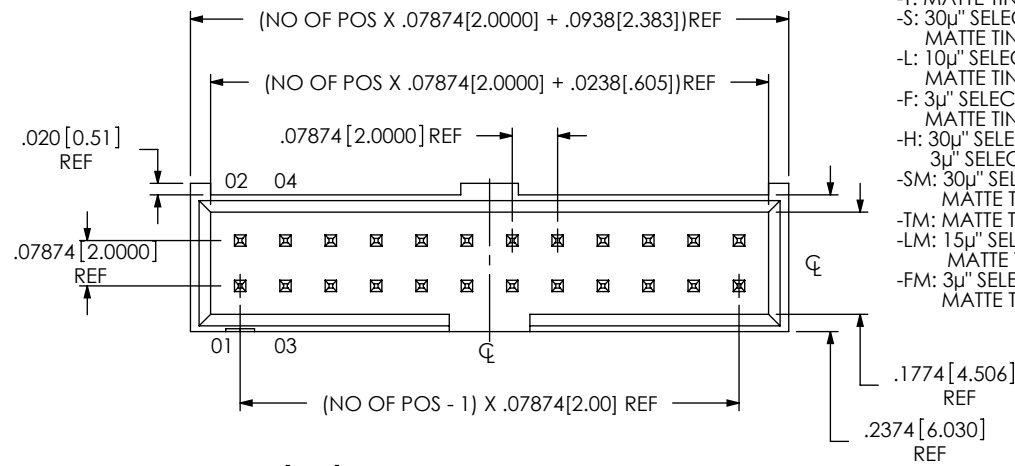

FIG 1 THROUGH HOLE LTMM-112-02-XX-D-LC SHOWN

SECTION "A"- "A"

THROUGH HOLE (SEE FIG 1)	LEAD STYLE	"A"	"B" REF	"C" REF	PIN A	PIN B
	-01	.100 [2.54]	.090 [2.30]	N/A	T-1S13-04-X-2	N/A
	-02	.120 [3.05]	.117 [3.00]	N/A	T-1S13-07-X-2	N/A
RIGHT ANGLE (SEE FIG 2, SHT 2)	-01	.100 [2.54]	.232 [5.90]	.390 [9.91]	T-1S13-05-X-2	T-1S13-06-X-2
	-02	.120 [3.05]	.228 [5.80]	.386 [9.80]	T-1S13-19-X-2	T-1S13-22-X-2
SURFACE MOUNT (SEE FIG 3, SHT 3)	-01	.100 [2.54]	.172 [4.40]	N/A	T-1S13-07-X-2	N/A
	-02	.120 [3.05]	.173 [4.40]	N/A	T-1S13-20-X-2	N/A

UNLESS OTHERWISE SPECIFIED, DIMENSIONS ARE IN INCHES. TOLERANCES ARE:  
DECIMALS ANGLES  
.XX: ±.01 [.3]  
.XXX: ±.005 [.13]  
.XXXX: ±.0020 [.051]

PROPRIETARY NOTE  
THIS DOCUMENT CONTAINS INFORMATION CONFIDENTIAL AND PROPRIETARY TO SAMTEC, INC. AND SHALL NOT BE REPRODUCED OR TRANSFERRED TO OTHER DOCUMENTS OR DISCLOSED TO OTHERS OR USED FOR ANY PURPOSE OTHER THAN THAT WHICH IT WAS OBTAINED WITHOUT THE EXPRESSED WRITTEN CONSENT OF SAMTEC, INC.



520 PARK EAST BLVD, NEW ALBANY, IN 47150  
PHONE: 812-944-6733 FAX: 812-948-5047  
e-Mail: info@SAMTEC.com code: 55322

MATERIAL: DO NOT SCALE DRAWING SHEET SCALE: 3:1  
INSULATOR: LCP, COLOR: BLACK  
TERMINAL: PHOSPHER BRONZE

DESCRIPTION: LTMM ASSEMBLY

DWG. NO. LTMM-1XX-XX-XX-D-XX-XX

BY: BRYANT 05/28/1992 SHEET 1 OF 4

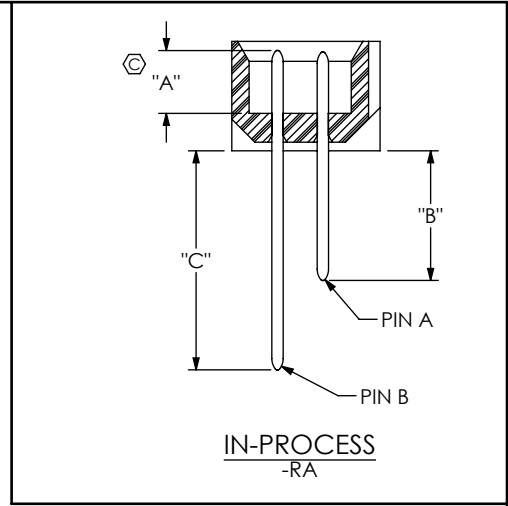
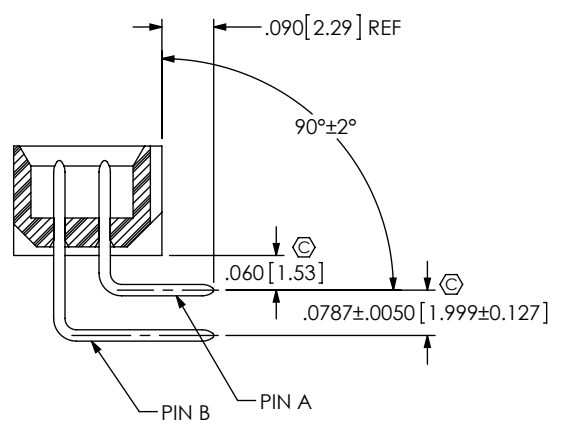
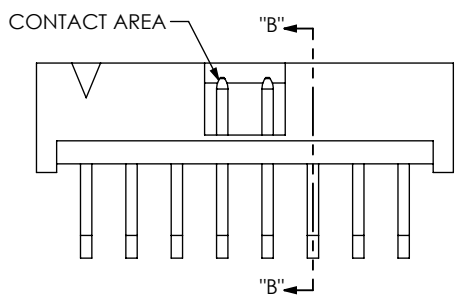
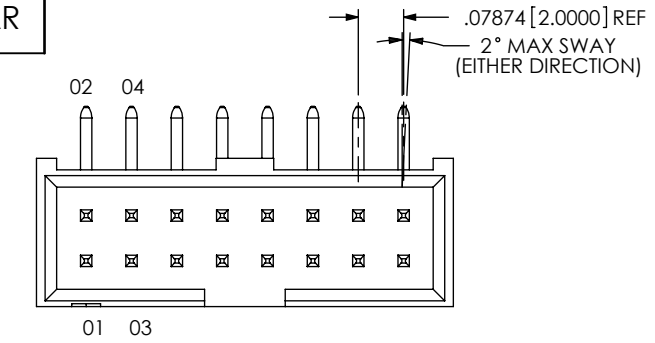

FIG 2  
RIGHT ANGLE  
LTMM-108-01-XX-D-RA SHOWN  
(DIFFERENT AS SHOWN, OTHERWISE SAME AS FIG 1)

SECTION "B"-"B"

NOTE: "R" = USED MEASURED DIMENSION  
"S" = {"R"-.250 [6.35]} / 2 ±.020 [0.51]

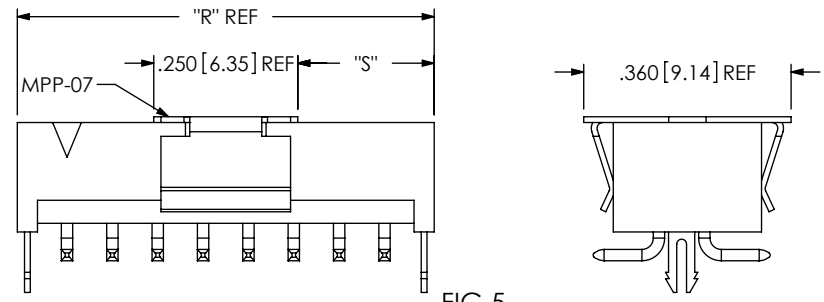

FIG 5  
-M: METAL PICK AND PLACE PAD  
LTMM-108-01-XX-D-SM-LC-M SHOWN  
FOR SURFACE MOUNT OPTIONS ONLY  
(DIFFERENT AS SHOWN, OTHERWISE SAME AS FIG 3)

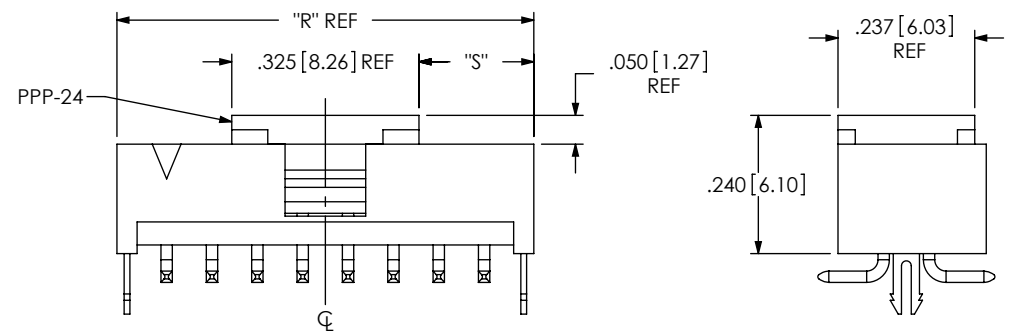

FIG 4  
-P: PICK AND PLACE PAD  
LTMM-108-01-XX-D-SM-LC-P SHOWN  
FOR SURFACE MOUNT OPTIONS ONLY  
(ONLY AVAILABLE IN 04-25 POSITIONS)  
(DIFFERENT AS SHOWN, OTHERWISE SAME AS FIG 3)

NOTE: "R" = USED MEASURED DIMENSION  
"S" = {"R"-.325 [8.26]} / 2 ±.020 [.51]

PROPRIETARY NOTE  
THIS DOCUMENT CONTAINS INFORMATION  
CONFIDENTIAL AND PROPRIETARY TO  
SAMTEC, INC. AND SHALL NOT BE REPRODUCED  
OR TRANSFERRED TO OTHER DOCUMENTS OR  
DISCLOSED TO OTHERS OR USED FOR ANY  
PURPOSE OTHER THAN THAT WHICH IT WAS  
OBTAINED WITHOUT THE EXPRESSED WRITTEN  
CONSENT OF SAMTEC, INC.

DO NOT SCALE DRAWING  
SHEET SCALE: 3:1

**samtec**  
520 PARK EAST BLVD, NEW ALBANY, IN 47150  
PHONE: 812-944-6733 FAX: 812-948-5047  
e-Mail: info@SAMTEC.com code: 55322

DESCRIPTION:  
LTMM ASSEMBLY

DWG. NO.  
LTMM-1XX-XX-XX-D-XX-XX

BY: BRYAN T 05/28/1992 SHEET 2 OF 4

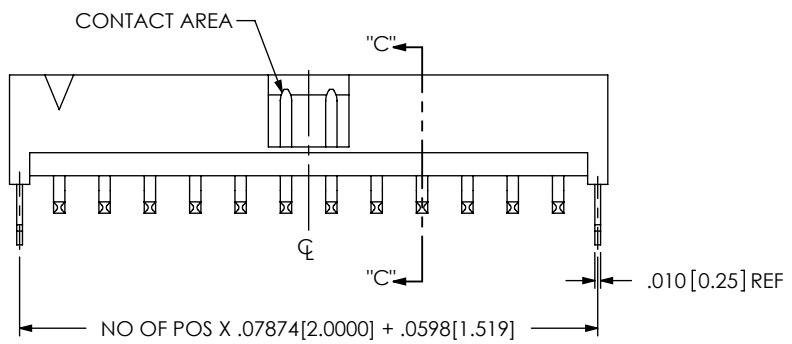
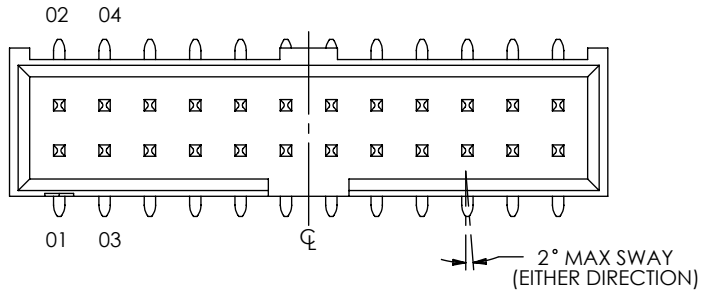
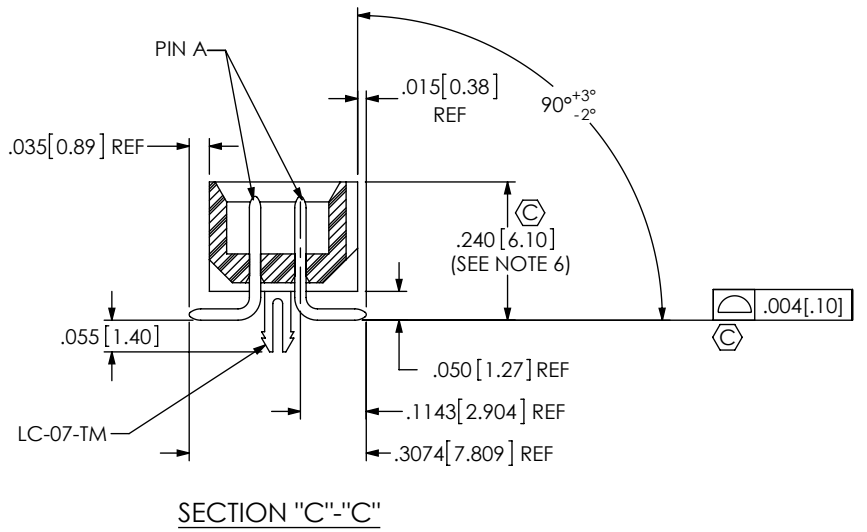
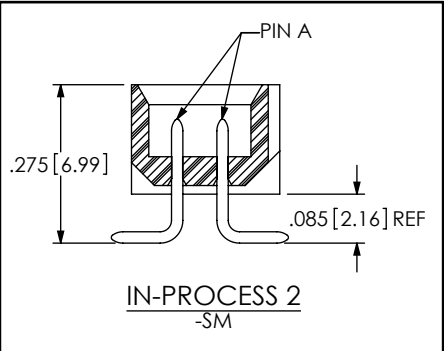
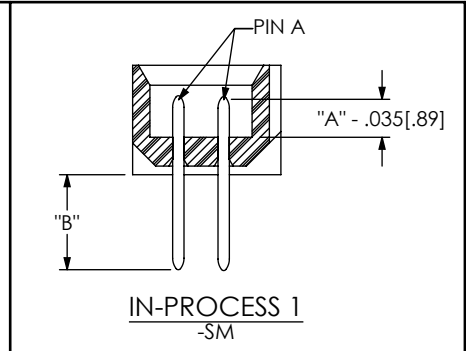

FIG 3  
SURFACE MOUNT  
LTMM-108-01-XX-D-SM-LC SHOWN  
(DIFFERENT AS SHOWN, OTHERWISE SAME AS FIG 1)



SECTION "C"-"C"

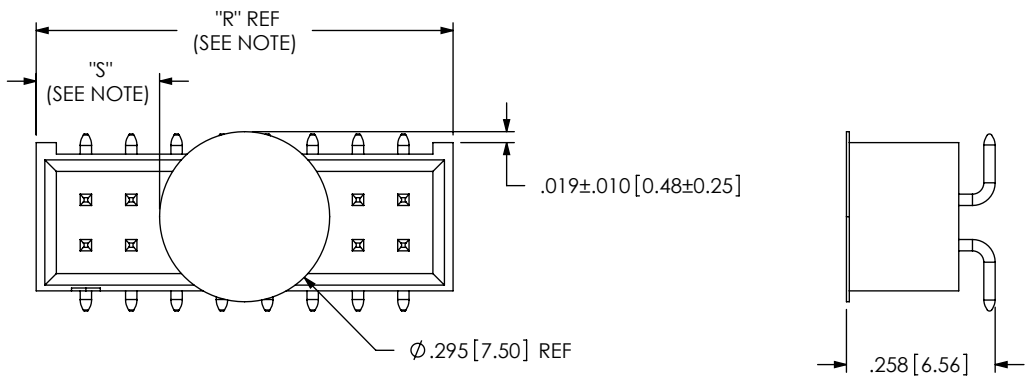

FIG 6  
-K OPTION (POLYIMIDE FILM)  
LTMM-108-01-XX-D-SM-K SHOWN  
FOR SURFACE MOUNT OPTIONS ONLY  
(DIFFERENT AS SHOWN, OTHERWISE SAME AS FIG 3)

NOTE: "R" = USED MEASURED DIMENSION  
"S" = {("R"-.2953 [7.500]) / 2} ±.020 [.51]

PROPRIETARY NOTE  
THIS DOCUMENT CONTAINS INFORMATION  
CONFIDENTIAL AND PROPRIETARY TO  
SAMTEC, INC. AND SHALL NOT BE REPRODUCED  
OR TRANSFERRED TO OTHER DOCUMENTS OR  
DISCLOSED TO OTHERS OR USED FOR ANY  
PURPOSE OTHER THAN THAT WHICH IT WAS  
OBTAINED WITHOUT THE EXPRESSED WRITTEN  
CONSENT OF SAMTEC, INC.

DO NOT SCALE DRAWING  
SHEET SCALE: 3:1



520 PARK EAST BLVD, NEW ALBANY, IN 47150  
PHONE: 812-944-6733 FAX: 812-948-5047  
e-Mail: info@SAMTEC.com code: 55322

DESCRIPTION:  
LTMM ASSEMBLY

DWG. NO.  
LTMM-1XX-XX-XX-D-XX-XX

BY: BRYAN T 05/28/1992 SHEET 3 OF 4

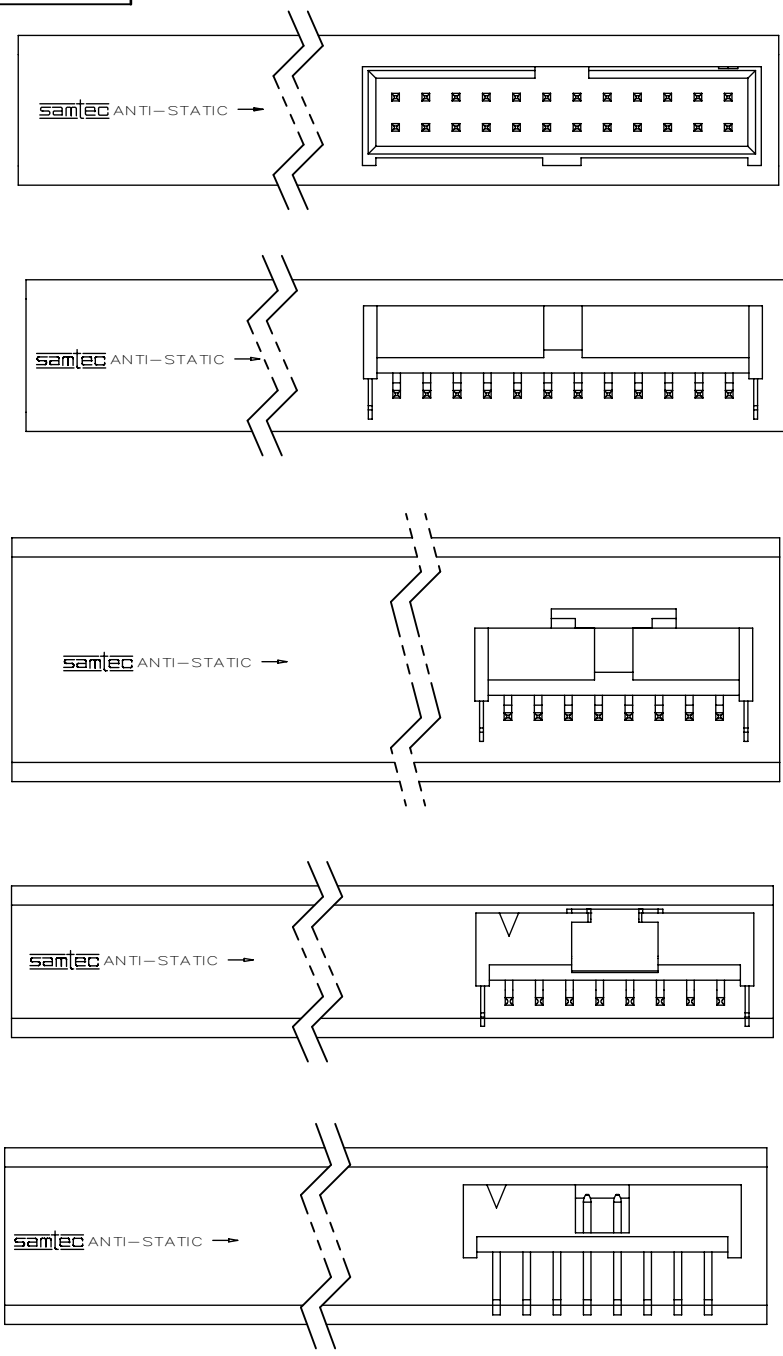

FIG 8  
TUBE PACKAGING VIEW

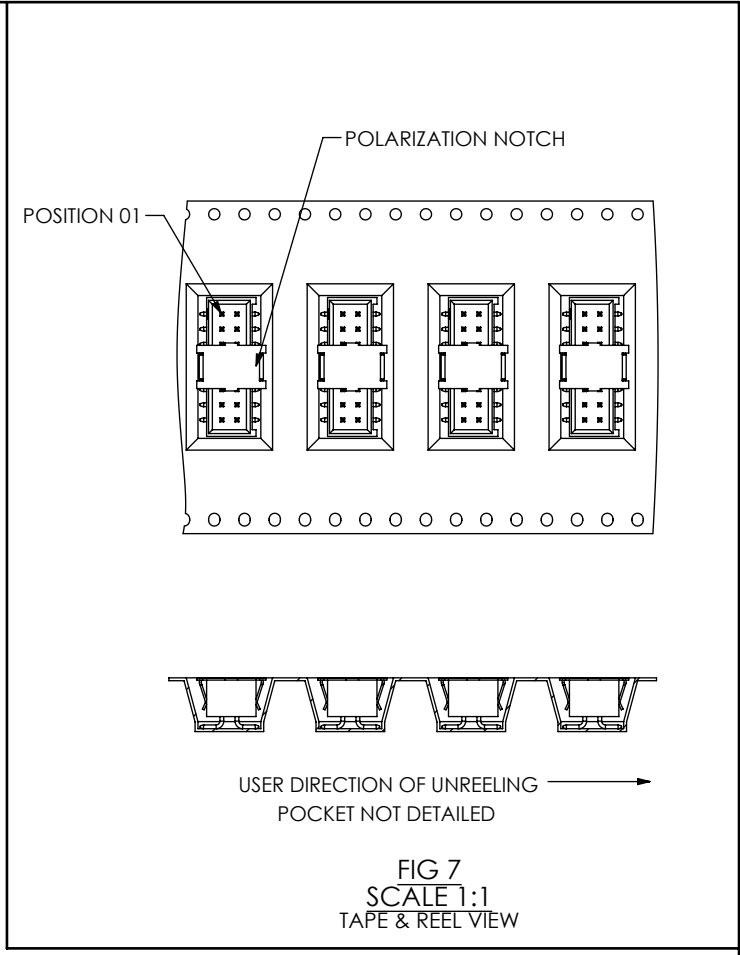
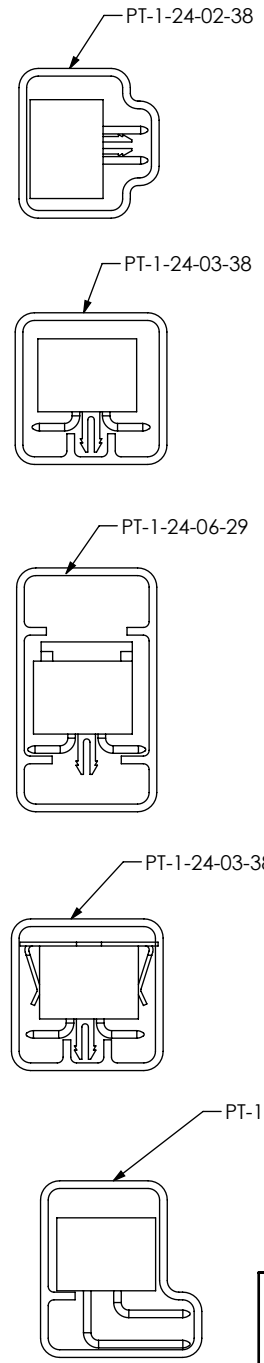

FIG 7  
SCALE 1:1  
TAPE & REEL VIEW

TABLE 2		
OPTIONS	PACKAGING TUBE	PLUG
STANDARD, -LC	PT-1-24-02-38	TP-03
-SM, -SM-LC, -SM-M	PT-1-24-03-38	TP-03
-SM-LC-P, -SM-P	PT-1-24-06-29	TP-07
-RA	PT-1-24-01-45	TP-03

**PROPRIETARY NOTE**  
 THIS DOCUMENT CONTAINS INFORMATION CONFIDENTIAL AND PROPRIETARY TO SAMTEC, INC. AND SHALL NOT BE REPRODUCED OR TRANSFERRED TO OTHER DOCUMENTS OR DISCLOSED TO OTHERS OR USED FOR ANY PURPOSE OTHER THAN THAT WHICH IT WAS OBTAINED WITHOUT THE EXPRESSED WRITTEN CONSENT OF SAMTEC, INC.

DO NOT SCALE DRAWING

SHEET SCALE: 2:1

**samtec**

520 PARK EAST BLVD, NEW ALBANY, IN 47150  
 PHONE: 812-944-6733 FAX: 812-948-5047  
 e-Mail: info@SAMTEC.com code: 55322

DESCRIPTION:  
 LTMM ASSEMBLY

DWG. NO.  
**LTMM-1XX-XX-XX-D-XX-XX**

BY: BRYAN T 05/28/1992 SHEET 4 OF 4