

Digital transistors (built-in resistor)

DTC143TM / DTC143TH / DTC143TE / DTC143TUA / DTC143TKA / DTC143TSA

●Features

- 1) Built-in bias resistors enable the configuration of an inverter circuit without connecting external input resistors (see equivalent circuit).
- 2) The bias resistors consist of thin-film resistors with complete isolation to allow negative biasing of the input. They also have the advantage of almost completely eliminating parasitic effects.
- 3) Only the on/off conditions need to be set for operation, making device design easy.

●Equivalent circuit

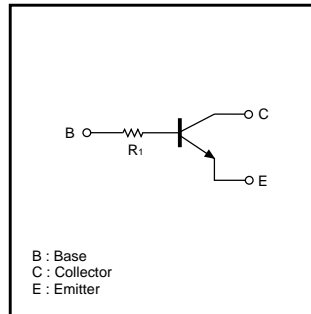

●Structure

PNP digital transistor
(Built-in resistor type)

●External dimensions (Units : mm)

<p>DTC143TM</p> <p>ROHM : VMT3 Abbreviated symbol : 03</p> <p>(1) Base (2) Emitter (3) Collector</p>	<p>DTC143TH</p> <p>ROHM : EMT3 Flat lead EIAJ : SC-89 Abbreviated symbol : 03</p> <p>(1) Base (2) Emitter (3) Collector</p>
<p>DTC143TE</p> <p>ROHM : EMT3 Abbreviated symbol : 03</p> <p>(1) Emitter (2) Base (3) Collector</p>	<p>DTC143TUA</p> <p>ROHM : UMT3 EIAJ : SC-70 Abbreviated symbol : 03</p> <p>(1) Emitter (2) Base (3) Collector</p>
<p>DTC143TKA</p> <p>ROHM : SMT3 EIAJ : SC-59 Abbreviated symbol : 03</p> <p>(1) Emitter (2) Base (3) Collector</p>	<p>DTC143TSA</p> <p>ROHM : SPT EIAJ : SC-72 Abbreviated symbol : 03</p> <p>(1) Emitter (2) Collector (3) Base</p>

DTC143TM / DTC143TH / DTC143TE / DTC143TUA

Transistors

DTC143TKA / DTC143TSA

●Absolute maximum ratings (Ta=25°C)

Parameter	Symbol	Limits(DTC143T□)						Unit
		M	H	E	UA	KA	SA	
Collector-base voltage	V _{CB0}	50						V
Collector-emitter voltage	V _{CE0}	50						V
Emitter-base voltage	V _{EB0}	5						V
Collector current	I _c	100						mA
Collector power dissipation	P _c	150		200		300		mW
Junction temperature	T _j	150						°C
Storage temperature	T _{stg}	-55~+150						°C

●Electrical characteristics (Ta=25°C)

Parameter	Symbol	Min.	Typ.	Max.	Unit	Conditions
Collector-base breakdown voltage	BV _{CB0}	50	–	–	V	I _c =50μA
Collector-emitter breakdown voltage	BV _{CE0}	50	–	–	V	I _c =1mA
Emitter-base breakdown voltage	BV _{EB0}	5	–	–	V	I _E =50μA
Collector cutoff current	I _{cBO}	–	–	0.5	μA	V _{CB} =50V
Emitter cutoff current	I _{EBO}	–	–	0.5	μA	V _{EB} =4V
Collector-emitter saturation voltage	V _{CE(sat)}	–	–	0.3	V	I _c /I _B =5mA/0.25mA
DC current transfer ratio	h _{FE}	100	250	600	–	I _c =1mA, V _{CE} =5V
Input resistance	R _i	3.29	4.7	6.11	kΩ	–
Transition frequency	f _t	–	250	–	MHz	V _{CE} =10V, I _E =-5mA, f=100MHz *

* Transition frequency of the device

●Packaging specifications

Type	Package	VMT3	EMT3 Flat lead	EMT3	UMT3	SMT3	SPT
	Packaging type	Taping	Taping	Taping	Taping	Taping	Taping
	Code	T2L	T2L	TL	T106	T146	TP
	Basic ordering unit (pieces)	8000	8000	3000	3000	3000	5000
DTC143TM		○	–	–	–	–	–
DTC143TH		–	○	–	–	–	–
DTC143TE		–	–	○	–	–	–
DTC143TUA		–	–	–	○	–	–
DTC143TKA		–	–	–	–	○	–
DTC143TSA		–	–	–	–	–	○

●Electrical characteristic curves

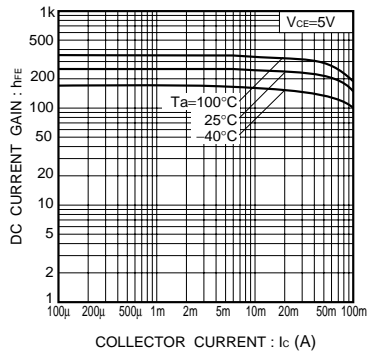

Fig.1 DC current gain vs. collector current

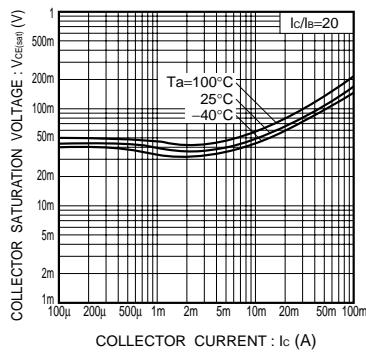

Fig.2 Collector-emitter saturation voltage vs. collector current