

CLASS C, 940 MHz, 7 VOLT POWER TRANSISTOR

NE090101-07
NEM090301-07
NEM090701-07

FEATURES

- HIGH POWER AND GAIN
- LOW COST
- WIDE BANDWIDTH
- SMALL PACKAGE
- GOLD METALLIZATION
- RUGGED VSWR: ∞

DESCRIPTION

The NE0900-07 and NEM0900-07 series of NPN silicon epitaxial UHF power transistors are designed specifically for hand-held radio applications with a supply voltage of 7.2 V. The series is available in a chip carrier package offering power levels of 1, 3 and 7 watts in the 800 to 900 MHz band. The input matching network is incorporated for the NEM0900-07 series to simplify circuit designs. The series features high gain, power, efficiency, and resistance to burn-out resulting from load mismatch.

4

ELECTRICAL CHARACTERISTICS (TA = 25°C)

| PART NUMBER EIAJ ¹ REGISTERED NUMBER PACKAGE OUTLINE | | | NE090101-07 2SC3814 01 | | | NEM090301-07 2SC3815 01 | | | NEM090701-07 2SC3816 01 | | |
|---|---|-------------|------------------------------|-----|-----|-------------------------------|-----|------|-------------------------------|-----|-----|
| SYMBOLS | PARAMETERS AND CONDITIONS | UNITS | MIN | TYP | MAX | MIN | TYP | MAX | MIN | TYP | MAX |
| P _{OUT} | Output Power at V _{CC} = 7.2 V, f = 940 MHz, P _{IN} = 0.1 W P _{IN} = 0.7 W P _{IN} = 2.3 W | W W W | 0.8 | 1 | | 2.5 | 3.2 | | 5 | 6.3 | |
| η_c | Collector Efficiency at V _{CC} = 7.2 V, f = 940 MHz, P _{IN} = 0.1 W P _{IN} = 0.7 W P _{IN} = 2.3 W | | 50 | 55 | | 55 | 65 | | 55 | 65 | |
| I _{CBO} | Collector Cutoff Current at V _{CB} = 15 V, I _E = 0 | mA | | | 0.1 | | | 0.25 | | | 0.5 |
| I _{EBO} | Emitter Cutoff Current at V _{EB} = 1.5 V, I _C = 0 | mA | | | 0.1 | | | 0.25 | | | 0.5 |
| h _{FE} | DC Forward Current Gain at V _{CE} = 7V, I _C = 0.1 A (pulsed) I _C = 0.2 A (pulsed) I _C = 0.4 A (pulsed) | | 20 | 60 | 200 | 20 | 60 | 200 | 20 | 100 | 200 |
| C _{OB} | Output Capacitance ² at V _{CB} = 10 V, I _E = 0, f = 1 MHz | pF | | | 5 | | | 20 | | | 40 |

Notes:

1. Electronic Industrial Association of Japan.
2. The emitter terminal should be connected to the guard terminal at the three-terminal capacitance bridge.

NE090101-07, NEM090301-07, NEM090701-07

ABSOLUTE MAXIMUM RATINGS¹ (T_A = 25°C)

| PART NUMBER PACKAGE OUTLINE | | | NE090101-07 01 | NEM090301-07 01 | NEM090701-07 01 |
|--------------------------------|--|-------|-------------------|--------------------|--------------------|
| SYMBOLS | PARAMETERS | UNITS | RATINGS | RATINGS | RATINGS |
| V _{CB0} | Collector to Base Voltage | V | 20 | 20 | 20 |
| V _{CE0} | Collector to Emitter Voltage | V | 12 | 12 | 12 |
| V _{EB0} | Emitter to Base Voltage | V | 2 | 2 | 2 |
| I _C | Collector Current | A | 0.5 | 1.5 | 3.0 |
| R _{TH(J-C)} | Thermal Resistance (Junction-to-Case) | °C/W | 21 | 10 | 5 |
| P _T | Total Power Dissipation (T _C = 25°C) | W | 8.3 | 17.5 | 35 |
| T _J | Junction Temperature | °C | 200 | 200 | 200 |
| T _{STG} | Storage Temperature | °C | -65 to +150 | -65 to +150 | -65 to +150 |

Note:

1. Operation in excess of any one of these parameters may result in permanent damage.

TYPICAL PERFORMANCE CURVES (T_A = 25°C)

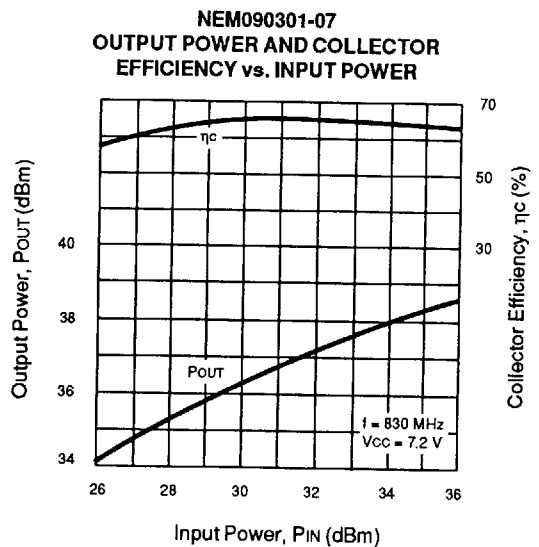
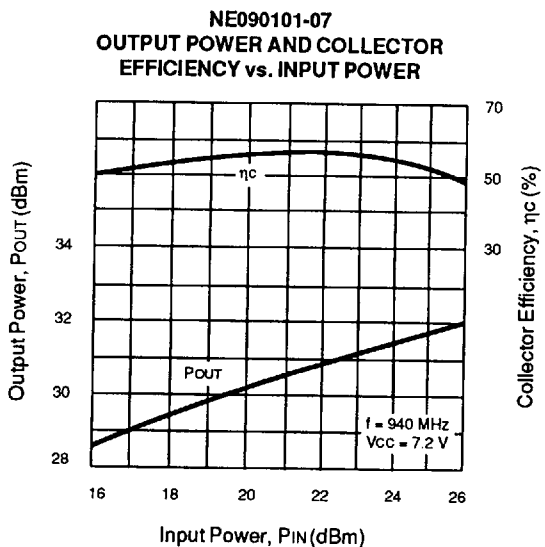
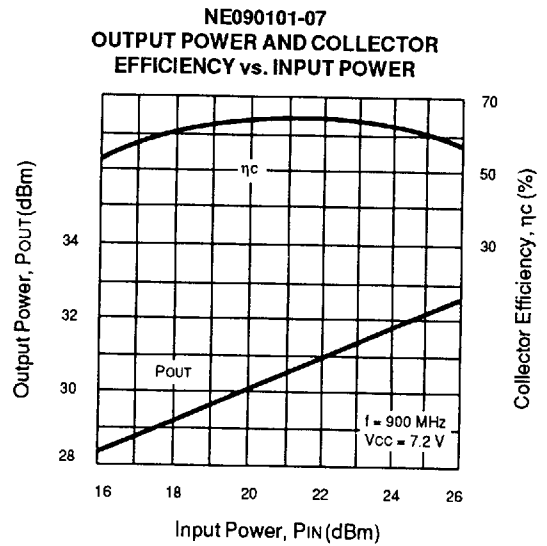
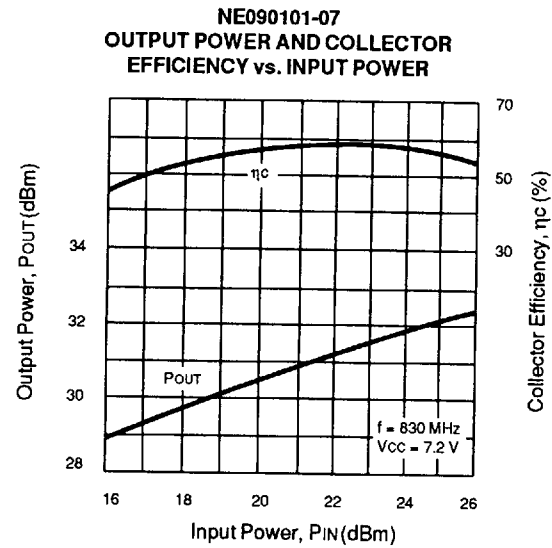

TYPICAL PERFORMANCE CURVES ($T_A = 25^\circ\text{C}$)

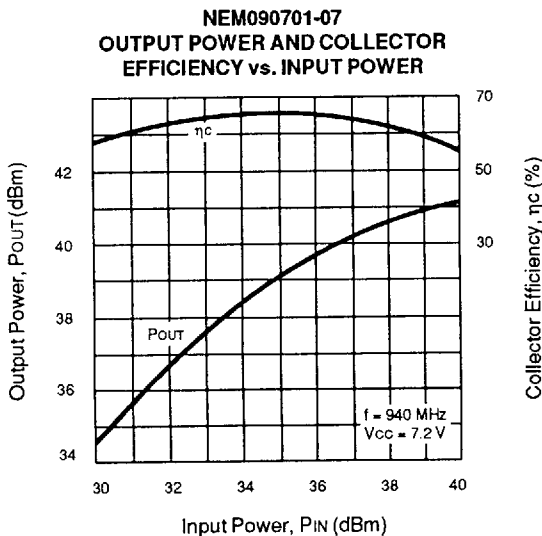
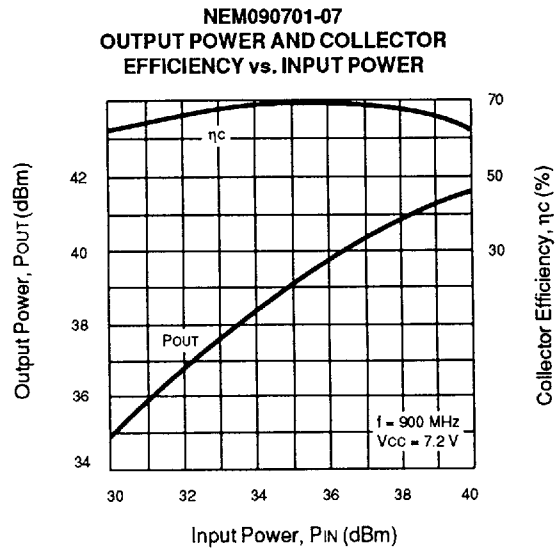
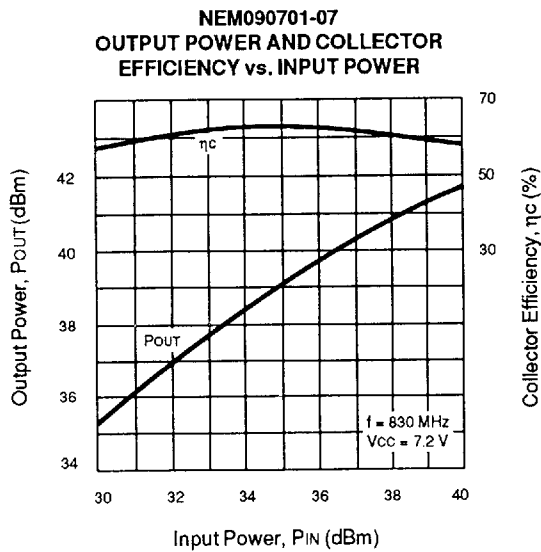
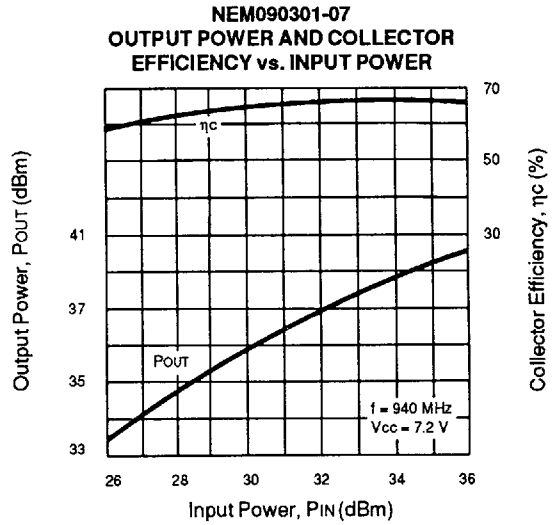
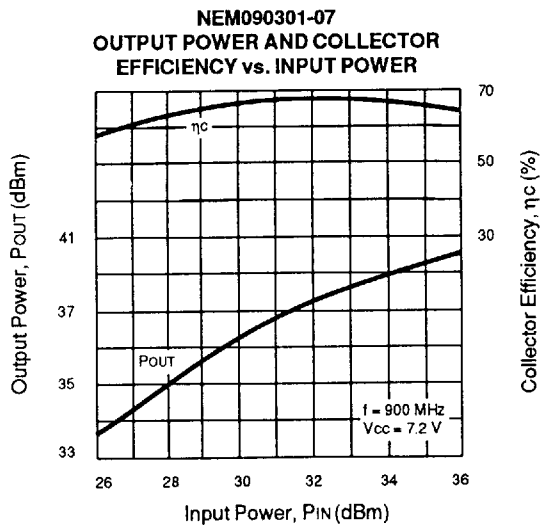

4

OUTLINE DIMENSIONS (Units in mm)

PACKAGE OUTLINE 01

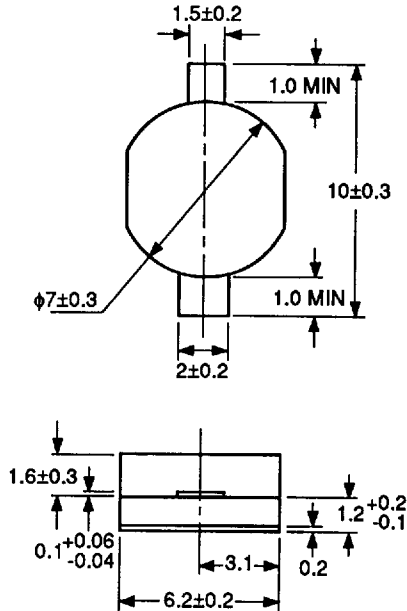

APPLICATIONS

RECOMMENDED LINE UP FOR NE0900-07 AND NEM0900-07 SERIES (Vcc = 7.2 V)

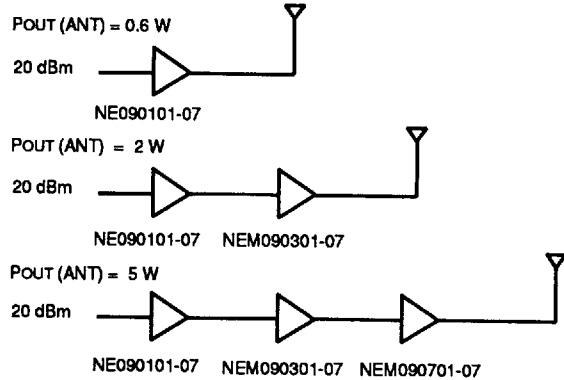

TYPICAL INPUT/OUTPUT LOAD IMPEDANCE¹

| PART NUMBER | FREQUENCY (MHz) | Z _{IN} (Ω) | Z _L (Ω) |
|--------------|-----------------|---------------------|--------------------|
| NE090101-07 | 830 | 2.9 +j4.4 | 11.3 -j2.5 |
| | 900 | 2.6 +j5.7 | 9.2 -j3.8 |
| | 940 | 2.0 +j5.7 | 6.9 -j0.9 |
| NEM090301-07 | 830 | 3.5 +j6.6 | 3.5 +j2.6 |
| | 900 | 5.6 +j7.4 | 2.9 +j3.0 |
| | 940 | 7.3 +j7.3 | 2.9 +j3.5 |
| NEM090701-07 | 830 | 2.3 +j4.8 | 2.3 +j3.5 |
| | 900 | 2.9 +j5.7 | 2.9 +j3.9 |
| | 940 | 2.9 +j6.1 | 2.6 +j4.8 |

Note:

1. Typical Large Signal Impedances at Vcc = 7 V.

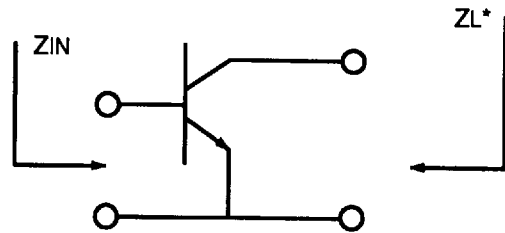

*Z_L is optimum load impedance at rated output power.

ASSEMBLY INSTRUCTION AND BeO WARNING

HANDLING PRECAUTIONS

This product contains beryllium oxide (BeO) ceramic. Beryllium oxide powder or vapor is highly toxic and can be fatal. Parts containing beryllia shall not be ground, sandblasted, machined, or have other operations performed on them which will produce beryllia or beryllium dust. Furthermore, beryllium oxide packages shall not be placed in acids that will produce forms containing beryllium. Do not dispose of this product with common household or industrial waste. Disposal of this product may be subject to hazardous waste procedures dictated by your government, state or local laws.

INSTALLATION PROCEDURE

• Solder the emitter surface to the heat sink. Then solder the base and the collector leads to the printed circuit board. A soldering temperature of 260°C or less for 10 seconds or less is recommended.

- To relieve stress, leave a gap between the printed circuit board and the leads to the base and the emitter.
- When soldering the emitter terminal surface to the heat sink, make sure that the solder covers the entire collector terminal surface and that it is securely fixed to the heat sink. Improper soldering will result in increased thermal resistance, etc. The use of a flux, a soldering temperature of 200°C or less, and a reflow within 1 minute are recommended.
- If the base of the emitter lead or the heat sink surface is either soldered at a temperature that is too high or soldered for too long, the connection may peel. Follow the temperature and the time recommendations given above.