

FAST RECOVERY RECTIFIER DIODES

FEATURES

- VERY LOW REVERSE RECOVERY TIME
- VERY LOW SWITCHING LOSSES
- LOW NOISE TURN-OFF SWITCHING
- INSULATED PACKAGE :
 Insulating voltage = 2500 V_{RMS}
 Capacitance = 45 pF

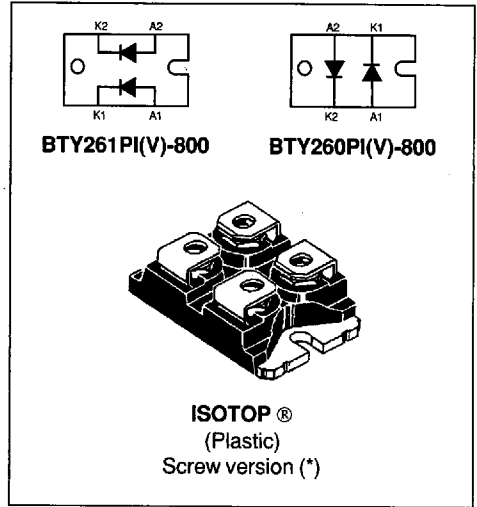

DESCRIPTION

Dual high voltage rectifiers ranging from 600V to 800V suited for Switch Mode Power Supplies and other power converters.
 The devices are packaged in ISOTOP.

ABSOLUTE MAXIMUM RATINGS

Symbol	Parameter		Value	Unit
I _{FRM}	Repetitive peak forward current	tp ≤ 10μs	750	A
I _{F(RMS)}	RMS forward current	Per diode	140	A
I _{F(AV)}	Average forward current	T _c =60°C δ = 0.5 Per diode	60	A
I _{FSM}	Surge non repetitive forward current	tp=10ms sinusoidal Per diode	400	A
T _{stg} T _J	Storage and junction temperature range		- 40 to + 150 - 40 to + 150	°C °C

Symbol	Parameter	BYT260PI(V)- / BYT261PI(V)-		Unit
		600	800	
V _{RRM}	Repetitive peak reverse voltage	600	800	V

* : Tin plated Fast-on version is also available (without V suffix).

TM : ISOTOP is a trademark of SGS-THOMSON Microelectronics.

THERMAL RESISTANCE

Symbol	Parameter		Value	Unit
Rth (j-c)	Junction to case	Per diode	0.7	°C/W
		Total	0.4	
Rth (c)	Coupling		0.1	°C/W

When the diodes 1 and 2 are used simultaneously :

$$\Delta T_{j(\text{diode } 1)} = P(\text{diode } 1) \times R_{th}(\text{Per diode}) + P(\text{diode } 2) \times R_{th}(c)$$

ELECTRICAL CHARACTERISTICS (Per diode)
STATIC CHARACTERISTICS

Symbol	Test Conditions		Min.	Typ.	Max.	Unit
V _F *	T _j = 25°C	I _F = 60 A			1.9	V
	T _j = 100°C				1.8	
I _R **	T _j = 25°C	V _R = V _{RRM}			100	μA
	T _j = 100°C				6	mA

Pulse test : * tp = 380 μs, duty cycle < 2 %

** tp = 5 ms, duty cycle < 2 %

RECOVERY CHARACTERISTICS

Symbol	Test Conditions		Min.	Typ.	Max.	Unit
trr	T _j = 25°C	I _F = 0.5A I _{rr} = 0.25A I _R = 1A			65	ns
		I _F = 1A dI _F /dt = -15A/μs V _R = 30V			135	

TURN-OFF SWITCHING CHARACTERISTICS (Without serie inductance)

Symbol	Test Conditions		Min.	Typ.	Max.	Unit
t _{IRM}	dI _F /dt = -240A/μs	V _{CC} = 200V I _F = 60A L _p ≤ 0.05μH T _j = 100°C see fig. 11			160	ns
	dI _F /dt = -480A/μs			100		
I _{RM}	dI _F /dt = -240A/μs				30	A
	dI _F /dt = -480A/μs			38		

TURN-OFF OVERVOLTAGE COEFFICIENT (With serie inductance)

Symbol	Test Conditions		Min.	Typ.	Max.	Unit
C = $\frac{V_{RP}}{V_{CC}}$	T _j = 100°C V _{CC} = 150V I _F = I _{F(AV)} dI _F /dt = -60A/μs L _p = 2μH see fig.12			3.3	4	/

To evaluate the conduction losses use the following equation :

$$P = 1.47 \times I_{F(AV)} + 0.005 \times I_{F(RMS)}^2$$

Fig.1 : Low frequency power losses versus average current.

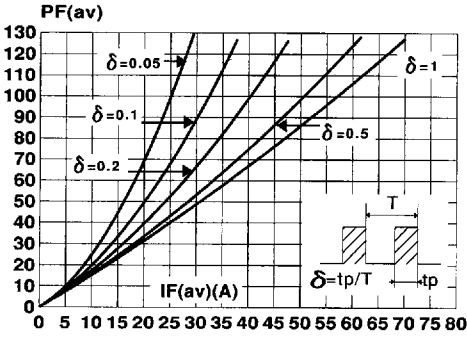

Fig.2 : Peak current versus form factor.

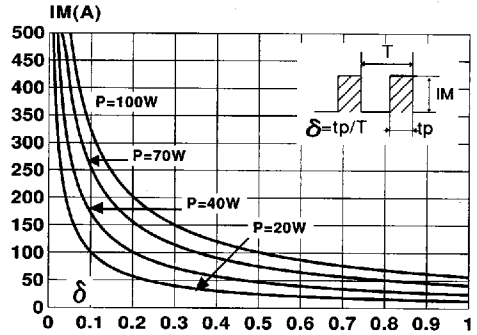

Fig.3 : Non repetitive peak surge current versus overload duration.

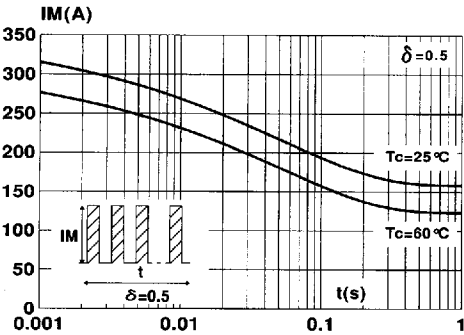

Fig.4 : Relative variation of thermal impedance junction to case versus pulse duration.

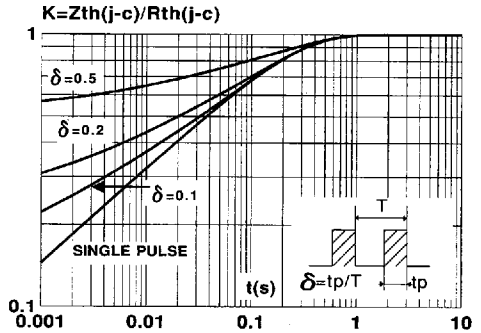

Fig.5 : Voltage drop versus forward current.

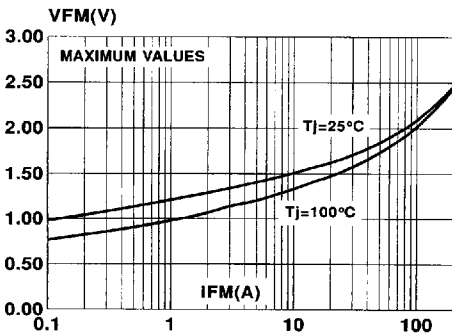

Fig.6 : Recovery charge versus diF/dt.

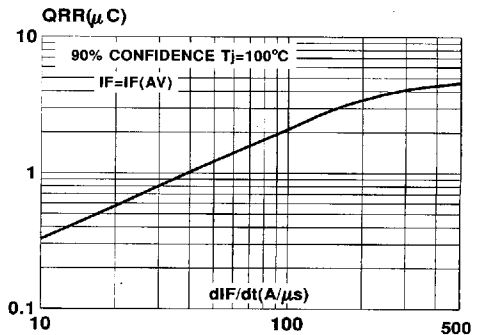

Fig.7 : Recovery time versus di_F/dt .

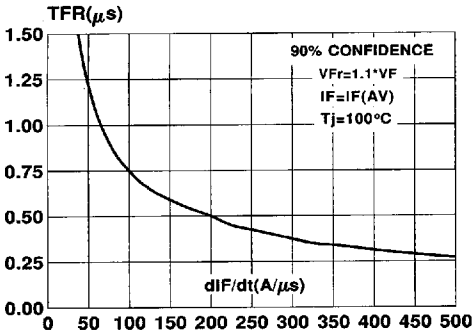

Fig.8 : Peak reverse current versus di_F/dt .

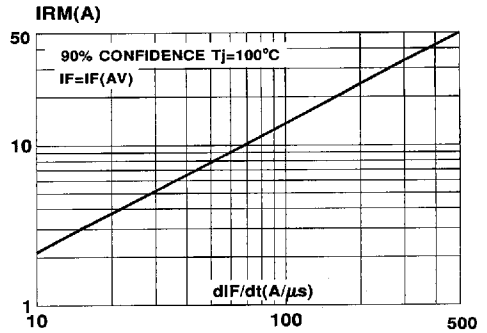

Fig.9 : Peak forward voltage versus di_F/dt .

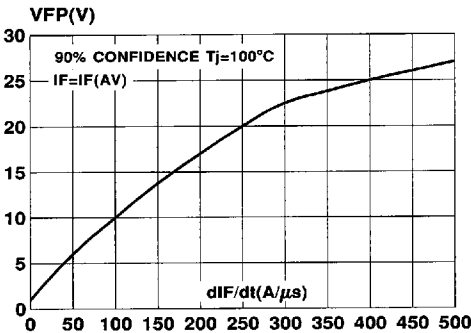

Fig.10 : Dynamic parameters versus junction temperature.

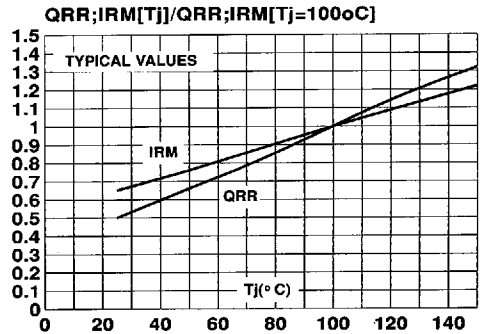

Fig.11 : TURN-OFF SWITCHING CHARACTERISTICS (Without serie inductance)

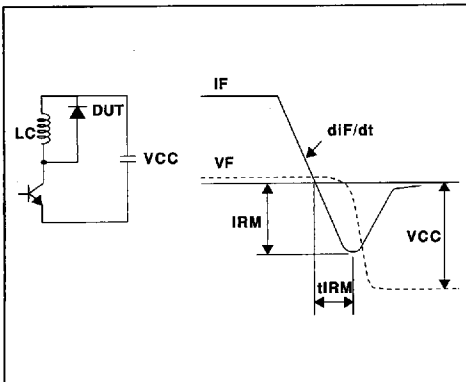

Fig.12 : TURN-OFF SWITCHING CHARACTERISTICS (With serie inductance)

