

# SN54HC251, SN74HC251 DATA SELECTORS/MULTIPLEXERS WITH 3-STATE OUTPUTS

SCLS132C – DECEMBER 1982 – REVISED FEBRUARY 1999

- 3-State Version of 'HC151
- High-Current 3-State Outputs Interface Directly With System Bus or Can Drive up to 15 LSTTL Loads
- Perform Parallel-to-Serial Conversion
- Complementary Outputs Provide True and Inverted Data
- Package Options Include Plastic Small-Outline (D), Shrink Small-Outline (DB), and Ceramic Flat (W) Packages, Ceramic Chip Carriers (FK), and Standard Plastic (N) and Ceramic (J) DIPs

## description

These data selectors/multiplexers contain full binary decoding to select 1-of-8 data sources and feature strobe-controlled complementary 3-state outputs.

The 3-state outputs can interface with and drive data lines of bus-organized systems. With all but one of the common outputs disabled (in the high-impedance state), the low impedance of the single enabled output drives the bus line to a high or low logic level. Both outputs are controlled by the output-enable ( $\overline{OE}$ ) input. The outputs are disabled when  $\overline{OE}$  is high.

The SN54HC251 is characterized for operation over the full military temperature range of  $-55^{\circ}\text{C}$  to  $125^{\circ}\text{C}$ . The SN74HC251 is characterized for operation from  $-40^{\circ}\text{C}$  to  $85^{\circ}\text{C}$ .

SN54HC251 . . . J OR W PACKAGE  
SN74HC251 . . . D, DB, OR N PACKAGE  
(TOP VIEW)

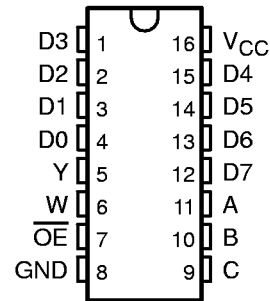

SN54HC251 . . . FK PACKAGE  
(TOP VIEW)

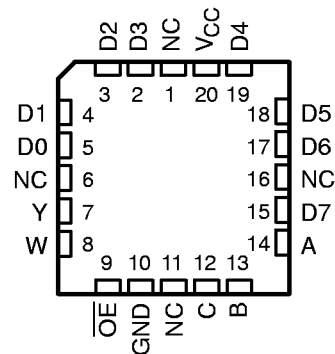

NC – No internal connection



Please be aware that an important notice concerning availability, standard warranty, and use in critical applications of Texas Instruments semiconductor products and disclaimers thereto appears at the end of this data sheet.

PRODUCTION DATA information is current as of publication date. Products conform to specifications per the terms of Texas Instruments standard warranty. Production processing does not necessarily include testing of all parameters.

**TEXAS  
INSTRUMENTS**

POST OFFICE BOX 655303 • DALLAS, TEXAS 75265

Copyright © 1999, Texas Instruments Incorporated  
On products compliant to MIL-PRF-38535, all parameters are tested unless otherwise noted. On all other products, production processing does not necessarily include testing of all parameters.

# SN54HC251, SN74HC251 DATA SELECTORS/MULTIPLEXERS WITH 3-STATE OUTPUTS

SCLS132C – DECEMBER 1982 – REVISED FEBRUARY 1999

FUNCTION TABLE

INPUTS				OUTPUTS	
SELECT			$\overline{OE}$	Y	W
C	B	A			
X	X	X	H	Z	$\overline{Z}$
L	L	L	L	D0	$\overline{D0}$
L	L	H	L	D1	$\overline{D1}$
L	H	L	L	D2	$\overline{D2}$
L	H	H	L	D3	$\overline{D3}$
H	L	L	L	D4	$\overline{D4}$
H	L	H	L	D5	$\overline{D5}$
H	H	L	L	D6	$\overline{D6}$
H	H	H	L	D7	$\overline{D7}$

D0, D1 . . . D7 = the level of the respective D input

## logic symbol†

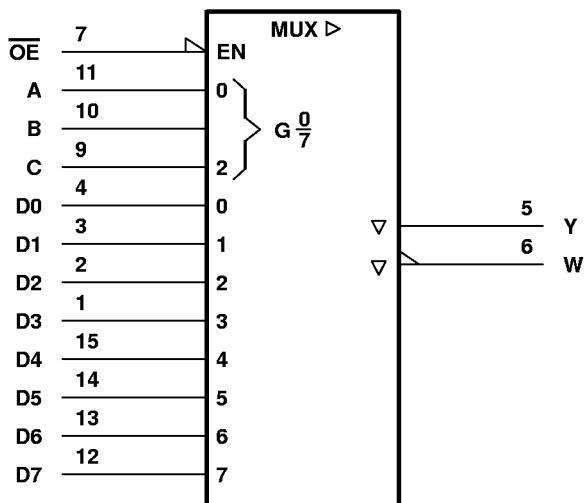

† This symbol is in accordance with ANSI/IEEE Std 91-1984 and IEC Publication 617-12.  
Pin numbers shown are for the D, DB, J, N, and W packages.

**SN54HC251, SN74HC251**  
**DATA SELECTORS/MULTIPLEXERS**  
**WITH 3-STATE OUTPUTS**

SCLS132C – DECEMBER 1982 – REVISED FEBRUARY 1999

**logic diagram (positive logic)**

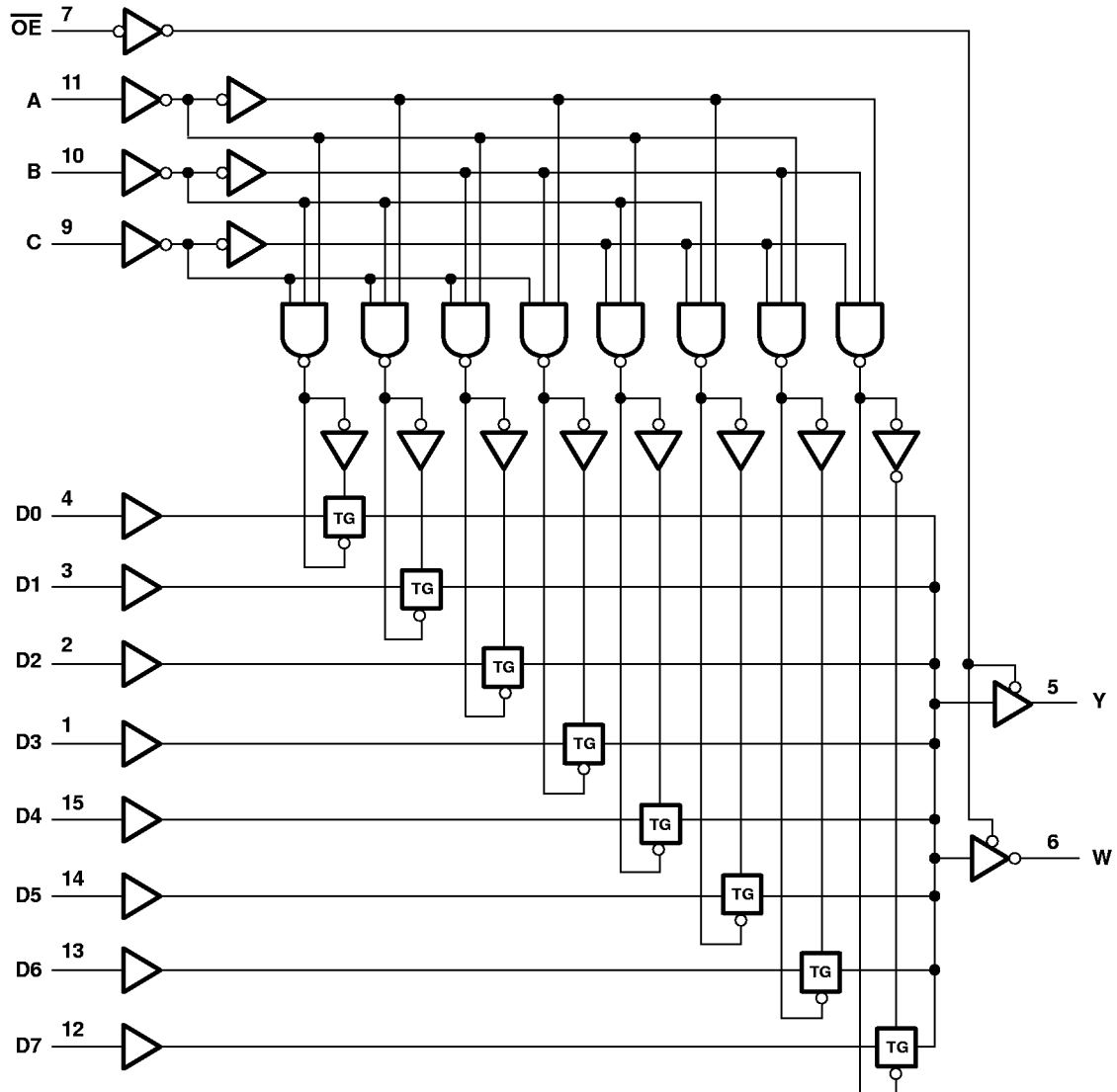

Pin numbers shown are for the D, DB, J, N, and W packages.



# SN54HC251, SN74HC251 DATA SELECTORS/MULTIPLEXERS WITH 3-STATE OUTPUTS

SCLS132C – DECEMBER 1982 – REVISED FEBRUARY 1999

## absolute maximum ratings over operating free-air temperature range†

Supply voltage range, $V_{CC}$ .....	-0.5 V to 7 V
Input clamp current, $I_{IK}$ ( $V_I < 0$ or $V_I > V_{CC}$ ) (see Note 1) .....	$\pm 20$ mA
Output clamp current, $I_{OK}$ ( $V_O < 0$ or $V_O > V_{CC}$ ) (see Note 1) .....	$\pm 20$ mA
Continuous output current, $I_O$ ( $V_O = 0$ to $V_{CC}$ ) .....	$\pm 35$ mA
Continuous current through $V_{CC}$ or GND .....	$\pm 70$ mA
Package thermal impedance, $\theta_{JA}$ (see Note 2): D package .....	113°C/W
DB package .....	131°C/W
N package .....	78°C/W
Storage temperature range, $T_{stg}$ .....	-65°C to 150°C

† Stresses beyond those listed under “absolute maximum ratings” may cause permanent damage to the device. These are stress ratings only, and functional operation of the device at these or any other conditions beyond those indicated under “recommended operating conditions” is not implied. Exposure to absolute-maximum-rated conditions for extended periods may affect device reliability.

- NOTES: 1. The input and output voltage ratings may be exceeded if the input and output current ratings are observed.  
 2. The package thermal impedance is calculated in accordance with JESD 51, except for through-hole packages, which use a trace length of zero.

## recommended operating conditions (see Note 3)

		SN54HC251			SN74HC251			UNIT
		MIN	NOM	MAX	MIN	NOM	MAX	
$V_{CC}$	Supply voltage	2	5	6	2	5	6	V
$V_{IH}$	High-level input voltage	$V_{CC} = 2$ V		1.5	1.5		V	
		$V_{CC} = 4.5$ V		3.15	3.15			
		$V_{CC} = 6$ V		4.2	4.2			
$V_{IL}$	Low-level input voltage	$V_{CC} = 2$ V		0	0.5	0	0.5	V
		$V_{CC} = 4.5$ V		0	1.35	0	1.35	
		$V_{CC} = 6$ V		0	1.8	0	1.8	
$V_I$	Input voltage	0	$V_{CC}$		0	$V_{CC}$		V
$V_O$	Output voltage	0	$V_{CC}$		0	$V_{CC}$		V
$t_t$	Input transition (rise and fall) time	$V_{CC} = 2$ V		0	1000	0	1000	ns
		$V_{CC} = 4.5$ V		0	500	0	500	
		$V_{CC} = 6$ V		0	400	0	400	
$T_A$	Operating free-air temperature	-55		125	-40		85	°C

NOTE 3: All unused inputs of the device must be held at  $V_{CC}$  or GND to ensure proper device operation. Refer to the TI application report, *Implications of Slow or Floating CMOS Inputs*, literature number SCBA004.



**SN54HC251, SN74HC251**  
**DATA SELECTORS/MULTIPLEXERS**  
**WITH 3-STATE OUTPUTS**

SCLS132C – DECEMBER 1982 – REVISED FEBRUARY 1999

electrical characteristics over recommended operating free-air temperature range (unless otherwise noted)

PARAMETER	TEST CONDITIONS		V <sub>CC</sub>	T <sub>A</sub> = 25°C			SN54HC251		SN74HC251		UNIT	
				MIN	TYP	MAX	MIN	MAX	MIN	MAX		
V <sub>OH</sub>	V <sub>I</sub> = V <sub>IH</sub> or V <sub>IL</sub>	I <sub>OH</sub> = -20 μA	2 V	1.9	1.998		1.9		1.9	V		
			4.5 V	4.4	4.499		4.4		4.4			
			6 V	5.9	5.999		5.9		5.9			
		I <sub>OH</sub> = -6 mA	4.5 V	3.98	4.3		3.7		3.84			
		I <sub>OH</sub> = -7.8 mA	6 V	5.48	5.8		5.2		5.34			
V <sub>OL</sub>	V <sub>I</sub> = V <sub>IH</sub> or V <sub>IL</sub>	I <sub>OL</sub> = 20 μA	2 V		0.002	0.1		0.1		0.1	V	
			4.5 V		0.001	0.1		0.1		0.1		
			6 V		0.001	0.1		0.1		0.1		
		I <sub>OL</sub> = 6 mA	4.5 V		0.17	0.26		0.4		0.33		
		I <sub>OL</sub> = 7.8 mA	6 V		0.15	0.26		0.4		0.33		
I <sub>I</sub>	V <sub>I</sub> = V <sub>CC</sub> or 0		6 V		±0.1	±100		±1000		±1000	nA	
I <sub>OZ</sub>	V <sub>O</sub> = V <sub>CC</sub> or 0, V <sub>I</sub> = V <sub>IH</sub> or V <sub>IL</sub>		6 V		±0.01	±0.5		±10		±5	μA	
I <sub>CC</sub>	V <sub>I</sub> = V <sub>CC</sub> or 0, I <sub>O</sub> = 0		6 V				8		160		80	μA
C <sub>i</sub>			2 V to 6 V		3	10		10		10	pF	

switching characteristics over recommended operating free-air temperature range, C<sub>L</sub> = 50 pF (unless otherwise noted) (see Figure 1)

PARAMETER	FROM (INPUT)	TO (OUTPUT)	V <sub>CC</sub>	T <sub>A</sub> = 25°C			SN54HC251		SN74HC251		UNIT
				MIN	TYP	MAX	MIN	MAX	MIN	MAX	
t <sub>pd</sub>	A, B, or C	W or Y	2 V		58	205		300		256	ns
			4.5 V		21	41		60		51	
			6 V		19	35		51		44	
	Any D	W or Y	2 V		44	195		283		244	
			4.5 V		17	39		57		49	
			6 V		15	33		48		41	
t <sub>en</sub>	$\overline{OE}$	W or Y	2 V		30	145		210		181	ns
			4.5 V		10	29		42		36	
			6 V		9	25		36		31	
t <sub>dis</sub>	$\overline{OE}$	W or Y	2 V		25	195		283		244	ns
			4.5 V		15	39		57		49	
			6 V		14	33		48		41	
t <sub>t</sub>		W or Y	2 V		20	75		110		95	ns
			4.5 V		8	15		22		19	
			6 V		6	13		19		16	



**SN54HC251, SN74HC251**  
**DATA SELECTORS/MULTIPLEXERS**  
**WITH 3-STATE OUTPUTS**

SCLS132C – DECEMBER 1982 – REVISED FEBRUARY 1999

switching characteristics over recommended operating free-air temperature range,  $C_L = 150 \text{ pF}$   
(unless otherwise noted) (see Figure 1)

PARAMETER	FROM (INPUT)	TO (OUTPUT)	$V_{CC}$	$T_A = 25^\circ\text{C}$			SN54HC251		SN74HC251		UNIT
				MIN	TYP	MAX	MIN	MAX	MIN	MAX	
$t_{pd}$	A, B, or C	W or Y	2 V	72	300	450	375	ns			
			4.5 V	25	60	90	75				
			6 V	22	52	77	65				
	Any D	W or Y	2 V	59	300	450	375				
			4.5 V	21	60	90	75				
			6 V	18	52	77	65				
$t_{en}$	$\overline{\text{OE}}$	W or Y	2 V	50	230	340	285	ns			
			4.5 V	17	46	68	57				
			6 V	15	40	58	50				
$t_t$		W or Y	2 V	45	210	315	265	ns			
			4.5 V	17	42	63	53				
			6 V	13	36	53	45				

operating characteristics,  $T_A = 25^\circ\text{C}$

PARAMETER	TEST CONDITIONS	TYP	UNIT
$C_{pd}$ Power dissipation capacitance	No load	70	pF



PARAMETER MEASUREMENT INFORMATION

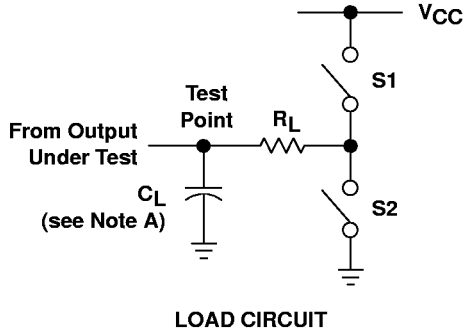

PARAMETER	$R_L$	$C_L$	S1	S2
$t_{en}$	1 k $\Omega$	50 pF or 150 pF	Open	Closed
			Closed	Open
$t_{dis}$	1 k $\Omega$	50 pF	Open	Closed
			Closed	Open
$t_{pd}$ or $t_t$	—	50 pF or 150 pF	Open	Open

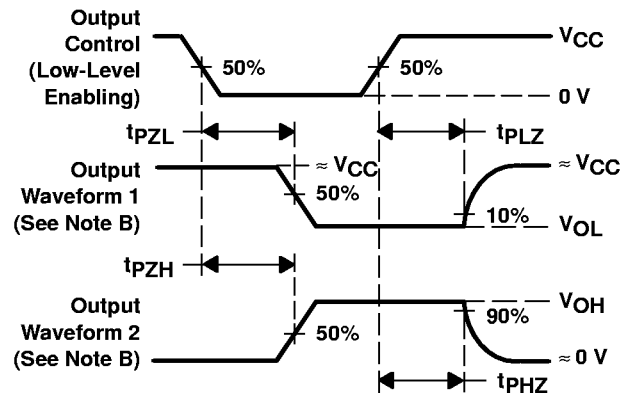
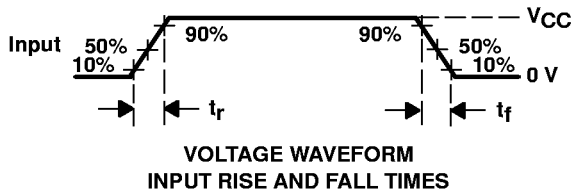
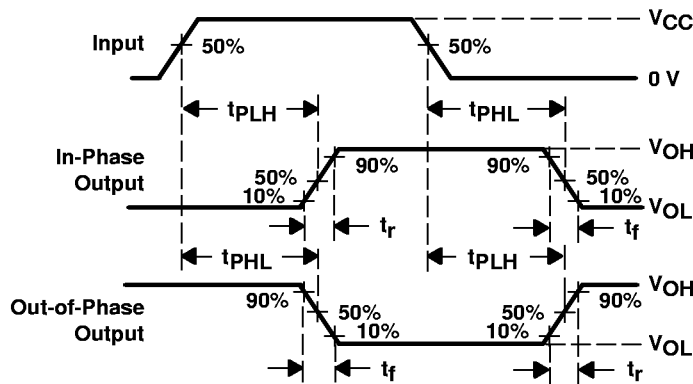

- NOTES: A.  $C_L$  includes probe and test-fixture capacitance.  
 B. Waveform 1 is for an output with internal conditions such that the output is low except when disabled by the output control. Waveform 2 is for an output with internal conditions such that the output is high except when disabled by the output control.  
 C. Phase relationships between waveforms were chosen arbitrarily. All input pulses are supplied by generators having the following characteristics:  $PRR \leq 1$  MHz,  $Z_O = 50 \Omega$ ,  $t_r = 6$  ns,  $t_f = 6$  ns.  
 D. The outputs are measured one at a time with one input transition per measurement.  
 E.  $t_{PLZ}$  and  $t_{PHZ}$  are the same as  $t_{dis}$ .  
 F.  $t_{PZL}$  and  $t_{PZH}$  are the same as  $t_{en}$ .  
 G.  $t_{PLH}$  and  $t_{PHL}$  are the same as  $t_{pd}$ .

Figure 1. Load Circuit and Voltage Waveforms