

.050" BOARD MOUNT SOCKETS (Straight / SMT)

FEATURES

- Excellent for low profile board stacking
- Small centers allow higher density packaging
- IR, Vapor Phase and Wave Solder compatible
- Alignment post option keeps part from drifting during solder process
- Mates with Crane's PFF, MPFF, PLF and MPLF Series headers

STANDARD PART DIMENSIONS

INSULATOR BODY (TOP)		AFF Thru-Hole	AFF Surface Mount
W	WIDTH	0.120" / 3,05mm	0.120" / 3,05mm
H	HEIGHT	0.175" / 4,45mm	0.175" / 4,45mm
PB	Polarizing Bump Dimensions	HEIGHT	0.175" / 4,45mm
		WIDTH	0.083" / 2,10mm
		DEPTH	0.025" / 0,64mm
P1	POST DIMENSIONS	Not Applicable	0.048" / 1,22mm DIA
	REC. HOLE SIZE	Not Applicable	0.052" / 1,32mm DIA
P2	POST DIMENSIONS	Not Applicable	0.032" / 0,81mm DIA
	REC. HOLE SIZE	Not Applicable	0.036" / 0,91mm DIA
O	OVERALL	(#Pos. / 2x 0.050") + 0.015"	(#Pos. / 2x 0.050") + 0.015"
S	STANDOFF	0.005" / 0,13mm	0.005" / 0,13mm
PC TAIL (Thru-Hole Version)		AFF Thru-Hole	AFF Surface Mount
L	LENGTH	0.115" / 2,90mm	Not Applicable
C1	CENTERLINE	0.050" x 0.050" / 1,27mm x 1,27mm	Not Applicable
WIDTH & THICKNESS		0.020" / 0,51mm x 0.006" / 0,15mm	
PC TAIL (SMT Version)		AFF Thru-Hole	AFF Surface Mount
A	PAD CENTERLINE	Not Applicable	0.050" / 1,27mm
B	SPACING		0.140" / 3,56mm
C2	PAD SIZE		0.030" / 0,76mm
D	PAD SIZE		0.080" / 2,04mm
E	Alignment Post Centerline Dimension		0.060" / 1,52mm
F	Alignment Post Centerline Dimension		0.070" / 1,78mm
MATERIALS			
INSULATOR BODY		High Temperature Thermoplastic (UL94V-O)	
POST		Phosphor Bronze	

See SPECIFICATIONS and PERFORMANCE DATA for more details

THRU-HOLE VERSION (10 to 100 Positions)

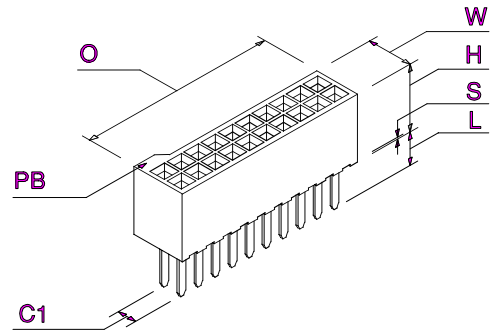

SMT VERSION (10 to 100 Positions)

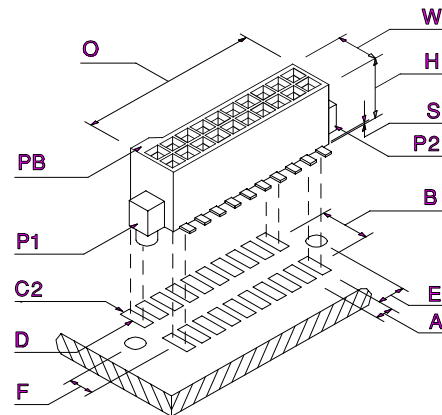

SAMPLE HOTLINE: 1-800-676-7644

0.050" (1,27mm) Centers To Mate With 0.018" (0,46mm) Posts	HOW TO ORDER CRANE'S AFF SERIES									
	STANDARD PART NUMBER									
PRODUCT SERIES	AFF				---					
NUMBER OF POSITIONS		10-100								
NUMBER OF ROWS	DUAL		D							
TYPE OF SOCKET	STRAIGHT			S						
CONTACT PLATING (See Specs Below)	G, T or F									
TAIL PLATING	SAME AS CONTACT							C		
	TIN/LEAD (USE WITH GOLD CONTACT)							T		
TAIL STYLE	STANDARD (Thru-Hole)								B	
	SURFACE MOUNT								S	
POLARIZING BUMP	Leave blank for NO bump									B
ALIGNMENT POSTS	Leave blank for no other alignment posts									A

Crane's AFF Sockets can be combined with MPLF Headers to achieve the BOARD STACKING heights noted below

SAMPLE BOARD STACKING COMBOS FOR THRU-HOLE PARTS

EXAMPLE A Crane AFF70DS-GTB Series socket used with Crane's MPLF70DS-GQ-FIH will yield a space between PC Boards of 0.500"	SOCKET STYLE	HEADER STYLE (Please Reference Crane's MPLF Web-Catalog Page)					BOARD SPACING ACHIEVED ("B")
		AFF +	MPLF	C	A	B	=
	AFF +	MPLF	D	E	F	=	0.425"
	AFF +	MPLF	F	I	H	=	0.500"
	AFF +	MPLF	D	O	N	=	0.625"

SAMPLE BOARD STACKING COMBOS FOR SURFACE MOUNT PARTS

EXAMPLE A Crane AFF70DS-GTS Series socket used with Crane's MPLF70DS-GS-JI will yield a space between PC Boards of 0.500"	SOCKET STYLE	HEADER STYLE (Please reference Crane's MPLF/SMT Web-Catalog Page)				BOARD SPACING ACHIEVED ("B")
		AFF +	MPLF / SMT	F	E	=
	AFF +	MPLF / SMT	J	I	=	0.500"
	AFF +	MPLF / SMT	C	L	=	0.550"
	AFF +	MPLF / SMT	F	O	=	0.625"

CRANE CONNECTORS - PLATING SPECIFICATIONS

PLATING OPTIONS		CONTACT AREA Inches (Millimeters)	PC TAIL Inches (Millimeters)	UNDERPLATE Inches (Millimeters)
G	Selective	15 _μ " (0,00038) Gold	100 _μ " (0,00254) Tin/Lead - Min	50 _μ " (0,00127) Nickel - Min.
T	Tin / Lead	100 _μ " (0,00254) Tin / Lead	100 _μ " (0,00254) Tin/Lead - Min	50 _μ " (0,00127) Nickel - Min.
M	Selective	50 _μ " (0,00127) Gold	100 _μ " (0,00254) Tin/Lead - Min	50 _μ " (0,00127) Nickel - Min.
H	Selective	30 _μ " (0,00076) Gold	100 _μ " (0,00254) Tin/Lead - Min	50 _μ " (0,00127) Nickel - Min.
L	Selective	10 _μ " (0,00025) Gold	100 _μ " (0,00254) Tin/Lead - Min	50 _μ " (0,00127) Nickel - Min.
F	Selective	3 _μ " (0,00008) Gold	100 _μ " (0,00254) Tin/Lead - Min	50 _μ " (0,00127) Nickel - Min.

ENGINEERING NOTE:

The information presented in this catalog page is accurate to the best of our knowledge. Due to ongoing efforts to advance design and material performance, the information is subject to change without notice.

STANDARDS

ISO9001



Crane Connectors
File No. A-3620

Registered by UL to ISO9001 under UL's accreditation by Raad voor de Certificatie (RvC), the Dutch Council for Certification.

SAMPLE HOTLINE: 1-800-676-7644

CRANE CONNECTORS • 4700 Smith Road • Cincinnati, Ohio 45212 USA • E-mail Address: info@craneconnectors.com
Phone: (513) 631-4700 • Fax (513) 631-5700 • Toll Free US (800) 676-7644 • Canada (800) 420-7310