

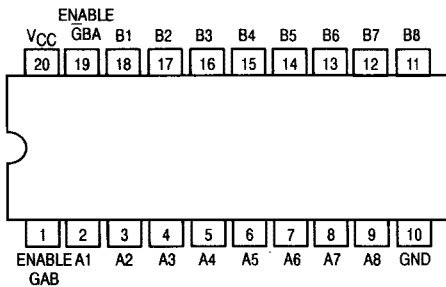

# OCTAL BUS TRANSCEIVER WITH 3-STATE OUTPUT

The SN54/74LS623 series is an octal bus transceiver designed for asynchronous two-way communication between data buses. Control function implementation allows maximum timing flexibility. Enable inputs may be used to disable the device so that buses are effectively isolated. Depending on the Logic Levels at the enable inputs, Data transmission is allowed from the A bus to the B bus or from the B bus to the A bus. The dual-enable configuration gives the LS623 the capability to store data by simultaneous enabling of GBA and GAB. Each output reinforces its input in this transceiver configuration. Thus, when both control inputs are enabled all other data sources to the two sets of bus lines (16 in all) will remain at their last states.

CONNECTION DIAGRAM (TOP VIEW)



BLOCK DIAGRAM

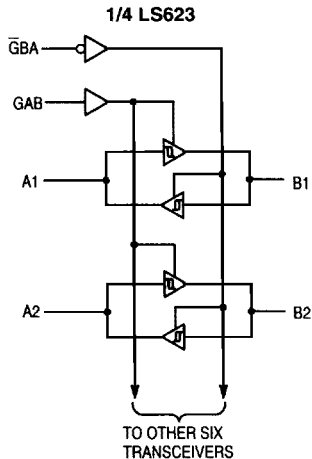

## SN54/74LS623

### OCTAL BUS TRANSCEIVER WITH 3-STATE OUTPUT LOW POWER SCHOTTKY

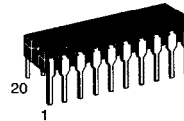

J SUFFIX  
 CERAMIC  
 CASE 732-03

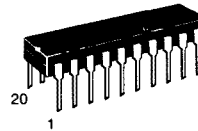

N SUFFIX  
 PLASTIC  
 CASE 738-03

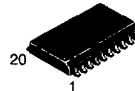

DW SUFFIX  
 SOIC  
 CASE 751D-03

ORDERING INFORMATION

SN54LSXXXJ Ceramic  
 SN74LSXXXN Plastic  
 SN74LSXXXDW SOIC

FUNCTION TABLE

ENABLE INPUTS		OPERATION
$\bar{G}BA$	GAB	LS623
L	L	B data to A bus
H	H	A data to B bus
H	L	Isolation
L	H	B data to A bus, A data to B bus

H = HIGH Level, L = LOW Level, X = Irrelevant

# SN54/74LS623

## GUARANTEED OPERATING RANGES

Symbol	Parameter		Min	Typ	Max	Unit
V <sub>CC</sub>	Supply Voltage	54 74	4.5 4.75	5.0 5.0	5.5 5.25	V
T <sub>A</sub>	Operating Ambient Temperature Range	54 74	-55 0	25 25	125 70	°C
I <sub>OH</sub>	Output Current — High	54, 74			-3.0	mA
		54 74			-12 -15	mA
I <sub>OL</sub>	Output Current — Low	54 74			12 24	mA

## DC CHARACTERISTICS OVER OPERATING TEMPERATURE RANGE (unless otherwise specified)

Symbol	Parameter	Limits			Unit	Test Conditions	
		Min	Typ	Max			
V <sub>IH</sub>	Input HIGH Voltage	2.0			V	Guaranteed Input HIGH Voltage for All Inputs	
V <sub>IL</sub>	Input LOW Voltage	54		0.5	V	Guaranteed Input LOW Voltage for All Inputs	
		74		0.6			
V <sub>T+</sub> -V <sub>T-</sub>	Hysteresis	0.2	0.4		V	V <sub>CC</sub> = MIN	
V <sub>IK</sub>	Input Clamp Diode Voltage		-0.65	-1.5	V	V <sub>CC</sub> = MIN, I <sub>IN</sub> = -18 mA	
V <sub>OH</sub>	Output HIGH Voltage	54, 74	2.4	3.4	V	V <sub>CC</sub> = MIN, I <sub>OH</sub> = -3.0 mA	
		54, 74	2.0		V	V <sub>CC</sub> = MIN, I <sub>OH</sub> = MAX	
V <sub>OL</sub>	Output LOW Voltage	54, 74		0.25	0.4	V	I <sub>OL</sub> = 12 mA
		74		0.35	0.5	V	I <sub>OL</sub> = 24 mA
						V <sub>CC</sub> = V <sub>CC</sub> MIN, V <sub>IN</sub> = V <sub>IL</sub> or V <sub>IH</sub> per Truth Table	
I <sub>OZH</sub>	Output Off Current HIGH			20	μA	V <sub>CC</sub> = MAX, V <sub>OUT</sub> = 2.7 V	
I <sub>OZL</sub>	Output Off Current LOW			-400	μA	V <sub>CC</sub> = MAX, V <sub>OUT</sub> = 4.0 V	
I <sub>IH</sub>	Input HIGH Current	A, or B, $\overline{\text{G}}\text{BA}$ or $\overline{\text{G}}\text{AB}$			20	μA	V <sub>CC</sub> = MAX, V <sub>IN</sub> = 2.7 V
		$\overline{\text{G}}\text{AB}$ or $\overline{\text{G}}\text{AB}$			0.1	mA	V <sub>CC</sub> = MAX, V <sub>IN</sub> = 7.0 V
		A or B			0.1	mA	V <sub>CC</sub> = MAX, V <sub>IN</sub> = 5.5 V
I <sub>IL</sub>	Input LOW Current			-0.4	mA	V <sub>CC</sub> = MAX, V <sub>IN</sub> = 0.4 V	
I <sub>OS</sub>	Short Circuit Current (Note 1)		-40	-225	mA	V <sub>CC</sub> = MAX	
I <sub>CC</sub>	Power Supply Current				mA	V <sub>CC</sub> = MAX	
	Total Output HIGH			70			
	Total Output LOW			90			
	Total at HIGH Z			95			

Note 1: Not more than one output should be shorted at a time, nor for more than 1 second.

# SN54/74LS623

## AC CHARACTERISTICS (T<sub>A</sub> = 25°C, V<sub>CC</sub> = 5.0 V)

Symbol	Parameter	Limits			Unit	Test Conditions
		Min	Typ	Max		
t <sub>PLH</sub> t <sub>PHL</sub>	Propagation Delay A to B		8.0 11	15 15	ns	C <sub>L</sub> = 45 pF, R <sub>L</sub> = 667 Ω
t <sub>PLH</sub> t <sub>PHL</sub>	Propagation Delay B to A		8.0 11	15 15	ns	
t <sub>PZL</sub> t <sub>PZH</sub>	Output Enable Time GBA to A		31 26	40 40	ns	
t <sub>PZL</sub> t <sub>PZH</sub>	Output Enable Time GAB to B		31 26	40 40	ns	
t <sub>PLZ</sub> t <sub>PHZ</sub>	Output Disable Time GBA to A		15 15	25 25	ns	C <sub>L</sub> = 5.0 pF
t <sub>PLZ</sub> t <sub>PHZ</sub>	Output Disable Time GAB to B		15 15	25 25	ns	