

Preliminary

1024-Bit Serial (3V to 5V) Electrically Erasable PROM
with 2V Read Capability

FEATURES

- **State-of-the-Art Architecture**
 - Nonvolatile data storage
 - 3V to 5V operation
 - Full TTL compatible inputs and outputs
 - Auto Increment for efficient data dump
- **Hardware and Software Write Protection**
 - Defaults to write-disabled state at power up
 - Software instructions for write-enable/disable
- **Low Power Consumption**
 - 1mA active (typical)
 - 1µA standby (typical)
- **Low Voltage Read Operations**
 - Reliable read operations down to 2.0 volts
- **Advanced Low Voltage CMOS E²PROM Technology**
- **Versatile, Easy-to-Use Interface**
 - Self-timed programming cycle
 - Automatic erase-before-write
 - Programming Status Indicator
 - Word and chip erasable
 - Stop SK anytime for power savings
- **Durable and Reliable**
 - 10-year data retention after 100K write cycles
 - Minimum of 100,000 write cycles per word
 - Unlimited read cycles
 - ESD protection

PIN CONFIGURATIONS

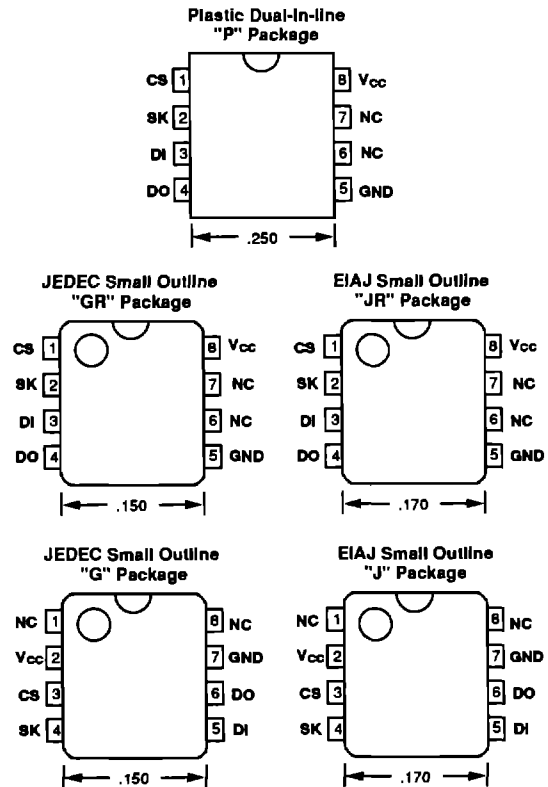

SERIAL
2
P DCTS

NOTE: The S.O. package types offer pinout options (GR & G) and (JR & J) respectively.

OVERVIEW

The XL93LC46-3 is a low cost 1024-bit, nonvolatile, serial E²PROM. It is fabricated using EXEL's advanced CMOS E²PROM technology. The XL93LC46-3 provides efficient nonvolatile read/write memory arranged as 64 registers of 16 bits each. Seven 9-bit instructions control the operation of the device, which include read, write, and mode enable functions. The data output pin (DO) indicates the status of the device during the self-timed non-volatile programming cycle.

PIN NAMES

CS	Chip Select
SK	Serial Data Clock
DI	Serial Data Input
DO	Serial Data Output
GND	Ground
Vcc	Power Supply
NC	Not Connected

BLOCK DIAGRAM

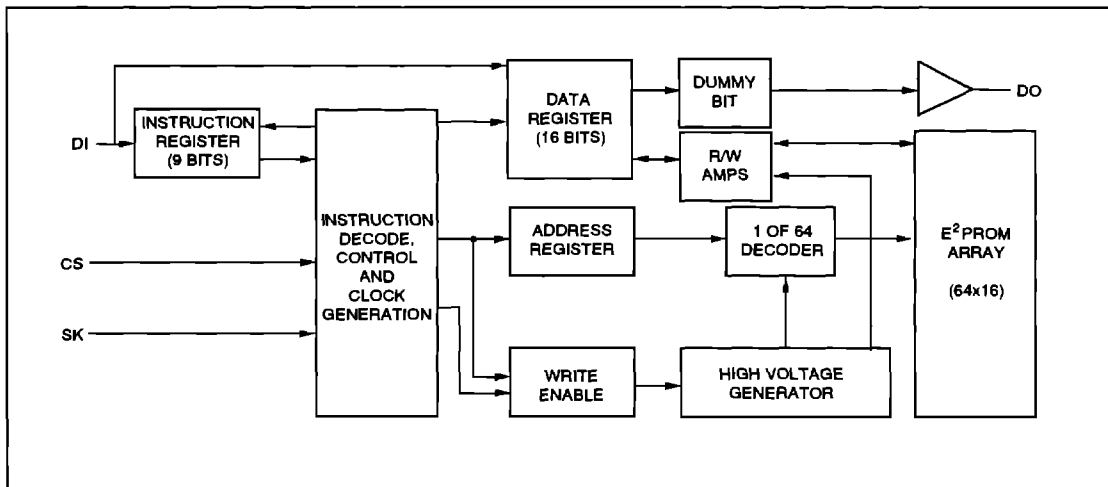

The self-timed write cycle includes an automatic erase-before-write capability. To protect against inadvertent writes, the WRITE instruction is accepted only while the chip is in the write enabled state. Data is written in 16 bits per write instruction into the selected register. If Chip Select (CS) is brought HIGH after initiation of the write cycle, the Data Output (DO) pin will indicate the READY/BUSY status of the chip.

APPLICATIONS

The XL93LC46-3 is ideal for high volume applications requiring low power and low density storage. This device uses a low cost, space saving 8-pin package. Candidate applications include robotics, alarm devices, electronic locks, meters and instrumentation settings.

ENDURANCE AND DATA RETENTION

The XL93LC46-3 is designed for applications requiring up to 100,000 write cycles per bit. It provides 10 years of secure data retention without power after the execution of 100,000 write cycles for each location.

DEVICE OPERATION

The XL93LC46-3 is controlled by seven 9-bit instructions. Instructions are clocked in (serially) on the DI pin. Each instruction begins with a logical "1" (the start bit). This is followed by the opcode (2 bits), the address field (6 bits),

and data, if appropriate. The clock signal (SK) may be halted at any time and the XL93LC46-3 will remain in its last state. This allows full static flexibility and maximum power conservation.

Read (READ)

The READ instruction is the only instruction that results in serial data on the DO pin. After the read instruction and address have been decoded, data is transferred from the selected memory register into a 16-bit serial shift register. (Please note that one logical "0" bit precedes the actual 16-bit output data string.) The output on DO changes during the low-to-high transitions of SK. (See Figure 3.)

Low Voltage Read

The XL93LC46-3 has been designed to ensure that data read operations are reliable in low voltage environments. The XL93LC46-3 is guaranteed to provide accurate data during read operations with V_{CC} as low as 2.0V. (Note: When V_{CC} falls as low as 2.0V, the maximum clock frequency is reduced to 250kHz.)

Auto Increment Read Operations

In the interest of memory transfer operation applications, the XL93LC46-3 has been designed to output a continuous stream of memory content in response to a single read operation instruction. To utilize this function, the system asserts a read instruction specifying a start location address. Once the 16 bits of the addressed word have been clocked out, the data in consecutively higher address locations is output. The address will wrap around continuously with CS HIGH until the Chip Select control pin is brought LOW. This allows for single instruction data dumps to be executed with a minimum of firmware overhead.

Write Enable (WEN)

The write enable (WEN) instruction must be executed before any device programming can be done. When V_{CC} is applied, this device powers up in the write disabled state. The device then remains in a write disabled state until a WEN instruction is executed. Thereafter the device remains enabled until a WDS instruction is executed or until V_{CC} is removed. (NOTE: Neither the WEN nor the WDS instruction has any effect on the READ instruction.) (See Figure 4.)

Write (WRITE)

The WRITE instruction includes 16 bits of data to be written into the specified register. After the last data bit has been applied to DI, and before the next rising edge of SK, CS must be brought LOW. The falling edge of CS initiates the self-timed programming cycle.

After a minimum wait of 250ns from the falling edge of CS (t_{cs}), if CS is brought HIGH, DO will indicate the READY/BUSY status of the chip: logical "0" means programming is still in progress; logical "1" means the selected register has been written, and the part is ready for another instruction. (See Figure 5.) (NOTE: The combination of CS HIGH, DI HIGH and the rising edge of the SK clock, resets the READY/BUSY flag. Therefore, it is important if you want to access the READY/BUSY flag, not to reset it through this combination of control signals.) Before a WRITE instruction can be executed, the device must be write enabled (see WEN).

Write All (WRALL)

The write all (WRALL) instruction programs all registers with the data pattern specified in the instruction.

As with the WRITE instruction, if CS is brought HIGH after a minimum wait of 250ns (t_{cs}), the DO pin indicates the READY/BUSY status of the chip. (See Figure 6.)

Write Disable (WDS)

The write disable (WDS) instruction disables all programming capabilities. This protects the entire memory array against accidental modification of data until a WEN instruction is executed. (When V_{CC} is applied, this part powers up in the write disabled state.) To protect data, a WDS instruction should be executed upon completion of each programming operation. (NOTE: Neither the WEN nor the WDS instruction has any effect on the READ instruction.) (See Figure 7.)

Erase Register

After the erase instruction is entered, CS must be brought LOW. The falling edge of CS initiates the self-timed internal programming cycle. Bringing CS HIGH after a minimum of t_{cs}, will cause DO to indicate the READY/BUSY status of the chip: a logical "0" indicates programming is still in progress; a logical "1" indicates the erase cycle is complete and the part is ready for another instruction. (See Figure 8.)

Erase All (ERAL)

Full chip erase is provided for ease of programming. Erasing the entire chip involves setting all bits in the entire memory array to a logical "1." (See Figure 9.)

INSTRUCTION SET

Instruction	Start Bit	OP Code	Address	Input Data
READ	1	10	(A5-A0)	
WEN (Write Enable)	1	00	11XXXX	
WRITE	1	01	(A5-A0)	D15-D0
WRALL (Write All Registers)	1	00	01XXXX	D15-D0
WDS (Write Disable)	1	00	00XXXX	
ERASE	1	11	(A5-A0)	
ERAL (Erase All Registers)	1	00	10XXXX	

ABSOLUTE MAXIMUM RATINGS

Temperature under bias: S93LC46	0°C to +70°C
E93LC46	-40°C to +85°C
Storage Temperature	-65°C to +125°C
Voltage with Respect to Ground	-0.3 to +6.5V

NOTE: These are STRESS ratings only. Appropriate conditions for operating these devices are given elsewhere in this specification. Stresses beyond those listed here may permanently damage the part. Prolonged exposure to maximum ratings may affect device reliability.

DC ELECTRICAL CHARACTERISTICS

TA = 0°C to +70°C or -40°C to +85°C for E93LC46-3, VCC = 3V ±10%

Symbol	Parameter	Conditions	S93LC46-3		E93LC46-3		Units
			Min	Max	Min	Max	
I _{CC}	Operating Current CMOS Input Levels	CS = V _{CC} , SK = 250KHz		2		2	mA
I _{SB}	Standby Current	CS = DI = SK = 0V		2		2	μA
I _I	Input Leakage	V _{IN} = 0V to V _{CC} (CS, SK, DI)	-1	1	-1	1	μA
I _O	Output Leakage	V _{OUT} = 0V to V _{CC} , CS = 0V	-1	1	-1	1	μA
V _{IL}	Input Low Voltage		-0.1	0.15 V _{CC}	-0.1	0.15 V _{CC}	V
V _{IH}	Input High Voltage		0.8 V _{CC}	V _{CC} +0.2	0.8 V _{CC}	V _{CC} +0.2	V
V _{OL}	Output Low Voltage	I _{OL} = 10μA CMOS		0.2		0.2	V
V _{OH}	Output High Voltage	I _{OH} = -10μA CMOS	V _{CC} -0.2		V _{CC} -0.2		V

AC ELECTRICAL CHARACTERISTICS

TA = 0°C to +70°C or -40°C to +85°C for E93LC46-3, VCC = 3V ±10%

Symbol	Parameter	Conditions	S93LC46-3		E93LC46-3		Units
			Min	Max	Min	Max	
f _{SK}	SK Clock Frequency		0	250	0	250	KHz
t _{SKH}	SK High Time		1		1		μs
t _{SKL}	SK Low Time		1		1		μs
t _{CS}	Minimum CS Low Time		1		1		μs
t _{CSS}	CS Setup Time	Relative to SK	200		200		ns
t _{DIS}	DI Setup Time	Relative to SK	400		400		ns
t _{CSH}	CS Hold Time	Relative to SK	0		0		ns
t _{DIH}	DI Hold Time	Relative to SK	400		400		ns
t _{PD1}	Output Delay to "1"	AC Test		2		2	μs
t _{PD0}	Output Delay to "0"	AC Test		2		2	μs
t _{SV}	CS to Status Valid	AC Test CL = 100pF		2		2	μs
t _{DF}	CS to DO in 3-state	CS = Low to DO = Hi-Z		400		400	ns
t _{WP}	Write Cycle Time	CS = Low to DO = Ready		20		25	ms

DC ELECTRICAL CHARACTERISTICS

TA = 0°C to +70°C or -40°C to +85°C for E93LC46-3, VCC = 5V ±10%

Symbol	Parameter	Conditions	S93LC46-3		E93LC46-3		Units
			Min	Max	Min	Max	
Icc1	Operating Current CMOS Input Levels	CS = Vcc, SK = 1MHz		2		2	mA
Icc2	Operating Current TTL Input Levels	CS = VIH, SK = 1MHz		5		5	mA
Iss	Standby Current	CS = DI = SK = 0V		2		2	µA
ILI	Input Leakage	VIN = 0V to Vcc (CS, SK, DI)	-1	1	-1	1	µA
ILO	Output Leakage	VOUT = 0V to Vcc, CS = 0V	-1	1	-1	1	µA
VIL	Input Low Voltage		-0.1	0.8	-0.1	0.8	V
VIH	Input High Voltage		2	Vcc	2	Vcc	V
VOL1	Output Low Voltage	IOL = 2.1mA TTL		0.4		0.4	V
VOH1	Output High Voltage	IOH = -400µA TTL	2.4		2.4		V
VOL2	Output Low Voltage	IOL = 10µA CMOS		0.2		0.2	V
VOH2	Output High Voltage	IOH = -10µA CMOS	Vcc-0.2		Vcc-0.2		V

AC ELECTRICAL CHARACTERISTICS

TA = 0°C to +70°C or -40°C to +85°C for E93LC46-3, VCC = 5V ±10%

Symbol	Parameter	Conditions	S93LC46-3		E93LC46-3		Units
			Min	Max	Min	Max	
fSK	SK Clock Frequency		0	1	0	1	MHz
tSKH	SK High Time		250		250		ns
tSKL	SK Low Time		250		250		ns
tCS	Minimum CS Low Time		250		250		ns
tCSS	CS Setup Time	Relative to SK	50		50		ns
tDIS	DI Setup Time	Relative to SK	100		100		ns
tCSH	CS Hold Time	Relative to SK	0		0		ns
tDIH	DI Hold Time	Relative to SK	100		100		ns
tPD1	Output Delay to "1"	AC Test		500		500	ns
tPD0	Output Delay to "0"	AC Test		500		500	ns
tSV	CS to Status Valid	AC Test CL = 100pF		500		500	ns
tDF	CS to DO in 3-state	CS = Low to DO = Hi-Z		100		100	ns
tWP	Write Cycle Time	CS = Low to DO = Ready		10		10	ms

CAPACITANCE
 $T_A = 25^\circ\text{C}$, $f = 250\text{KHz}$

Symbol	Parameter	Max	Units
C _{OUT}	Output Capacitance	5	pF
C _{IN}	Input Capacitance	5	pF

