

## LH0042 Low Cost FET Op Amp

### General Description

The LH0042 is a FET input operational amplifier with very high input impedance and low input currents with no compromise in noise, common mode rejection ratio, open loop gain, or slew rate. The LH0042 is internally compensated and is free of latch-up.

The LH0042 is specified for operation over the  $-55^{\circ}\text{C}$  to  $+125^{\circ}\text{C}$  military temperature range. The LH0042C is specified for operation over the  $-25^{\circ}\text{C}$  to  $+85^{\circ}\text{C}$  temperature range.

The LH0042 op amp is intended to fulfill a wide variety of applications for process control, medical instrumentation, and other systems requiring very low input currents. The LH0042 provides low cost high performance for such applications as electrometer and photocell amplification, picoammeters, and high input impedance buffers.

### Features

- High open loop gain—100 dB typ
- Internal compensation
- Pin compatible with standard IC op amps (TO-99 package)

### Connection Diagram

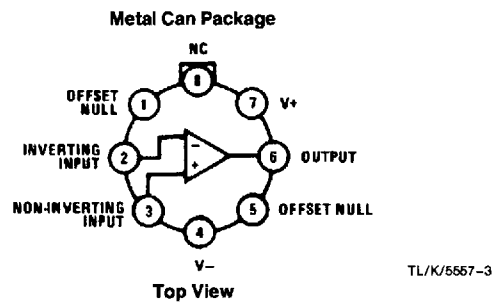

Order Number LH0042H-MIL, LH0042H or LH0042CH  
See NS Package Number H08D

## Absolute Maximum Ratings

If Military/Aerospace specified devices are required, please contact the National Semiconductor Sales Office/Distributors for availability and specifications.

Supply Voltage	±22V
Power Dissipation (see Graph)	500 mW
Input Voltage (Note 1)	±15V
Differential Input Voltage (Note 2)	±30V
Voltage Between Offset Null and V <sup>-</sup>	±0.5V

Short Circuit Duration	Continuous
Operating Temperature Range	LH0022, LH0042, LH0052 LH0022C, LH0042C, LH0052C
	-55°C to +125°C -25°C to +85°C
Storage Temperature Range	-65°C to +150°C
Lead Temperature (Soldering, 10 sec.)	300°C

## DC Electrical Characteristics for LH0022/LH0022C (Note 3) T<sub>A</sub> = T<sub>J</sub>(Max)

Parameter	Conditions	Limits						Units
		LH0022			LH0022C			
		Min	Typ	Max	Min	Typ	Max	
Input Offset Voltage	R <sub>S</sub> ≤ 100 kΩ, T <sub>A</sub> = 25°C V <sub>S</sub> = ±15V		2.0	4.0		3.5	6.0	mV
	R <sub>S</sub> ≤ 100 kΩ, V <sub>S</sub> = ±15V			5.0			7.0	mV
Temperature Coefficient of Input Offset Voltage	R <sub>S</sub> ≤ 100 kΩ		10			15		μV/°C
Offset Voltage Drift with Time			3			4		μV/week
Input Offset Current	T <sub>A</sub> = 25°C (Note 4)		0.2	2.0		1.0	5.0	pA
				2.0			0.5	nA
Temperature Coefficient of Input Offset Current		Doubles Every 10°C			Doubles Every 10°C			
Offset Current Drift with Time			0.1			0.1		pA/week
Input Bias Current	T <sub>A</sub> = 25°C (Note 4)		5	10		10	25	pA
				10			2.5	nA
Temperature Coefficient of Input Bias Current		Doubles Every 10°C			Doubles Every 10°C			
Differential Input Resistance			10 <sup>12</sup>			10 <sup>12</sup>		Ω
Common Mode Input Resistance			10 <sup>12</sup>			10 <sup>12</sup>		Ω
Input Capacitance			4.0			4.0		pF
Input Voltage Range	V <sub>S</sub> = ±15V	±12	±13.5		±12	±13.5		V
Common Mode Rejection Ratio	R <sub>S</sub> ≤ 10 kΩ, V <sub>IN</sub> = ±10V	74	90		70	90		dB
Supply Voltage Rejection Ratio	R <sub>S</sub> ≤ 10 kΩ, ±5V ≤ V <sub>S</sub> ≤ ±15V	74	90		70	90		dB
Large Signal Voltage Gain	R <sub>L</sub> = 2 kΩ, V <sub>OUT</sub> = ±10V T <sub>A</sub> = 25°C, V <sub>S</sub> = ±15V	75	100		75	100		V/mV
	R <sub>L</sub> = 2 kΩ, V <sub>OUT</sub> = ±10V V <sub>S</sub> = ±15V	30			30			V/mV
Output Voltage Swing	R <sub>L</sub> = 1 kΩ, T <sub>A</sub> = 25°C V <sub>S</sub> = ±15V	±10	±12.5		±10	±12		V
	R <sub>L</sub> = 2 kΩ, V <sub>S</sub> = ±15V	±10			±10			V
Output Current Swing	V <sub>OUT</sub> = ±10V, T <sub>A</sub> = 25°C	±10	±15		±10	±15		mA
Output Resistance			75			75		Ω
Output Short Circuit Current			25			25		mA
Supply Current	V <sub>S</sub> = ±15V		2.0	2.5		2.4	2.8	mA
Power Consumption	V <sub>S</sub> = ±15V			75			85	mW

**DC Electrical Characteristics** for LH0042/LH0042C (Note 3)

Parameter	Conditions	Limits						Units
		LH0042			LH0042C			
		Min	Typ	Max	Min	Typ	Max	
Input Offset Voltage	$R_S \leq 100 \text{ k}\Omega$		5.0	20		6.0	20	mV
Temperature Coefficient of Input Offset Voltage	$R_S \leq 100 \text{ k}\Omega$		10			15		$\mu\text{V}/^\circ\text{C}$
Offset Voltage Drift with Time			7.0			10		$\mu\text{V}/\text{week}$
Input Offset Current	$T_A = 25^\circ\text{C}$ (Note 4)		1.0	5.0		2.0	10	pA
Input Bias Current	$T_A = 25^\circ\text{C}$ (Note 4)		10	25		15	50	pA
Temperature Coefficient of Input Bias Current		Doubles Every $10^\circ\text{C}$			Doubles Every $10^\circ\text{C}$			
Differential Input Resistance			$10^{12}$			$10^{12}$		$\Omega$
Common Mode Input Resistance			$10^{12}$			$10^{12}$		$\Omega$
Input Capacitance			4.0			4.0		pF
Input Voltage Range		$\pm 12$	$\pm 13.5$		$\pm 12$	$\pm 13.5$		V
Common Mode Rejection Ratio	$R_S \leq 10 \text{ k}\Omega$ , $V_{IN} = \pm 10\text{V}$	70	86		70	80		dB
Supply Voltage Rejection Ratio	$R_S \leq 10 \text{ k}\Omega$ , $\pm 5\text{V} \leq V_S \leq \pm 15\text{V}$	70	86		70	86		dB
Large Signal Voltage Gain	$R_S \leq 2 \text{ k}\Omega$ , $V_{OUT} = \pm 10\text{V}$ , $T_A = 25^\circ\text{C}$	50	100		25	100		V/mV
	$R_S \leq 2 \text{ k}\Omega$ , $V_{OUT} = \pm 10\text{V}$	30			25			V/mV
Output Voltage Swing	$R_L = 1 \text{ k}\Omega$ , $T_A = 25^\circ\text{C}$	$\pm 10$	$\pm 12.5$		$\pm 10$	$\pm 12$		V
	$R_L = 2 \text{ k}\Omega$	$\pm 10$			$\pm 10$			V
Output Current Swing	$V_{OUT} = \pm 10\text{V}$	$\pm 10$	$\pm 15$		$\pm 10$	$\pm 15$		mA
Output Resistance			75			75		$\Omega$
Output Short Circuit Current			20			20		mA
Supply Current	$V_S = \pm 15\text{V}$		2.5	3.5		2.8	4.0	mA
Power Consumption	$V_S = \pm 15\text{V}$			105			120	mW

### DC Electrical Characteristics for LH0052/LH0052C (Note 3) (Continued)

Parameter	Conditions	Limits						Units
		LH0052			LH0052C			
		Min	Typ	Max	Min	Typ	Max	
Input Bias Current	$T_A = 25^\circ\text{C}$ (Note 4)		0.5	2.5		1.0	5.0	pA
				2.5			0.5	nA
Temperature Coefficient of Input Bias Current		Doubles Every $10^\circ\text{C}$			Doubles Every $10^\circ\text{C}$			
Differential Input Resistance			$10^{12}$			$10^{12}$		$\Omega$
Common Mode Input Resistance			$10^{12}$			$10^{12}$		$\Omega$
Input Capacitance			4.0			4.0		pF
Input Voltage Range	$V_S = \pm 15\text{V}$	$\pm 12$	$\pm 13.5$		$\pm 12$	$\pm 13.5$		V
Common Mode Rejection Ratio	$R_S \leq 10\text{ k}\Omega$ , $V_{IN} = \pm 10\text{V}$	74	90		70	90		dB
Supply Voltage Rejection Ratio	$R_S \leq 10\text{ k}\Omega$ , $\pm 5\text{V} \leq V_S \leq \pm 15\text{V}$	74	90		70	90		dB
Large Signal Voltage Gain	$R_L = 2\text{ k}\Omega$ , $V_{OUT} = \pm 10\text{V}$ $V_S = \pm 15\text{V}$ , $T_A = 25^\circ\text{C}$	75	100		75	100		V/mV
	$R_L = 2\text{ k}\Omega$ , $V_{OUT} = \pm 10\text{V}$ $V_S = \pm 15\text{V}$	30			30			V/mV
Output Voltage Swing	$R_L = 1\text{ k}\Omega$ , $T_A = 25^\circ\text{C}$ $V_S = \pm 15\text{V}$	$\pm 10$	$\pm 12.5$		$\pm 10$	$\pm 12$		V
	$R_L = 2\text{ k}\Omega$ , $V_S = \pm 15\text{V}$	$\pm 10$			$\pm 10$			V
Output Current Swing	$V_{OUT} = \pm 10\text{V}$ , $T_A = 25^\circ\text{C}$	$\pm 10$	$\pm 15$		$\pm 10$	$\pm 15$		mA
Output Resistance			75			75		$\Omega$
Output Short Circuit Current			25			25		mA
Supply Current	$V_S = \pm 15\text{V}$		3.0	3.5		3.0	3.8	mA
Power Consumption	$V_S = \pm 15\text{V}$			105			114	mW

### AC Electrical Characteristics for all amplifiers ( $T_A = 25^\circ\text{C}$ , $V_S = \pm 15\text{V}$ )

Parameter	Conditions	Limits						Units
		LH0022/42/52			LH0022C/42C/52C			
		Min	Typ	Max	Min	Typ	Max	
Slew Rate	Voltage Follower	1.5	3.0		1.0	3.0		V/ $\mu\text{s}$
Large Signal Bandwidth	Voltage Follower		40			40		kHz
Small Signal Bandwidth			1.0			1.0		MHz
Rise Time			0.3	1.5		0.3	1.5	$\mu\text{s}$
Overshoot			10	30		15	40	%
Settling Time (0.1%)	$\Delta V_{IN} = 10\text{V}$		4.5			4.5		$\mu\text{s}$
Overload Recovery			4.0			4.0		$\mu\text{s}$

## AC Electrical Characteristics for all amplifiers ( $T_A = 25^\circ\text{C}$ , $V_S = \pm 15\text{V}$ ) (Continued)

Parameter	Conditions	Limits						Units
		LH0042			LH0042C			
		Min	Typ	Max	Min	Typ	Max	
Input Noise Voltage	$R_S = 10\text{ k}\Omega$ , $f_o = 10\text{ Hz}$		150			150		nV/√Hz
	$R_S = 10\text{ k}\Omega$ , $f_o = 100\text{ Hz}$		55			55		nV/√Hz
	$R_S = 10\text{ k}\Omega$ , $f_o = 1\text{ kHz}$		35			35		nV/√Hz
	$R_S = 10\text{ k}\Omega$ , $f_o = 10\text{ kHz}$		30			30		nV/√Hz
	$BW = 10\text{ Hz to }10\text{ kHz}$ , $R_S = 10\text{ k}\Omega$		12			12		$\mu\text{Vrms}$

**Note 1:** For supply voltages less than  $\pm 15\text{V}$ , the absolute maximum input voltage is equal to the supply voltage.

**Note 2:** Rating applies for minimum source resistance of  $10\text{ k}\Omega$ , for source resistances less than  $10\text{ k}\Omega$ , maximum differential input voltage is  $\pm 5\text{V}$ .

**Note 3:** Unless otherwise specified, these specifications apply for  $\pm 5\text{V} \leq V_S \leq \pm 20\text{V}$  and  $-55^\circ\text{C} \leq T_A \leq +125^\circ\text{C}$  for the LH0042 and  $-25^\circ\text{C} \leq T_A \leq +85^\circ\text{C}$  for the LH0042C. Typical values are given for  $T_A = 25^\circ\text{C}$ .

**Note 4:** Input currents are a strong function of temperature. Due to high speed testing they are specified at a junction temperature  $T_J = 25^\circ\text{C}$ . Self heating will cause an increase in current in manual tests.  $25^\circ\text{C}$  spec is guaranteed by testing at  $125^\circ\text{C}$ .

**Note 5:** See RETS0042X for the LH0042H military specifications.

### Auxiliary Circuits (Shown for TO-99 pin out)

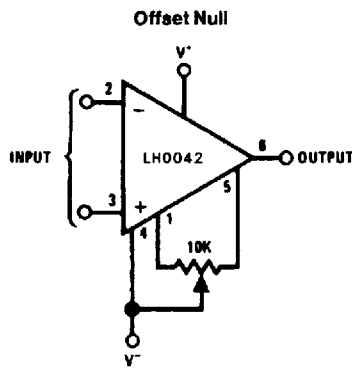

TL/K/5557-5

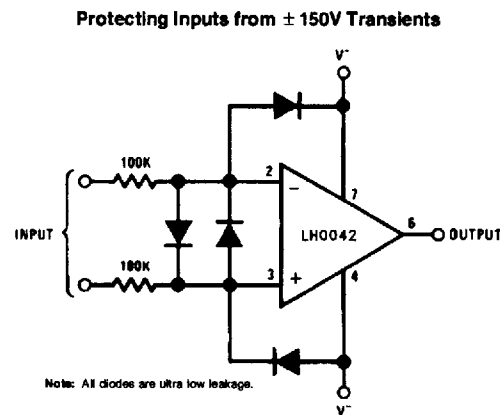

Note: All diodes are ultra low leakage.

TL/K/5557-6

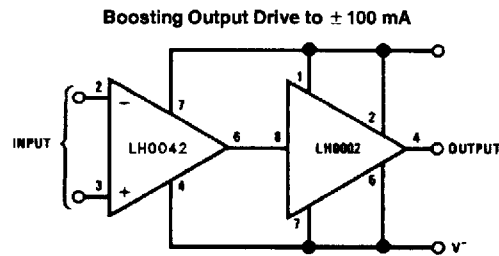

TL/K/5557-7

# Schematic Diagram

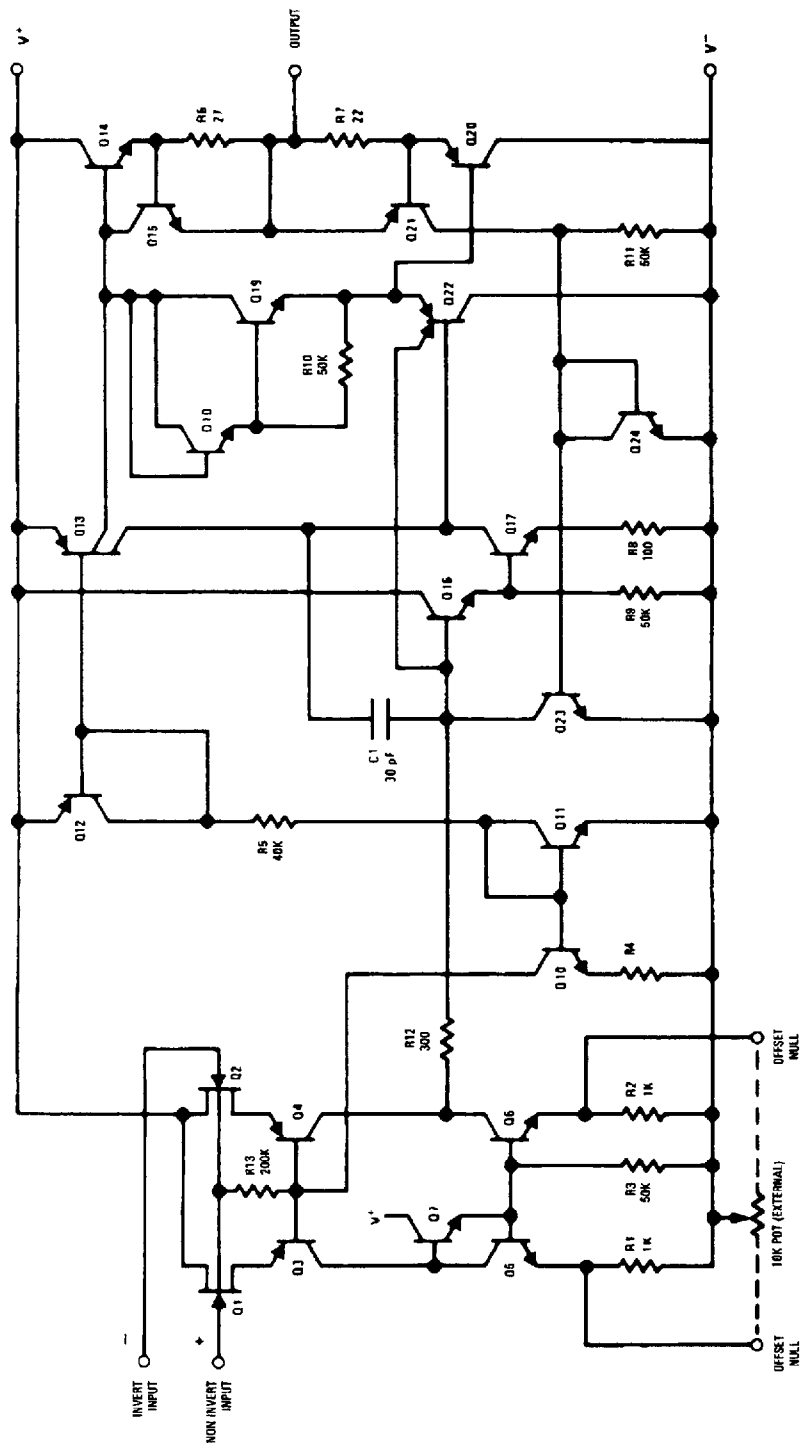

TL/K/5657-1

# Typical Applications

Precision Voltage Comparator

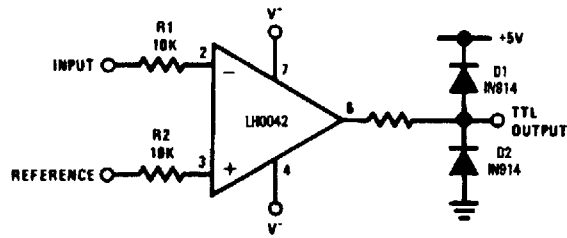

TL/K/5657-9

Subtractor for Automatic Test Gear

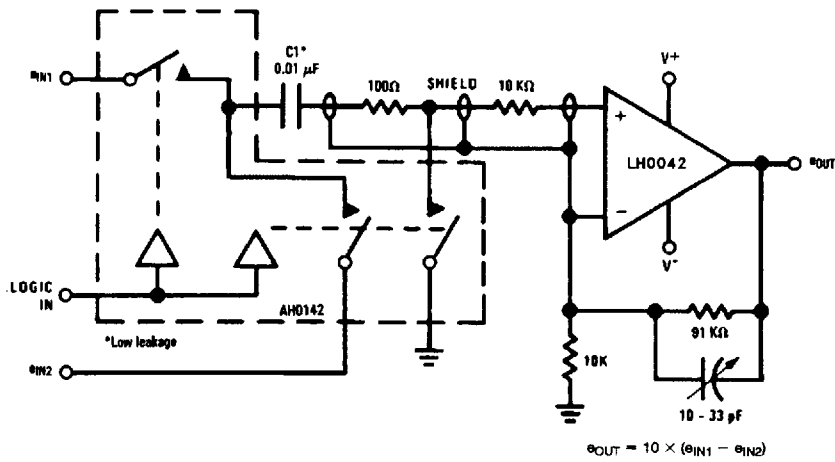

TL/K/5657-11

Sensitive Low Cost "VTVM"

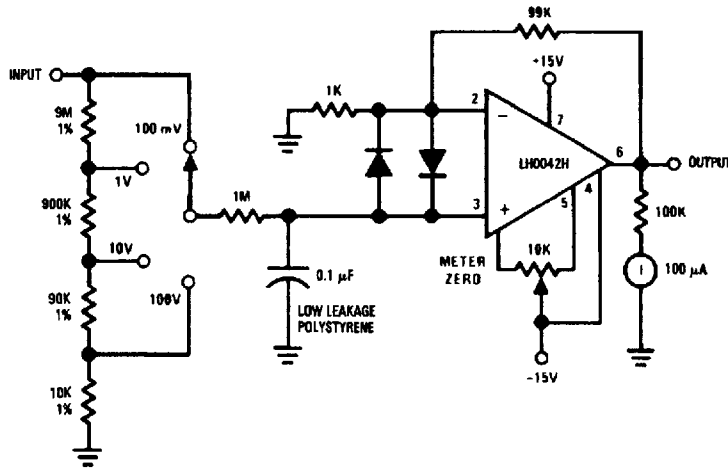

TL/K/5777-12

Typical Applications (Continued)

Ultra Low Level Current Source

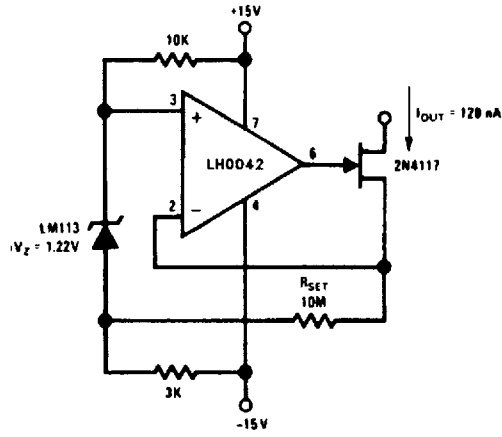

TL/K/5777-13

Sample and Hold

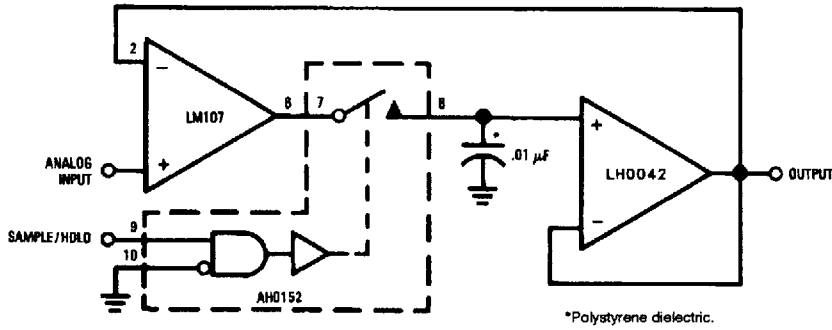

TL/K/5557-16

Re-Zeroing Amplifier

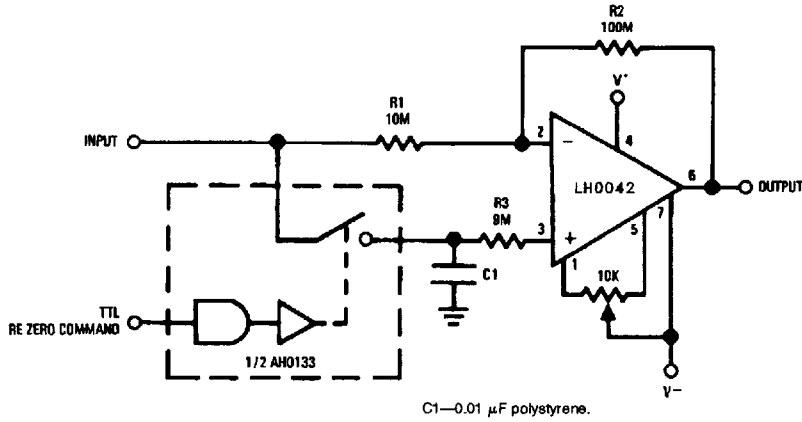

TL/K/5557-17



# Typical Performance Characteristics

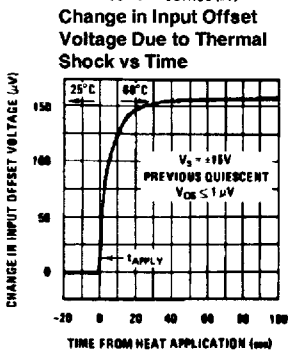
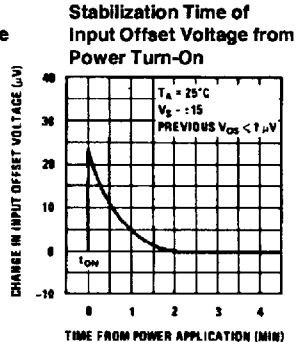
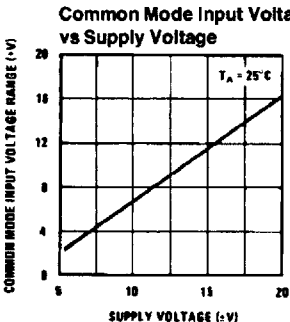
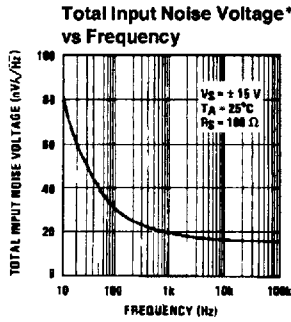
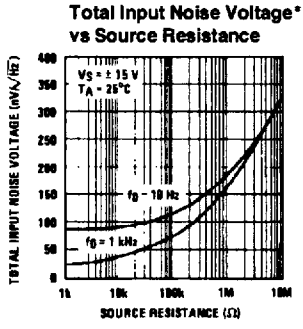
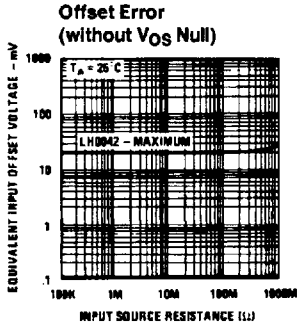
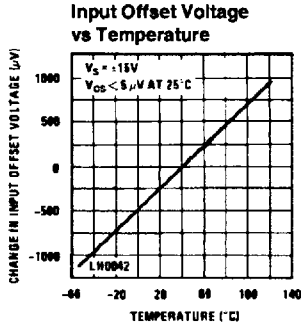
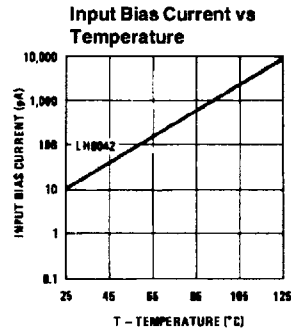
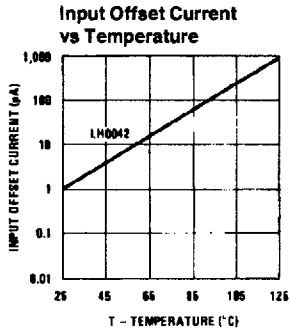
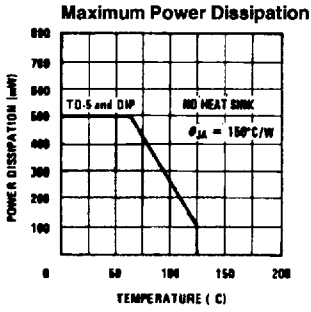

\*Noise voltage includes contribution from source resistance.

# Typical Performance Characteristics (Continued)

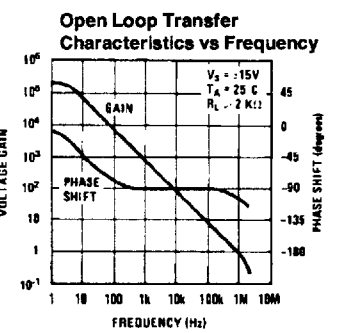
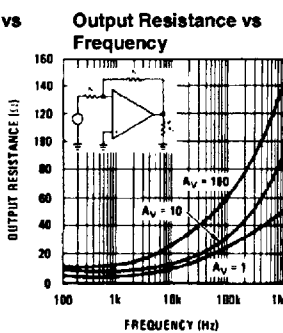
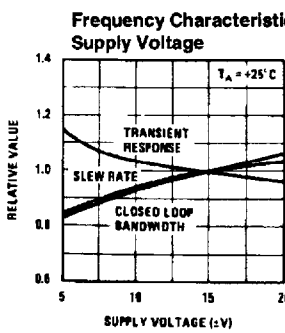
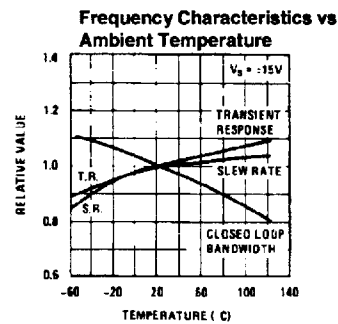
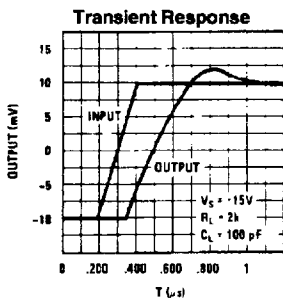
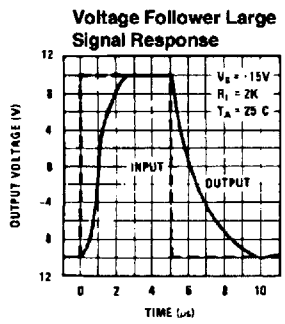
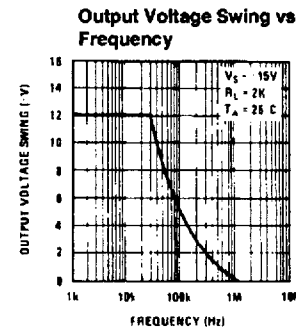
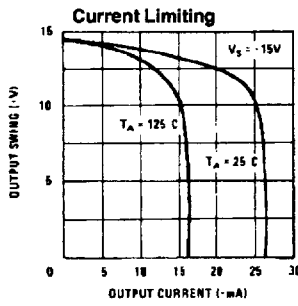
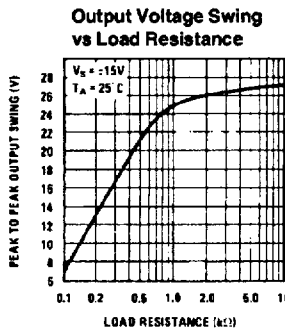
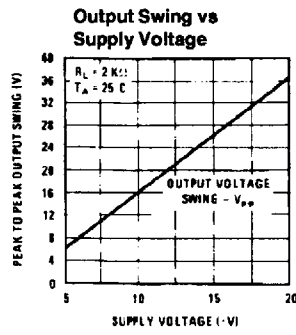
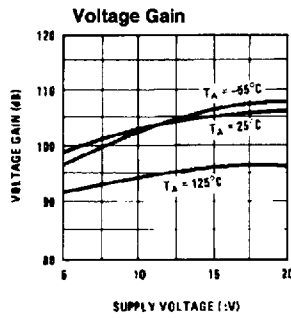
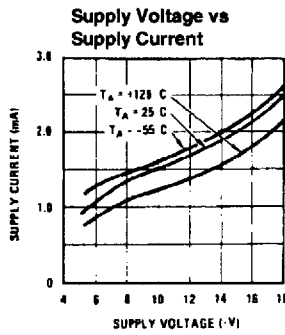

TL/K/5557-19

**Physical Dimensions** inches (millimeters)

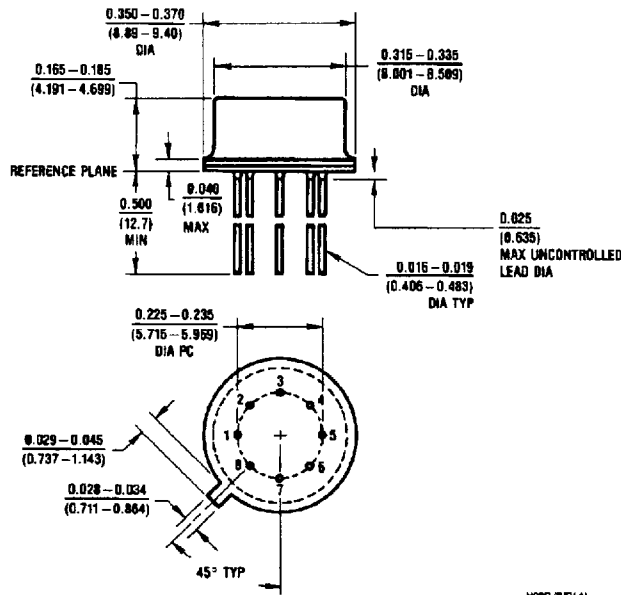

**Metal Can Package (H)**  
**Order Number H0042H-MIL, LH0042H or LH0042CH**  
**NS Package Number H08D**

**LIFE SUPPORT POLICY**

NATIONAL'S PRODUCTS ARE NOT AUTHORIZED FOR USE AS CRITICAL COMPONENTS IN LIFE SUPPORT DEVICES OR SYSTEMS WITHOUT THE EXPRESS WRITTEN APPROVAL OF THE PRESIDENT OF NATIONAL SEMICONDUCTOR CORPORATION. As used herein:

1. Life support devices or systems are devices or systems which, (a) are intended for surgical implant into the body, or (b) support or sustain life, and whose failure to perform, when properly used in accordance with instructions for use provided in the labeling, can be reasonably expected to result in a significant injury to the user.
2. A critical component is any component of a life support device or system whose failure to perform can be reasonably expected to cause the failure of the life support device or system, or to affect its safety or effectiveness.

**National Semiconductor Corporation**  
 1111 West Bardin Road  
 Arlington, TX 76017  
 Tel: 1(800) 272-9959  
 Fax: 1(800) 737-7018

**National Semiconductor Europe**  
 Fax: (+49) 0-180-530 85 86  
 Email: onjwge@1evm2.nsc.com  
 Deutsch Tel: (+49) 0-180-530 85 85  
 English Tel: (+49) 0-180-532 78 32  
 Français Tel: (+49) 0-180-532 83 58  
 Italiano Tel: (+49) 0-180-534 16 80

**National Semiconductor Hong Kong Ltd.**  
 13th Floor, Straight Block,  
 Ocean Centre, 5 Canton Rd,  
 Tsimshatsui, Kowloon  
 Hong Kong  
 Tel: (852) 2737-1800  
 Fax: (852) 2736-9960

**National Semiconductor Japan Ltd.**  
 Tel: 81-043-299-2309  
 Fax: 81-043-299-2408

National does not assume any responsibility for use of any circuitry described, no circuit patent licenses are implied and National reserves the right at any time without notice to change said circuitry and specifications.