

HD74LV373

Octal D-type Transparent Latches with 3-state Outputs

Description

The HD74LV373 has eight D type latches with three state outputs in a 20 pin package. When the latch enable input is high, the Q outputs will follow the D inputs. When the latch enable goes low, data at the D inputs will be retained at the outputs until latch enable returns high again. When a high logic level is applied to the output control input, all outputs go to a high impedance state, regardless of what signals are present at the other inputs and the state of the storage elements. Low voltage and high speed operation is suitable at the battery drive product (note type personal computer) and low power consumption extends the life of a battery for long time operation.

Features

- $V_{CC} = 2.0 \text{ V to } 5.5 \text{ V}$
- All inputs $V_{IH} (\text{Max.}) = 5.5 \text{ V} (@V_{CC} = 0 \text{ V to } 5.5 \text{ V})$
- Typical V_{OL} ground bounce $< 0.8 \text{ V} (@V_{CC} = 3.3 \text{ V}, T_a = 25^\circ\text{C})$
- Typical V_{OH} undershoot $> 2.0 \text{ V} (@V_{CC} = 3.3 \text{ V}, T_a = 25^\circ\text{C})$
- Output current $\pm 8 \text{ mA} (@V_{CC} = 3.0 \text{ V to } 3.6 \text{ V})$
 $\pm 16 \text{ mA} (@V_{CC} = 4.5 \text{ V to } 5.5 \text{ V})$

Function Table

Inputs			Output Q
\bar{G}	LE	D	
H	X	X	Z
L	H	L	L
L	H	H	H
L	L	X	Q_0

H: High level

L: Low level

X: Immaterial

Z: High impedance

Q_0 : Level of Q before the indicated steady input conditions were established.

Pin Arrangement

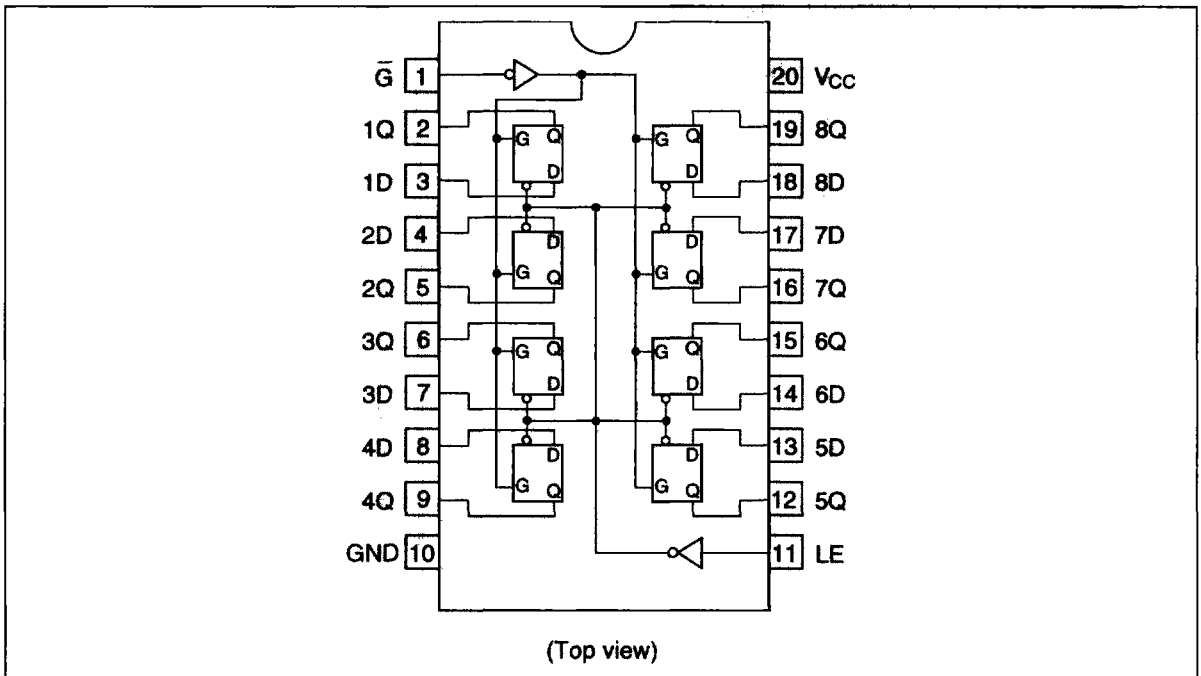

Absolute Maximum Ratings

Item	Symbol	Ratings	Unit	Conditions
Supply voltage	V_{CC}	-0.5 to 7.0	V	
Input diode current	I_{IK}	-20	mA	$V_I = -0.5$ V
Input voltage	V_I	-0.5 to 7.0	V	
Output diode current	I_{OK}	-50	mA	$V_O = -0.5$ V
		50	mA	$V_O = V_{CC} + 0.5$ V
Output voltage	V_O	-0.5 to $V_{CC} + 0.5$	V	
Output current	I_O	± 35	mA	
V_{CC} , GND current / pin	I_{CC} or I_{GND}	70	mA	
Storage temperature	T_{stg}	-65 to +150	°C	

Note: The absolute maximum ratings are values which must not individually be exceeded, and furthermore, no two of which may be realized at the same time.

Recommended Operating Conditions

Item	Symbol	Ratings	Unit	Conditions
Supply voltage	V_{CC}	2.0 to 5.5	V	
Input / output voltage	V_I	0 to 5.5	V	\bar{G} , LE, D
	V_O	0 to V_{CC}	V	Q
Operating temperature	T_a	-40 to 85	°C	
Output current	I_{OH}	-8	mA	$V_{CC} = 3.0$ V to 3.6 V
		-16 ²	mA	$V_{CC} = 4.5$ V to 5.5 V
	I_{OL}	8	mA	$V_{CC} = 3.0$ V to 3.6 V
		16 ²	mA	$V_{CC} = 4.5$ V to 5.5 V
Input rise / fall time ¹	t_r, t_f	50	ns/V	$V_{CC} = 5.5$ V
		100	ns/V	$V_{CC} = 3.6$ V

Notes: 1. This item guarantees maximum limit when one input switches.

Waveform : Refer to test circuit of switching characteristics.

2. duty cycle $\leq 50\%$

Electrical Characteristics

Item	Symbol	V_{CC} (V)	$T_a = -40$ to 85°C		Unit	Test Conditions
			Min	Max		
Input voltage	V_{IH}	2.7 to 3.6	2.0	—	V	
		4.5 to 5.5	$V_{CC} \times 0.7$	—	V	
	V_{IL}	2.7 to 3.6	—	0.8	V	
		4.5 to 5.5	—	$V_{CC} \times 0.3$	V	
Output voltage	V_{OH}	2.7 to 5.5	$V_{CC} - 0.2$	—	V	$I_{OH} = -100 \mu\text{A}$
		3.0	2.4	—	V	$I_{OH} = -8 \text{ mA}$
		4.5	3.6	—	V	$I_{OH} = -16 \text{ mA}$
	V_{OL}	2.7 to 5.5	—	0.2	V	$I_{OL} = 100 \mu\text{A}$
		3.0	—	0.4	V	$I_{OL} = 8 \text{ mA}$
		4.5	—	0.5	V	$I_{OL} = 16 \text{ mA}$
Input current	I_{IN}	0 to 5.5	—	± 1.0	μA	$V_{IN} = 5.5 \text{ V or GND}$
Off state output current	I_{OZ}	5.5	—	± 5.0	μA	$V_{IN} = V_{CC}, \text{ GND}$ $V_{OUT} = V_{CC} \text{ or GND}$
Quiescent supply current	I_{CC}	5.5	—	20	μA	$V_{IN} = V_{CC} \text{ or GND}$
	ΔI_{CC}	3.0 to 3.6	—	500	μA	$V_{IN} = \text{one input at } (V_{CC} - 0.6) \text{ V, other inputs at } V_{CC} \text{ or GND}$

HD74LV373

Switching Characteristics

Item	Symbol	V _{CC} (V)	Ta = 25°C			Ta = -40 to 85°C			Unit	From (Input)	To (Output)
			Min	Typ	Max	Min	Typ	Max			
Propagation delay time	t _{PLH}	2.7	—	10.0	15.0	1.0	—	16.5	ns	D	Q
	t _{PHL}	3.3±0.3	—	8.0	13.0	1.0	—	14.5	ns		
		5.0±0.5	—	5.5	9.5	1.0	—	10.5	ns		
	t _{PHL}	2.7	—	13.0	20.0	1.0	—	22.0	ns	LE	Q
		3.3±0.3	—	10.0	18.5	1.0	—	20.5	ns		
		5.0±0.5	—	7.5	13.5	1.0	—	15.0	ns		
Enable time	t _{ZH}	2.7	—	11.5	16.5	1.0	—	18.5	ns	\bar{G}	Q
	t _{ZL}	3.3±0.3	—	8.5	14.5	1.0	—	16.0	ns		
		5.0±0.5	—	6.5	10.5	1.0	—	11.5	ns		
Disable time	t _{HZ}	2.7	—	9.0	14.5	1.0	—	16.0	ns	\bar{G}	Q
	t _{LZ}	3.3±0.3	—	8.0	13.0	1.0	—	14.5	ns		
		5.0±0.5	—	6.0	10.0	1.0	—	11.0	ns		
Setup time	t _{su}	2.7	3.0	—	—	3.0	—	—	ns		
		3.3±0.3	3.0	—	—	3.0	—	—	ns		
		5.0±0.5	3.0	—	—	3.0	—	—	ns		
Hold time	t _h	2.7	5.0	—	—	5.0	—	—	ns		
		3.3±0.3	5.0	—	—	5.0	—	—	ns		
		5.0±0.5	5.0	—	—	5.0	—	—	ns		
Pulse width	t _w	2.7	6.0	—	—	6.0	—	—	ns		
		3.3±0.3	5.0	—	—	5.0	—	—	ns		
		5.0±0.5	5.0	—	—	5.0	—	—	ns		
Input capacitance	C _{IN}	3.3±0.3	—	—	—	—	—	2.5	pF		
Output capacitance	C _O	3.3±0.3	—	—	—	—	—	7.0	pF		

Test Circuit

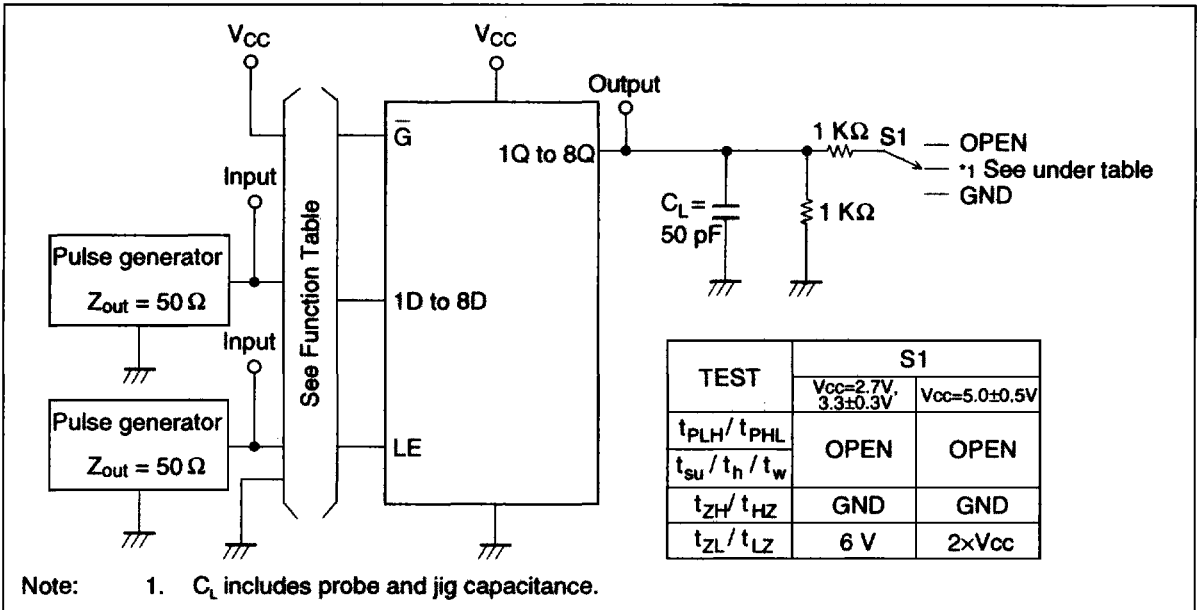

Waveforms-1

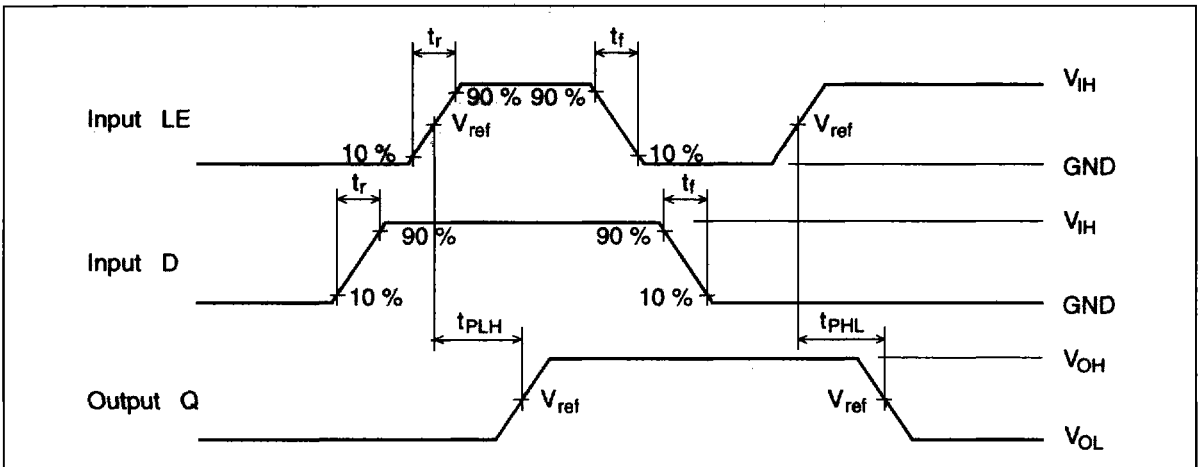

HD74LV373

Waveforms-2

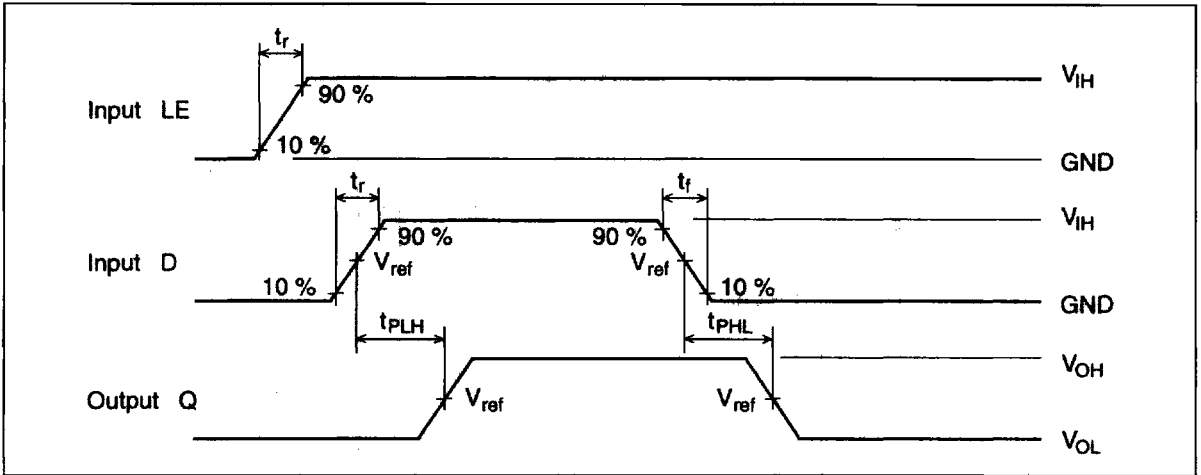

Waveforms-3

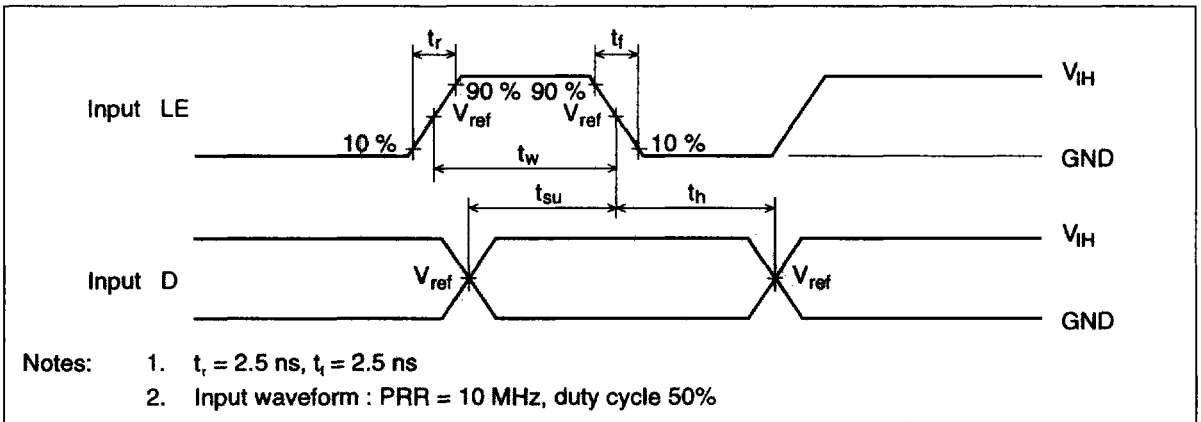

Waveforms-4

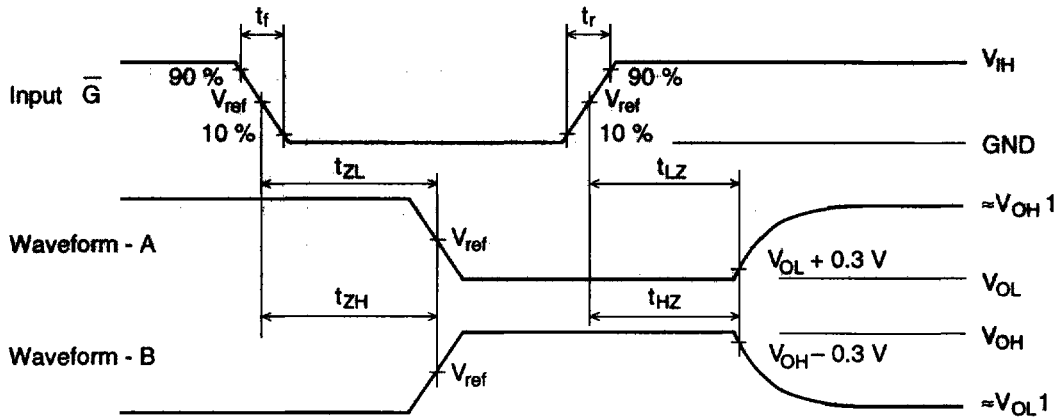

Symbol	Vcc=2.7V, 3.3±0.3V	Vcc=5.0V±0.5V
V_{IH}	2.7 V	VCC
V_{ref}	1.5 V	50%VCC
V_{OH1}	3 V	VCC
V_{OL1}	GND	GND

- Notes:
1. $t_r = 2.5$ ns, $t_f = 2.5$ ns
 2. Input waveform : PRR = 10 MHz, duty cycle 50%
 3. Waveform - A shows input conditions such that the output is "L" level when enable by the output control.
 4. Waveform - B shows input conditions such that the output is "H" level when enable by the output control.