



## Current Mode PWM Controller

### FEATURES

- Automatic Feed Forward Compensation
- Programmable Pulse-by-Pulse Current Limiting
- Automatic Symmetry Correction in Push-pull Configuration
- Enhanced Load Response Characteristics
- Parallel Operation Capability for Modular Power Systems
- Differential Current Sense Amplifier with Wide Common Mode Range
- Double Pulse Suppression
- 500mA (Peak) Totem-pole Outputs
- $\pm 1\%$  Bandgap Reference
- Under-voltage Lockout
- Soft Start Capability
- Shutdown Terminal
- 500kHz Operation

### DESCRIPTION

The UC1846/7 family of control ICs provides all of the necessary features to implement fixed frequency, current mode control schemes while maintaining a minimum external parts count. The superior performance of this technique can be measured in improved line regulation, enhanced load response characteristics, and a simpler, easier-to-design control loop. Topological advantages include inherent pulse-by-pulse current limiting capability, automatic symmetry correction for push-pull converters, and the ability to parallel "power modules" while maintaining equal current sharing.

Protection circuitry includes built-in under-voltage lockout and programmable current limit in addition to soft start capability. A shutdown function is also available which can initiate either a complete shutdown with automatic restart or latch the supply off.

Other features include fully latched operation, double pulse suppression, deadline adjust capability, and a  $\pm 1\%$  trimmed bandgap reference.

The UC1846 features low outputs in the OFF state, while the UC1847 features high outputs in the OFF state.

### BLOCK DIAGRAM

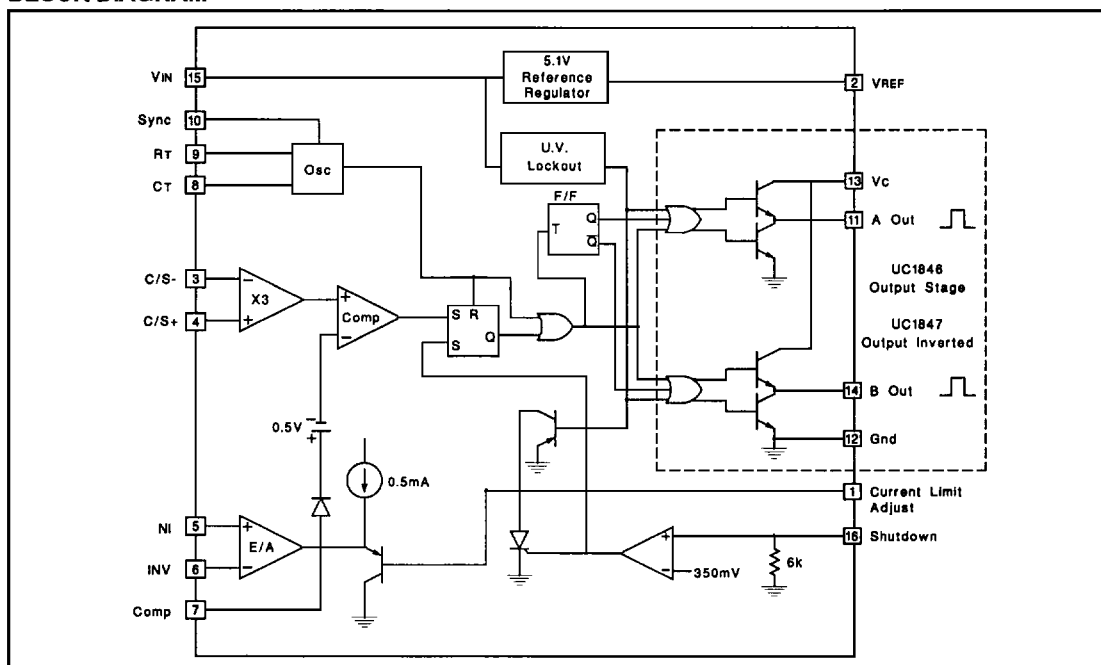

**ABSOLUTE MAXIMUM RATINGS (Note 1)**

Supply Voltage (Pin 15)	+40V
Collector Supply Voltage (Pin 13)	+40V
Output Current, Source or Sink (Pins 11, 14)	500mA
Analog Inputs (Pins 3, 4, 5, 6, 16)	-0.3V to +V <sub>IN</sub>
Reference Output Current (Pin 2)	-30mA
Sync Output Current (Pin 10)	-5mA
Error Amplifier Output Current (Pin 7)	-5mA
Soft Start Sink Current (Pin 1)	50mA
Oscillator Charging Current (Pin 9)	5mA
Power Dissipation at T <sub>A</sub> =25°C	1000mW
Power Dissipation at T <sub>C</sub> =25°C	2000mW
Storage Temperature Range	-65°C to +150°C
Lead Temperature (soldering, 10 seconds)	+300°C

Note 1. All voltages are with respect to Ground, Pin 13. Currents are positive into, negative out of the specified terminal. Consult Packaging Section of Databook for thermal limitations and considerations of packages. Pin numbers refer to DIL and SOIC packages only.

**CONNECTION DIAGRAMS**

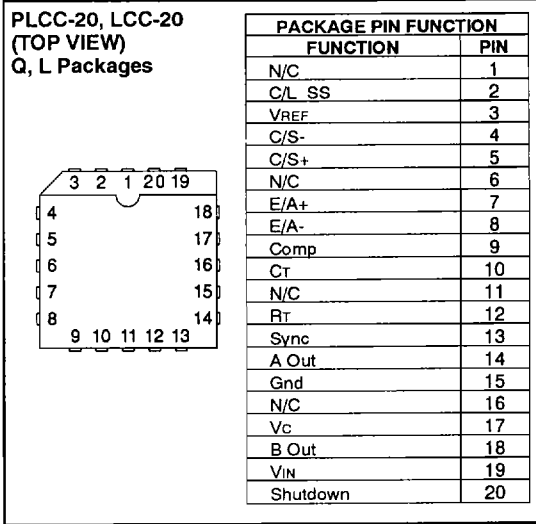
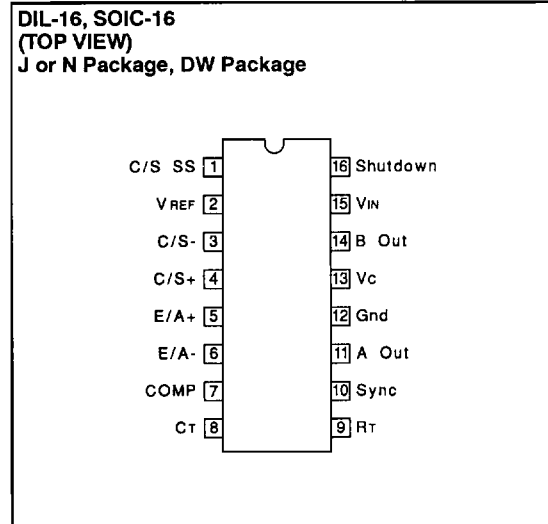

**ELECTRICAL CHARACTERISTICS** (Unless otherwise stated, these specifications apply for T<sub>A</sub>=-55°C to +125°C for UC1846/7; -40°C to +85°C for the UC2846/7; and 0°C to +70°C for the UC3846/7; V<sub>IN</sub>=15V, R<sub>T</sub>=10k, C<sub>T</sub>=4.7nF, T<sub>A</sub>=T<sub>J</sub>.)

PARAMETER	TEST CONDITIONS	UC1846/UC1847 UC2846/UC2847			UC3846/UC3847			UNITS
		MIN.	TYP.	MAX.	MIN.	TYP.	MAX.	
<b>Reference Section</b>								
Output Voltage	T <sub>J</sub> =25°C, I <sub>o</sub> =1mA	5.05	5.10	5.15	5.00	5.10	5.20	V
Line Regulation	V <sub>IN</sub> =8V to 40V		5	20		5	20	mV
Load Regulation	I <sub>L</sub> =1mA to 10mA		3	15		3	15	mV
Temperature Stability	Over Operating Range, (Note 2)		0.4			0.4		mV/°C
Total Output Variation	Line, Load, and Temperature (Note 2)	5.00		5.20	4.95		5.25	V
Output Noise Voltage	10Hz ≤ f ≤ 10kHz, T <sub>J</sub> =25°C (Note 2)		100			100		μV
Long Term Stability	T <sub>J</sub> =125°C, 1000 Hrs. (Note 2)		5			5		mV
Short Circuit Output Current	VREF=0V	-10	-45		-10	-45		mA

**ELECTRICAL CHARACTERISTICS (cont.)**

(Unless otherwise stated, these specifications apply for  $T_A = -55^\circ\text{C}$  to  $+125^\circ\text{C}$  for UC1846/7;  $-40^\circ\text{C}$  to  $+85^\circ\text{C}$  for the UC2846/7; and  $0^\circ\text{C}$  to  $+70^\circ\text{C}$  for the UC3846/7;  $V_{IN} = 15\text{V}$ ,  $R_T = 10\text{k}$ ,  $C_T = 4.7\text{nF}$ ,  $T_A = T_J$ .)

PARAMETER	TEST CONDITIONS	UC1846/UC1847 UC2846/UC2847			UC3846/UC3847			UNITS
		MIN.	TYP.	MAX.	MIN.	TYP.	MAX.	
<b>Oscillator Section</b>								
Initial Accuracy	$T_J = 25^\circ\text{C}$	39	43	47	39	43	47	kHz
Voltage Stability	$V_{IN} = 8\text{V}$ to $40\text{V}$		-1	2		-1	2	%
Temperature Stability	Over Operating Range (Note 2)		-1			-1		%
Sync Output High Level		3.9	4.35		3.9	4.35		V
Sync Output Low Level			2.3	2.5		2.3	2.5	V
Sync Input High Level	Pin 8=0V	3.9			3.9			V
Sync Input Low Level	Pin 8=0V			2.5			2.5	V
Sync Input Current	Sync Voltage=3.9V, Pin 8=0V		1.3	1.5		1.3	1.5	mA
<b>Error Amp Section</b>								
Input Offset Voltage			0.5	5		0.5	10	mV
Input Bias Current			-0.6	-1		-0.6	-2	$\mu\text{A}$
Input Offset Current			40	250		40	250	nA
Common Mode Range	$V_{IN} = 8\text{V}$ to $40\text{V}$	0		$V_{IN} - 2\text{V}$	0		$V_{IN} - 2\text{V}$	V
Open Loop Voltage Gain	$\Delta V_O = 1.2$ to $3\text{V}$ , $V_{CM} = 2\text{V}$	80	105		80	105		dB
Unity Gain Bandwidth	$T_J = 25^\circ\text{C}$ (Note 2)	0.7	1.0		0.7	1.0		MHz
CMRR	$V_{CM} = 0\text{V}$ to $38\text{V}$ , $V_{IN} = 40\text{V}$	75	100		75	100		dB
PSRR	$V_{IN} = 8\text{V}$ to $40\text{V}$	80	105		80	105		dB
Output Sink Current	$V_{ID} = -15\text{mV}$ to $-5\text{V}$ , $V_{PIN 7} = 1.2\text{V}$	2	6		2	6		mA
Output Source Current	$V_{ID} = 15\text{mV}$ to $5\text{V}$ , $V_{PIN 7} = 2.5\text{V}$	-0.4	-0.5		-0.4	-0.5		mA
High Level Output Voltage	$R_L = (\text{Pin } 7) 15\text{k}\Omega$	4.3	4.6		4.3	4.6		V
Low Level Output Voltage			0.7	1		0.7	1	V
<b>Current Sense Amplifier Section</b>								
Amplifier Gain	$V_{PIN 3} = 0\text{V}$ , Pin 1 Open (Notes 3 & 4)	2.5	2.75	3.0	2.5	2.75	3.0	V
Maximum Differential Input Signal ( $V_{PIN 4} - V_{PIN 3}$ )	Pin 1 Open (Note 3) $R_L (\text{Pin } 7) = 15\text{k}\Omega$	1.1	1.2		1.1	1.2		V
Input Offset Voltage	$V_{PIN 1} = 0.5\text{V}$ , Pin 7 Open (Note 3)		5	25		5	25	mV
CMRR	$V_{CM} = 1\text{V}$ to $12\text{V}$	60	83		60	83		dB
PSRR	$V_{IN} = 8\text{V}$ to $40\text{V}$	60	84		60	84		dB
Input Bias Current	$V_{PIN 1} = 0.5\text{V}$ , Pin 7 Open (Note 3)		-2.5	-10		-2.5	-10	$\mu\text{A}$
Input Offset Current	$V_{PIN 1} = 0.5\text{V}$ , Pin 7 Open (Note 3)		0.08	1		0.08	1	$\mu\text{A}$
Input Common Mode Range		0		$V_{IN} - 3$	0		$V_{IN} - 3$	V
Delay to Outputs	$T_J = 25^\circ\text{C}$ , (Note 2)		200	500		200	500	ns
<b>Current Limit Adjust Section</b>								
Current Limit Offset	$V_{PIN 3} = 0\text{V}$ , $V_{PIN 4} = 0\text{V}$ , Pin 7 Open (Note 3)	0.45	0.5	0.55	0.45	0.5	0.55	V
Input Bias Current	$V_{PIN 5} = V_{REF}$ , $V_{PIN 6} = 0\text{V}$		-10	-30		-10	-30	$\mu\text{A}$
<b>Shutdown Terminal Section</b>								
Threshold Voltage		250	350	400	250	350	400	mV
Input Voltage Range		0		$V_{IN}$	0		$V_{IN}$	V
Minimum Latching Current (IPIN 1)	(Note 6)	3.0	1.5		3.0	1.5		mA

**ELECTRICAL CHARACTERISTICS (cont.)**

(Unless otherwise stated, these specifications apply for TA=-55°C to +125°C for UC1846/7; -40°C to +85°C for the UC2846/7; and 0°C to +70°C for the UC3846/7; VIN=15V, RT=10k, CT=4.7nF, TA=TJ.)

PARAMETER	TEST CONDITIONS	UC1846/UC1847 UC2846/UC2847			UC3846/UC3847			UNITS
		MIN.	TYP.	MAX.	MIN.	TYP.	MAX.	
		<b>Shutdown Terminal Section (cont.)</b>						
Maximum Non-Latching Current (IPN 1)	(Note 7)		1.5	0.8		1.5	0.8	mA
Delay to Outputs	TJ=25°C (Note 2)		300	600		300	600	ns
<b>Output Section</b>								
Collector-Emitter Voltage		40			40			V
Collector Leakage Current	VC=40V (Note 5)			200			200	µA
Output Low Level	ISINK=20mA		0.1	0.4		0.1	0.4	V
	ISINK=100mA		0.4	2.1		0.4	2.1	V
Output High Level	ISOURCE=20mA	13	13.5		13	13.5		V
	ISOURCE=100mA	12	13.5		12	13.5		V
Rise Time	CL=1nF, TJ=25°C (Note 2)		50	300		50	300	ns
Fall Time	CL=1nF, TJ=25°C (Note 2)		50	300		50	300	ns
<b>Under-Voltage Lockout Section</b>								
Start-Up Threshold			7.7	8.0		7.7	8.0	V
Threshold Hysteresis			0.75			0.75		V
<b>Total Standby Current</b>								
Supply Current			17	21		17	21	mA

Note 2. These parameters, although guaranteed over the recommended operating conditions, are not 100% tested in production.

Note 3. Parameter measured at trip point of latch with VPIN 5 = VREF, VPIN 6 = 0V.

Note 4. Amplifier gain defined as:  $G = \frac{\Delta VPIN 7}{\Delta VPIN 4}$ ;  $\Delta VPIN 4 = 0$  to 1.0V.

Note 5. Applies to UC1846/UC2846/UC3846 only due to polarity of outputs.

Note 6. Current into Pin 1 guaranteed to latch circuit in shutdown state.

Note 7. Current into Pin 1 guaranteed not to latch circuit in shutdown state.

**APPLICATIONS DATA**

**Oscillator Circuit**

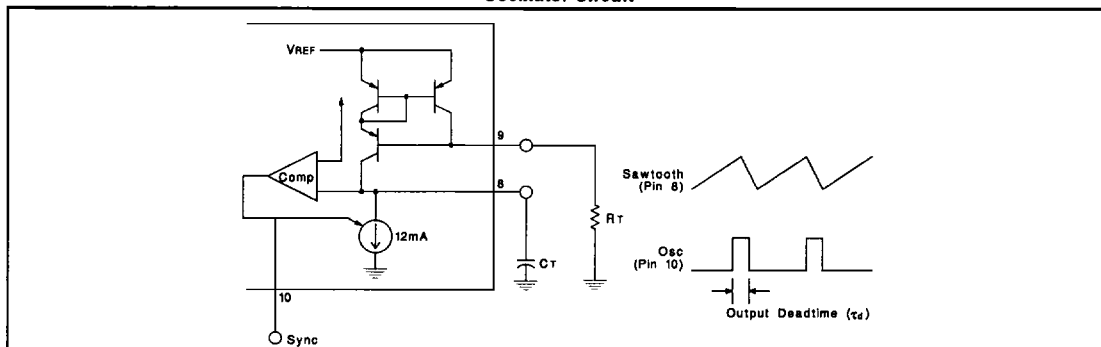

Output deadtime is determined by the external capacitor, CT, according to the formula:  $\tau_d (\mu s) = 145CT (\mu f) \left( \frac{12}{12 - \frac{3.6}{RT (k\Omega)}} \right)$ .

For large values of RT:  $\tau_d (\mu s) \approx 145CT (\mu f)$ .

Oscillator frequency is approximated by the formula:  $f_r (kHz) \approx \frac{2.2}{RT (k\Omega) \cdot CT (\mu f)}$ .

APPLICATIONS DATA (cont.)

Error Amp Output Configuration

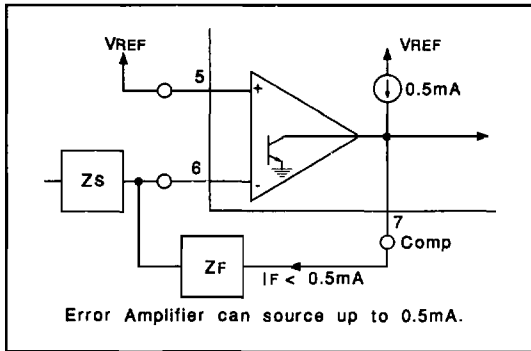

Error Amp Gain and Phase vs Frequency

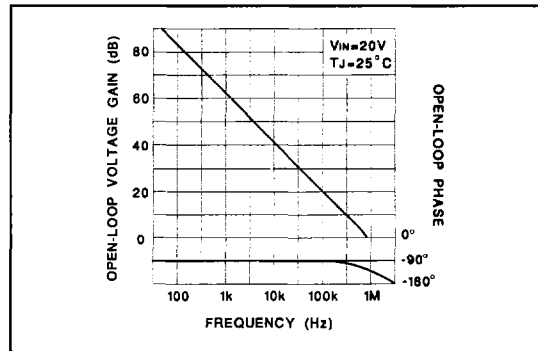

Error Amp Open-Logic D.C. Gain vs Load Resistance

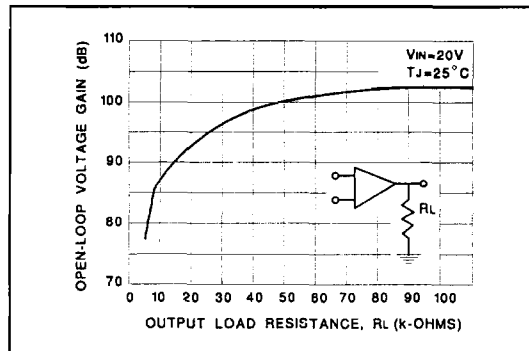

Parallel Operation

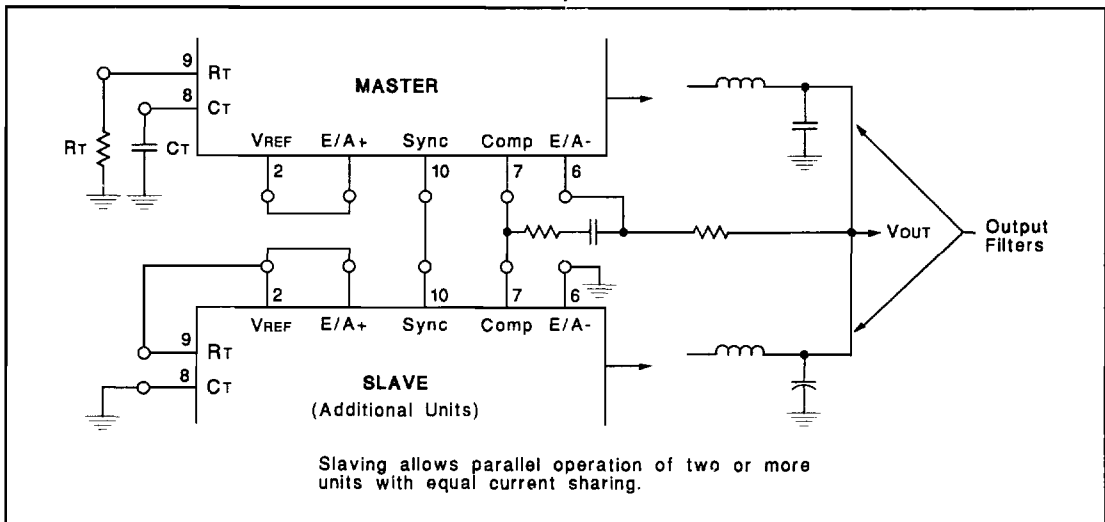

APPLICATIONS DATA (cont.)

Pulse by Pulse Current Limiting

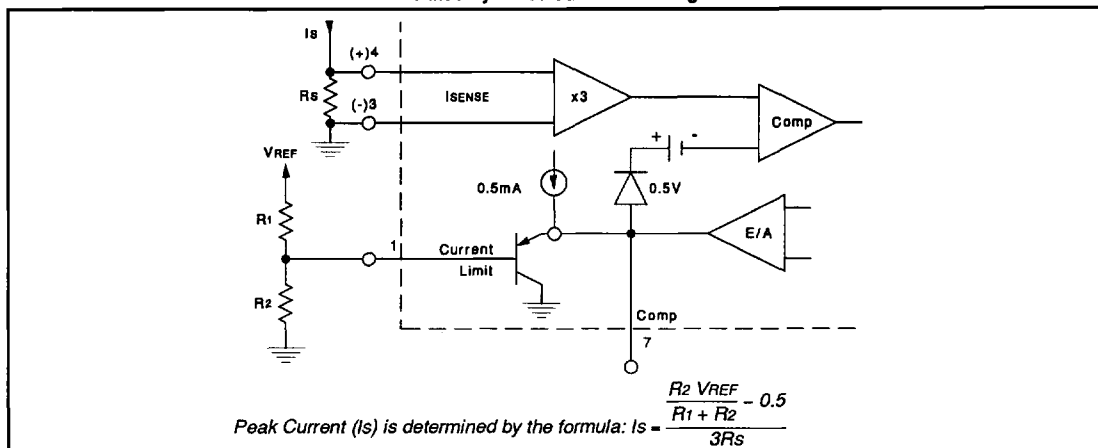

Soft Start and Shutdown /Restart Functions

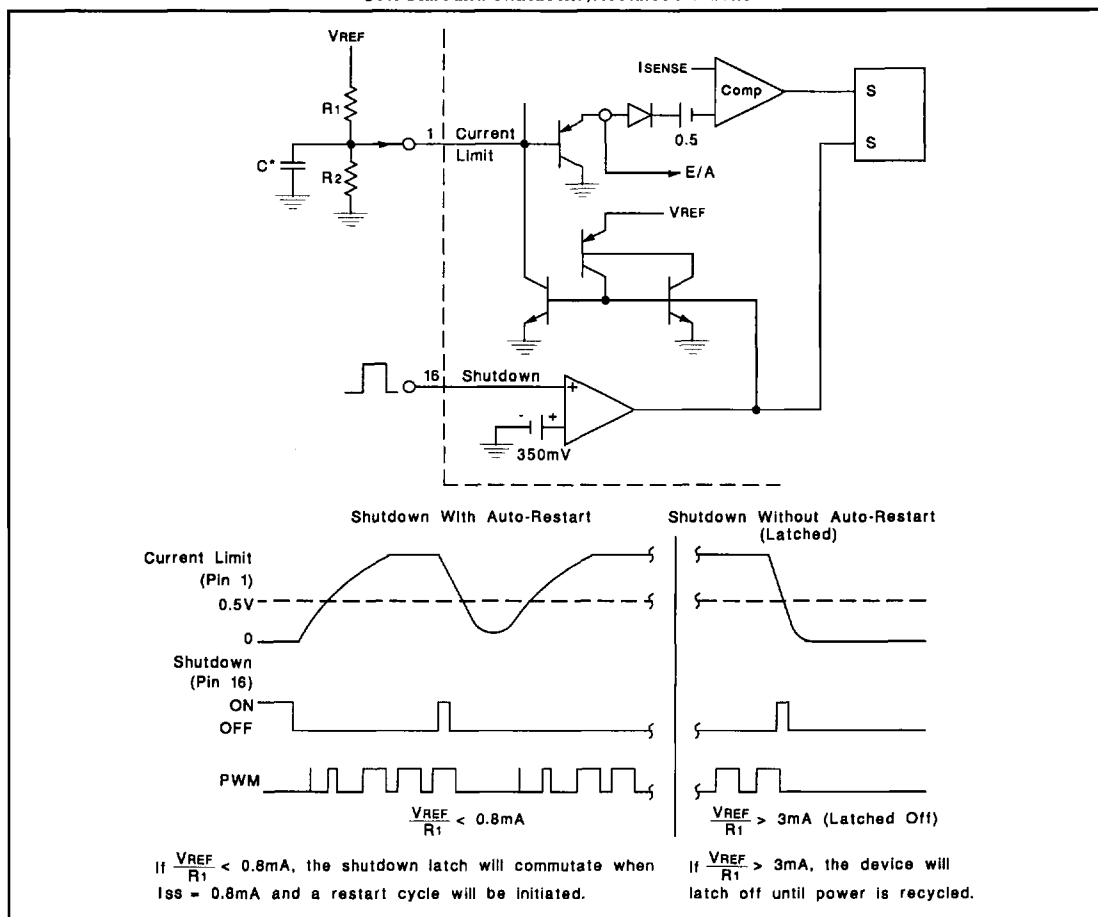

APPLICATIONS DATA (cont.)

Current Sense Amp Connection

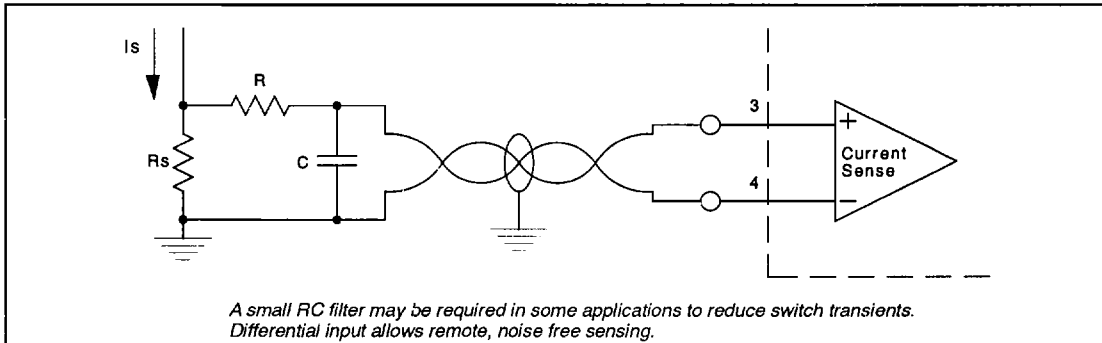

UC1846 Open Loop Test Circuit

