

National Semiconductor is now part of
Texas Instruments.

Search <http://www.ti.com/> for the latest technical
information and details on our current products and services.



NATL SEMICOND (LINEAR)

T-79-05-10

LM101A/LM201A/LM301A Operational Amplifiers

General Description

The LM101A series are general purpose operational amplifiers which feature improved performance over industry standards like the LM709. Advanced processing techniques make possible an order of magnitude reduction in input currents, and a redesign of the biasing circuitry reduces the temperature drift of input current. Improved specifications include:

- Offset voltage 3 mV maximum over temperature (LM101A/LM201A)
- Input current 100 nA maximum over temperature (LM101A/LM201A)
- Offset current 20 nA maximum over temperature (LM101A/LM201A)
- Guaranteed drift characteristics
- Offsets guaranteed over entire common mode and supply voltage ranges
- Slew rate of $10V/\mu s$ as a summing amplifier

This amplifier offers many features which make its application nearly foolproof: overload protection on the input and output, no latch-up when the common mode range is ex-

ceeded, and freedom from oscillations and compensation with a single 30 pF capacitor. It has advantages over internally compensated amplifiers in that the frequency compensation can be tailored to the particular application. For example, in low frequency circuits it can be overcompensated for increased stability margin. Or the compensation can be optimized to give more than a factor of ten improvement in high frequency performance for most applications.

In addition, the device provides better accuracy and lower noise in high impedance circuitry. The low input currents also make it particularly well suited for long interval integrators or timers, sample and hold circuits and low frequency waveform generators. Further, replacing circuits where matched transistor pairs buffer the inputs of conventional IC op amps, it can give lower offset voltage and a drift at a lower cost.

The LM101A is guaranteed over a temperature range of $-55^{\circ}C$ to $+125^{\circ}C$, the LM201A from $-25^{\circ}C$ to $+85^{\circ}C$, and the LM301A from $0^{\circ}C$ to $+70^{\circ}C$.

Connection Diagrams (Top View)

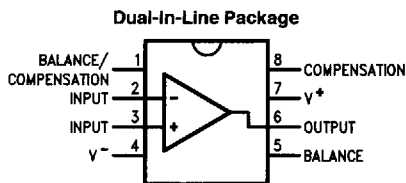

TL/H/7752-4

Order Number LM101AJ, LM101J/883*,
LM301AJ, LM201AJ or LM301AJ
See NS Package Number J08A or N08A

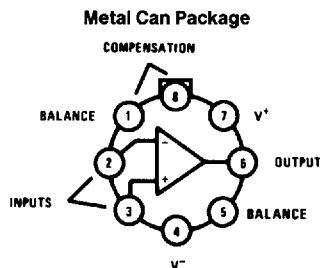

TL/H/7752-2

Note: Pin 4 connected to case.
Order Number LM101AH,
LM101AH/883*, LM201AH or LM301AH
See NS Package Number H08C

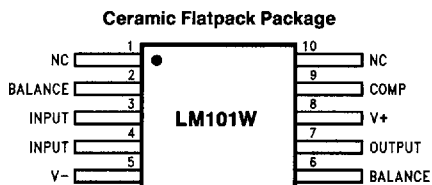

TL/H/7752-4

Order Number LM101AW/883 or LM101W/883
See NS Package Number W10A

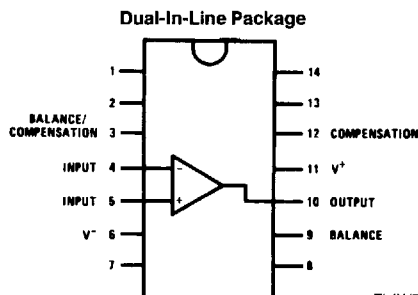

TL/H/7752-3

Order Number LM101AJ-14/883*
See NS Package Number J14A

*Available per JM38510/10103.

Absolute Maximum Ratings**NATL SEMICOND (LINEAR)**

If Military/Aerospace specified devices are required, please contact the National Semiconductor Sales Office/Distributors for availability and specifications.

	LM101A/LM201A	LM301A
Supply Voltage	±22V	±18V
Differential Input Voltage	±30V	±30V
Input Voltage (Note 1)	±15V	±15V
Output Short Circuit Duration (Note 2)	Continuous	Continuous
Operating Ambient Temp. Range	-55°C to +125°C (LM101A) -25°C to +85°C (LM201A)	0°C to +70°C
T_J Max		
H-Package	150°C	100°C
N-Package	150°C	100°C
J-Package	150°C	100°C
Power Dissipation at T_A = 25°C		
H-Package (Still Air)	500 mW	300 mW
(400 LF/Min Air Flow)	1200 mW	700 mW
N-Package	900 mW	500 mW
J-Package	1000 mW	650 mW
Thermal Resistance (Typical) θ_{jA}		
H-Package (Still Air)	165°C/W	165°C/W
(400 LF/Min Air Flow)	67°C/W	67°C/W
N Package	135°C/W	135°C/W
J-Package	110°C/W	110°C/W
(Typical) θ_{jC}		
H-Package	25°C/W	25°C/W
Storage Temperature Range	-65°C to +150°C	-65°C to +150°C
Lead Temperature (Soldering, 10 sec.)		
Metal Can or Ceramic	300°C	300°C
Plastic	260°C	260°C
ESD Tolerance (Note 5)	2000V	2000V

Electrical Characteristics (Note 3) T_A = T_J

Parameter	Conditions	LM101A/LM201A			LM301A			Units
		Min	Typ	Max	Min	Typ	Max	
Input Offset Voltage	T _A = 25°C, R _S ≤ 50 kΩ		0.7	2.0		2.0	7.5	mV
Input Offset Current	T _A = 25°C		1.5	10		3.0	50	nA
Input Bias Current	T _A = 25°C		30	75		70	250	nA
Input Resistance	T _A = 25°C	1.5	4.0		0.5	2.0		MΩ
Supply Current	T _A = 25°C	V _S = ±20V	1.8	3.0				mA
		V _S = ±15V				1.8	3.0	mA
Large Signal Voltage Gain	T _A = 25°C, V _S = ±15V V _{OUT} = ±10V, R _L ≥ 2 kΩ	50	160		25	160		V/mV
Input Offset Voltage	R _S ≤ 50 kΩ			3.0			10	mV
Average Temperature Coefficient of Input Offset Voltage	R _S ≤ 50 kΩ		3.0	15		6.0	30	μV/°C
Input Offset Current				20			70	nA
Average Temperature Coefficient of Input Offset Current	25°C ≤ T _A ≤ T _{MAX} T _{MIN} ≤ T _A ≤ 25°C		0.01	0.1		0.01	0.3	nA/°C
			0.02	0.2		0.02	0.6	nA/°C

Electrical Characteristics (Note 3) $T_A = T_J$ (Continued)

Parameter	Conditions	LM101A/LM201A			LM301A			Units
		Min	Typ	Max	Min	Typ	Max	
Input Bias Current				0.1			0.3	μ A
Supply Current	$T_A = T_{MAX}$, $V_S = \pm 20V$		1.2	2.5				mA
Large Signal Voltage Gain	$V_S = \pm 15V$, $V_{OUT} = \pm 10V$ $R_L \geq 2k$	25			15			V/mV
Output Voltage Swing	$V_S = \pm 15V$	$R_L = 10k\Omega$	± 12	± 14	± 12	± 14		V
		$R_L = 2k\Omega$	± 10	± 13	± 10	± 13		V
Input Voltage Range	$V_S = \pm 20V$	± 15						V
	$V_S = \pm 15V$		+15, -13		± 12	+15, -13		V
Common-Mode Rejection Ratio	$R_S \leq 50k\Omega$	80	96		70	90		dB
Supply Voltage Rejection Ratio	$R_S \leq 50k\Omega$	80	96		70	96		dB

Note 1: For supply voltages less than $\pm 15V$, the absolute maximum input voltage is equal to the supply voltage.

Note 2: Continuous short circuit is allowed for case temperatures to $125^\circ C$ and ambient temperatures to $75^\circ C$ for LM101A/LM201A, and $70^\circ C$ and $55^\circ C$ respectively for LM301A.

Note 3: Unless otherwise specified, these specifications apply for $C_1 = 30pF$, $\pm 5V \leq V_S \leq \pm 20V$ and $-55^\circ C \leq T_A \leq +125^\circ C$ (LM101A), $\pm 5V \leq V_S \leq \pm 20V$ and $-25^\circ C \leq T_A \leq +85^\circ C$ (LM201A), $\pm 5V \leq V_S \leq \pm 15V$ and $0^\circ C \leq T_A \leq +70^\circ C$ (LM301A).

Note 4: Refer to RETS101AX for LM101A military specifications and RETS101X for LM101 military specifications.

Note 5: Human body model, 100 pF discharged through 1.5 k Ω .

Guaranteed Performance Characteristics LM101A/LM201A

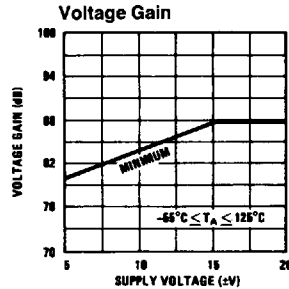
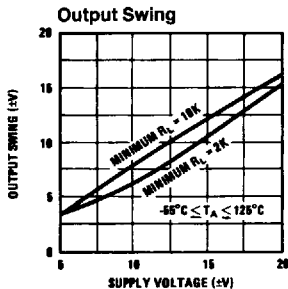
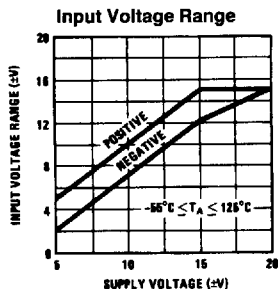

TL/H/7752-5

Guaranteed Performance Characteristics LM301A

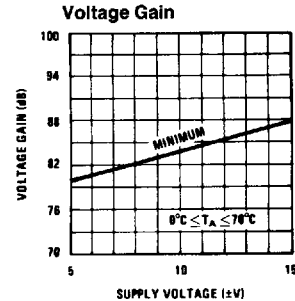
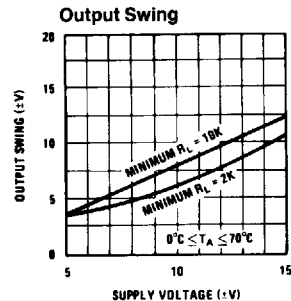
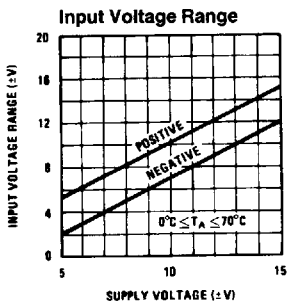

TL/H/7752-6

NATL SEMICOND (LINEAR)

LM101A/LM201A/LM301A

Typical Performance Characteristics

NATL SEMICOND (LINEAR)

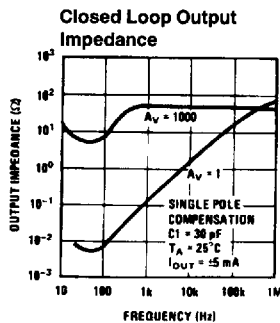
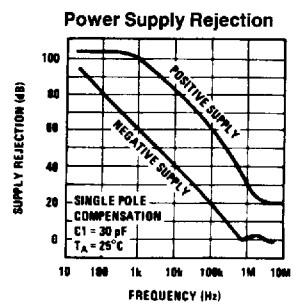
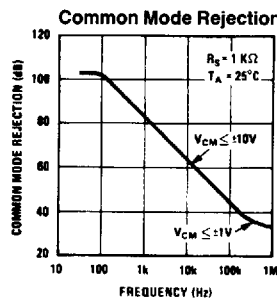
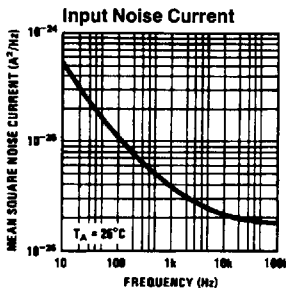
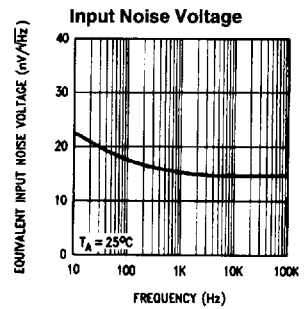
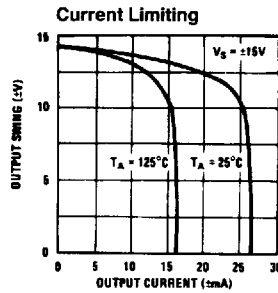
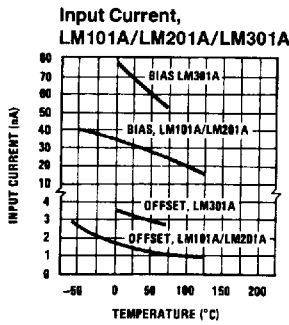
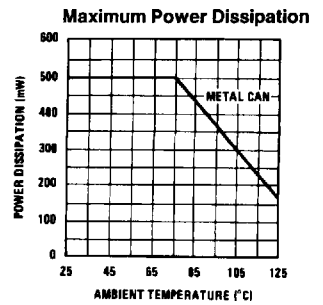
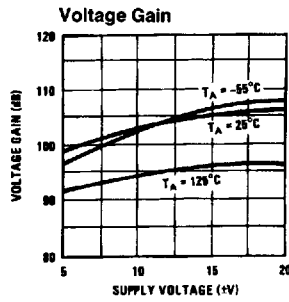
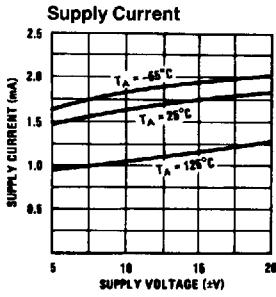

TL/H/7752-7

Typical Performance Characteristics for Various Compensation Circuits**

Single Pole Compensation

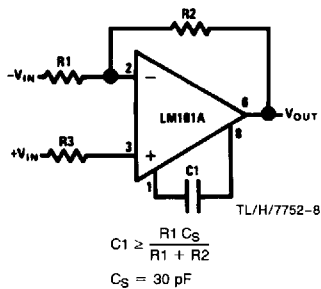

Two Pole Compensation

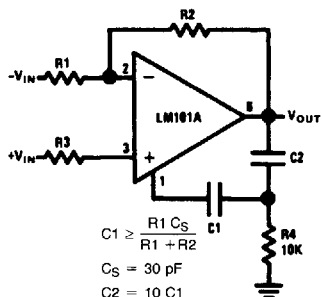

Feedforward Compensation

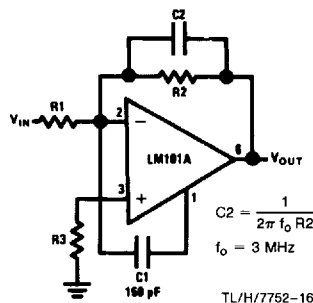

Open Loop Frequency Response

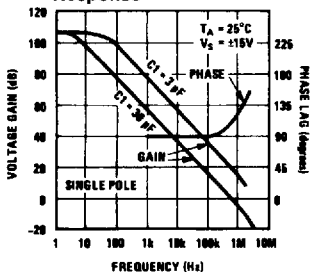

Open Loop Frequency Response

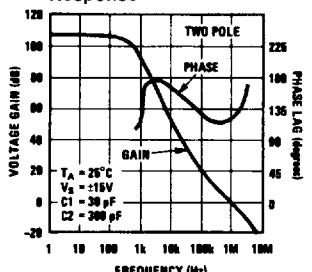

Open Loop Frequency Response

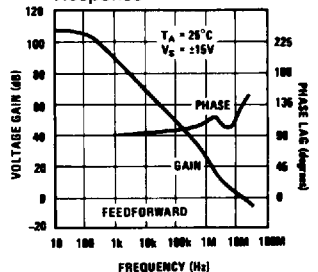

Large Signal Frequency Response

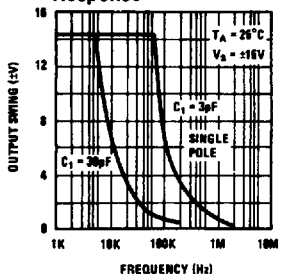

Large Signal Frequency Response

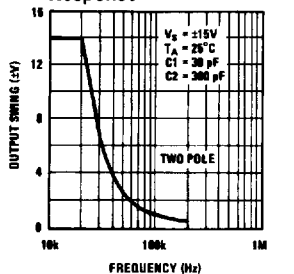

Large Signal Frequency Response

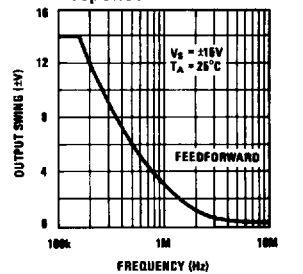

Voltage Follower Pulse Response

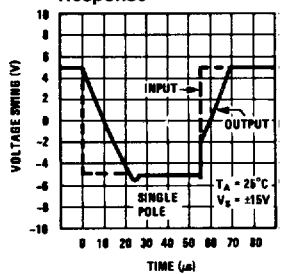

Voltage Follower Pulse Response

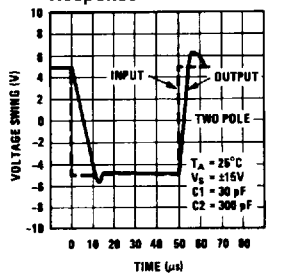

Inverter Pulse Response

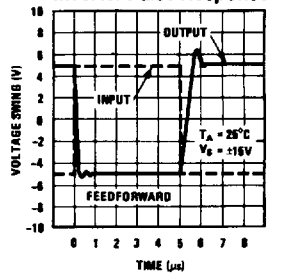

**Pin connections shown are for 8-pin packages.

Typical Applications**

NATL SEMICON (LINEAR)

Variable Capacitance Multiplier

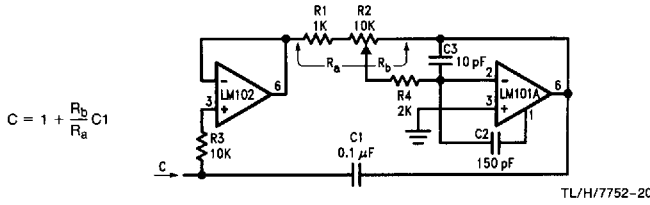

Simulated Inductor

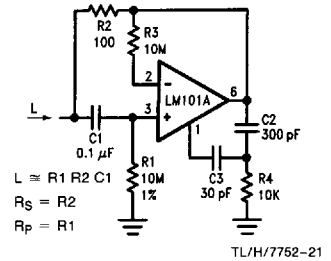

Fast Inverting Amplifier with High Input Impedance

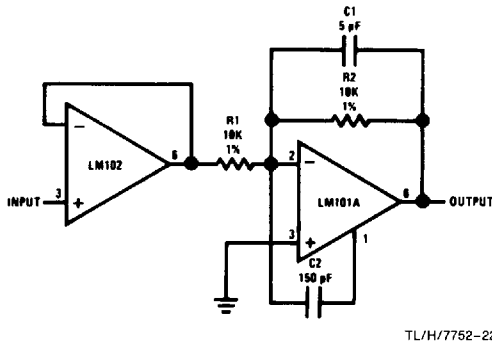

Inverting Amplifier with Balancing Circuit

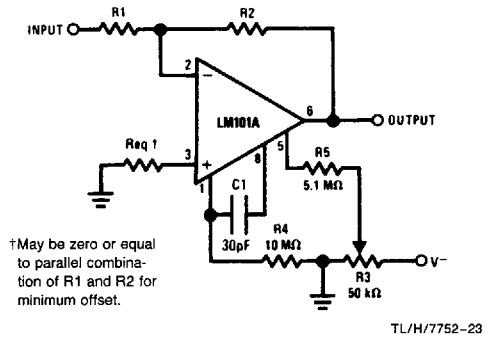

Sine Wave Oscillator

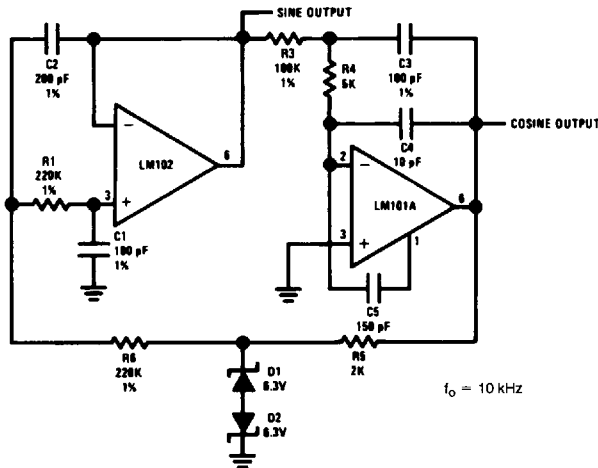

Integrator with Bias Current Compensation

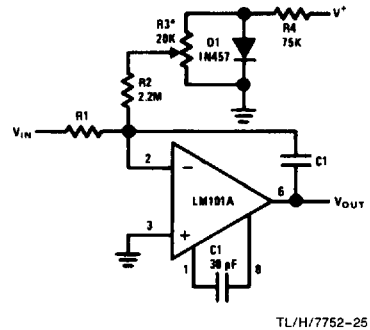

*Adjust for zero integrator drift. Current drift typically 0.1 nA/°C over -55°C to +125°C temperature range.

**Pin connections shown are for 8-pin packages.

Application Hints**

Protecting Against Gross Fault Conditions

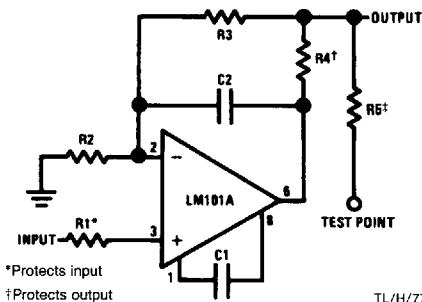

*Protects input
†Protects output

‡Protects output—not needed when R4 is used.

TL/H/7752-26

Compensating for Stray Input Capacitances or Large Feedback Resistor

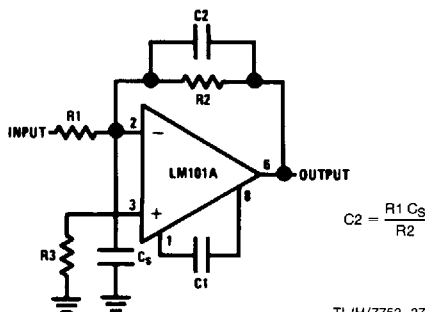

$$C_2 = \frac{R_1 C_s}{R_2}$$

TL/H/7752-27

Isolating Large Capacitive Loads

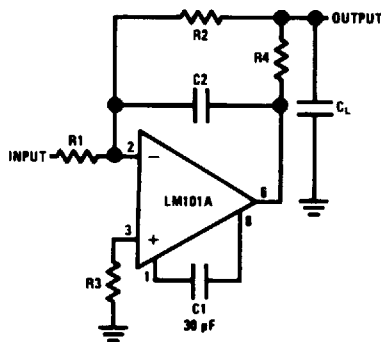

TL/H/7752-28

Although the LM101A is designed for trouble free operation, experience has indicated that it is wise to observe certain precautions given below to protect the devices from abnormal operating conditions. It might be pointed out that the advice given here is applicable to practically any IC op amp, although the exact reason why may differ with different devices.

When driving either input from a low-impedance source, a limiting resistor should be placed in series with the input lead to limit the peak instantaneous output current of the source to something less than 100 mA. This is especially important when the inputs go outside a piece of equipment where they could accidentally be connected to high voltage sources. Large capacitors on the input (greater than 0.1 μ F) should be treated as a low source impedance and isolated with a resistor. Low impedance sources do not cause a problem unless their output voltage exceeds the supply voltage. However, the supplies go to zero when they are turned off, so the isolation is usually needed.

The output circuitry is protected against damage from shorts to ground. However, when the amplifier output is connected to a test point, it should be isolated by a limiting resistor, as test points frequently get shorted to bad places. Further, when the amplifier drives a load external to the equipment, it is also advisable to use some sort of limiting resistance to preclude mishaps.

Precautions should be taken to insure that the power supplies for the integrated circuit never become reversed—even under transient conditions. With reverse voltages greater than 1V, the IC will conduct excessive current, fusing internal aluminum interconnects. If there is a possibility of this happening, clamp diodes with a high peak current rating should be installed on the supply lines. Reversal of the voltage between V^+ and V^- will always cause a problem, although reversals with respect to ground may also give difficulties in many circuits.

The minimum values given for the frequency compensation capacitor are stable only for source resistances less than 10 k Ω , stray capacitances on the summing junction less than 5 pF and capacitive loads smaller than 100 pF. If any of these conditions are not met, it becomes necessary to overcompensate the amplifier with a larger compensation capacitor. Alternately, lead capacitors can be used in the feedback network to negate the effect of stray capacitance and large feedback resistors or an RC network can be added to isolate capacitive loads.

Although the LM101A is relatively unaffected by supply bypassing, this cannot be ignored altogether. Generally it is necessary to bypass the supplies to ground at least once on every circuit card, and more bypass points may be required if more than five amplifiers are used. When feed-forward compensation is employed, however, it is advisable to bypass the supply leads of each amplifier with low inductance capacitors because of the higher frequencies involved.

**Pin connections shown are for 8-pin packages.

Typical Applications** (Continued)

NATL SEMICON (LINEAR)

Standard Compensation and Offset Balancing Circuit

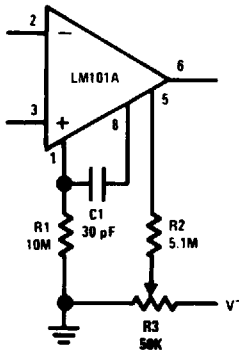

TL/H/7752-29

Fast Summing Amplifier

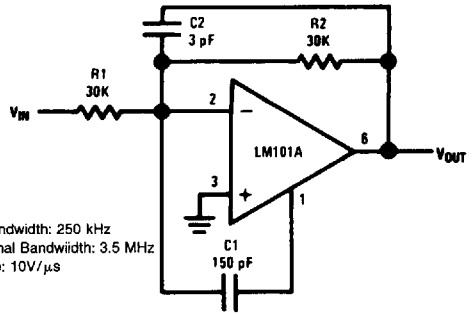

Power Bandwidth: 250 kHz
Small Signal Bandwidth: 3.5 MHz
Slew Rate: 10V/μs

TL/H/7752-30

Fast Voltage Follower

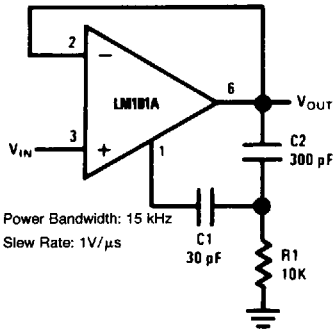

Power Bandwidth: 15 kHz
Slew Rate: 1V/μs

TL/H/7752-31

Bilateral Current Source

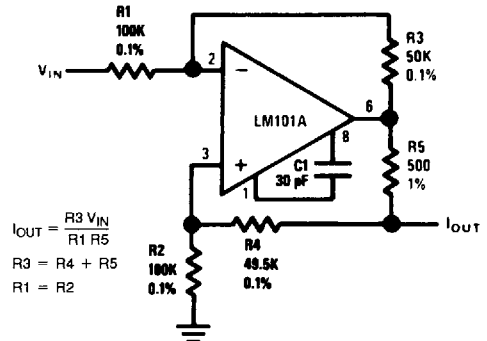

$$I_{OUT} = \frac{R3 V_{IN}}{R1 R5}$$

$$R3 = R4 + R5$$

$$R1 = R2$$

TL/H/7752-32

Fast AC/DC Converter*

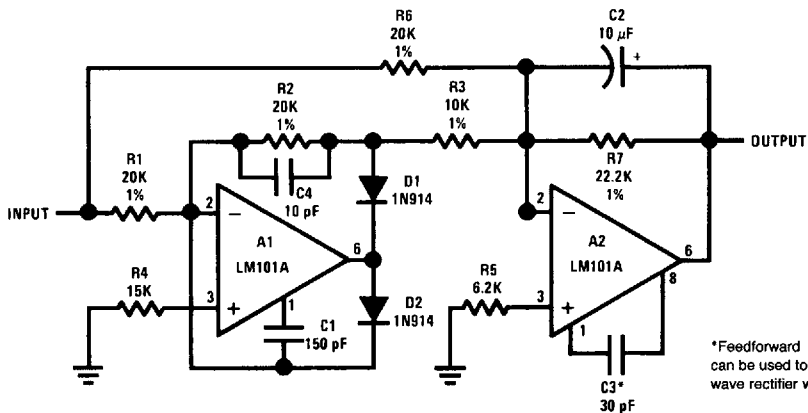

*Feedforward compensation can be used to make a fast full wave rectifier without a filter.

TL/H/7752-33

**Pin connections shown are for 8-pin packages.

Typical Applications** (Continued)

NATL SEMICOND (LINEAR)

Instrumentation Amplifier

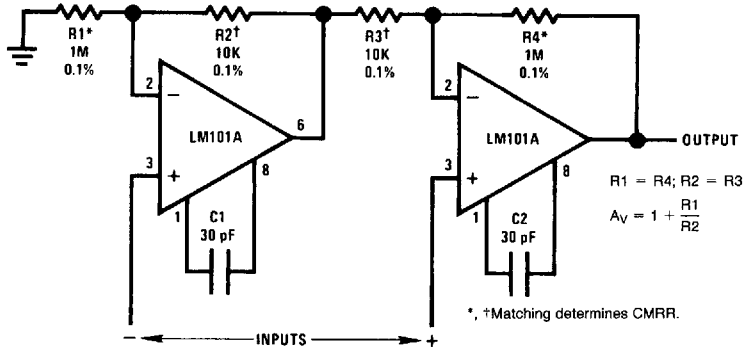

TL/H/7752-34

Integrator with Bias Current Compensation

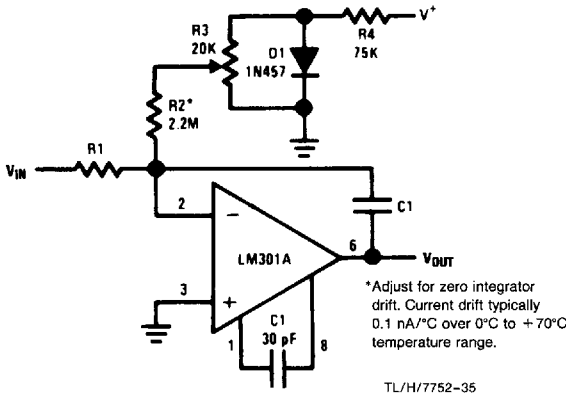

TL/H/7752-35

Voltage Comparator for Driving RTL Logic or High Current Driver

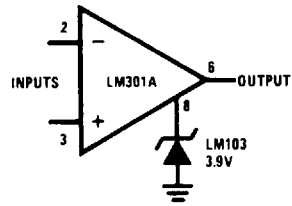

TL/H/7752-37

Low Frequency Square Wave Generator

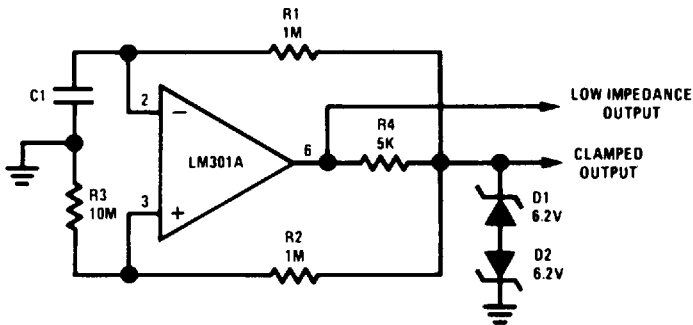

TL/H/7752-36

**Pin connections shown are for 8-pin packages.

LM101A/LM201A/LM301A

Typical Applications** (Continued)

NATL SEMICON (LINEAR)

Low Drift Sample and Hold

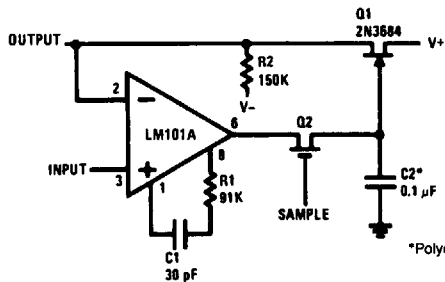

*Polycarbonate-dielectric capacitor

Voltage Comparator for Driving DTL or TTL Integrated Circuits

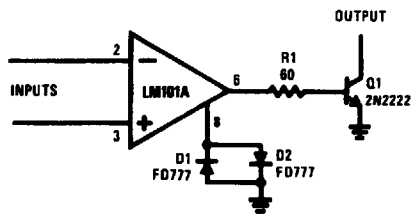

TL/H/7752-39

Schematic**

TL/H/7752-38

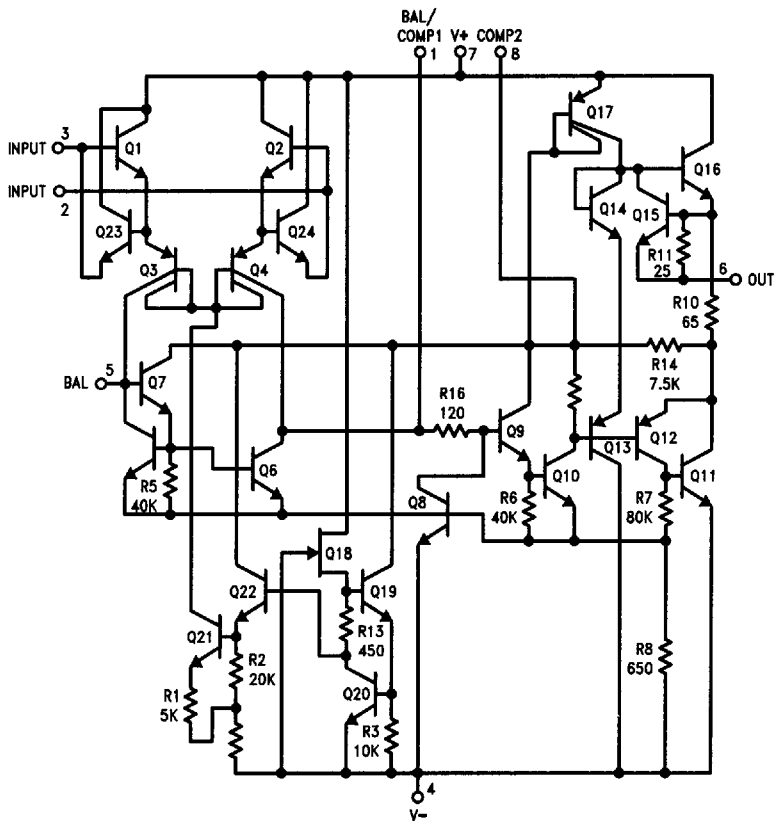

TL/H/7752-1

**Pin connections shown are for 8-pin packages.