



# HARRIS

## Operational Amplifiers/Buffers

LM108A/LM308A

### LM108A/LM308A Operational Amplifiers

#### General Description

The LM108A/308A series are precision operational amplifiers having specifications about a factor of ten better than FET amplifiers over their operating temperature range. In addition to low input currents, these devices have extremely low offset voltage, making it possible to eliminate offset adjustments, in most cases, and obtain performance approaching chopper stabilized amplifiers.

The devices operate with supply voltages from  $\pm 3V$  to  $\pm 18V$  and have sufficient supply rejection to use unregulated supplies. They are fabricated using the Harris dielectric isolation process which coupled with our unique design makes external compensation unnecessary. Outstanding characteristics include:

- Offset voltage guaranteed less than 0.25mV

- Maximum input bias current of 4.0 nA over temperature
- Offset current less than 4.0 nA over temperature
- Supply current of only 1 mA
- Guaranteed  $.6 \mu V/^\circ C$  drift
- External compensation components not required

The low current error of the LM108A series makes possible many designs that are not practical with conventional amplifiers. In fact, it operated from  $10M\Omega$  source resistances, introducing less error than devices like the 709 with  $10 k\Omega$  sources. Integrators with drifts less than  $500 \mu V/sec$  and analog time delays in excess of one hour can be made using capacitors no larger than  $1 \mu F$ .

The LM308A devices have slightly relaxed specifications and performance guaranteed over a  $0^\circ C$  to  $70^\circ C$  temperature range.

#### Typical Characteristics

Standard Differential Amplifier

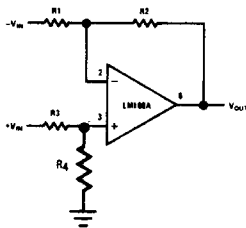

Sample and Hold

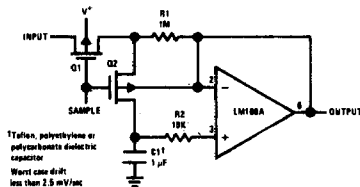

High Speed Amplifier with Low Drift and Low Input Current

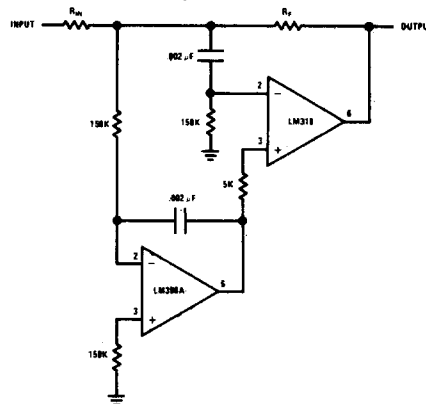

## LM108A

### Absolute Maximum Ratings

Supply Voltage	±20V
Power Dissipation (Note 1)	500 mW
Differential Input Current (Note 2)	±10 mA
Input Voltage (Note 3)	±15V
Output Short-Circuit Duration	Indefinite
Operating Temperature Range LM108A	-55°C to 125°C
Storage Temperature Range	-65°C to 150°C
Lead Temperature (Soldering, 10 sec)	300°C

### Electrical Characteristics (Note 4)

PARAMETER	CONDITIONS	MIN	TYP	MAX	UNITS
Input Offset Voltage	$V_S = \pm 15V, T_A = 25^\circ C$		.01	.025	mV
Input Offset Current			0.05	2.0	nA
Input Bias Current			0.8	2.0	nA
Input Resistance		10	30		MΩ
Supply Current			1.0	1.7	mA
Large Signal Voltage Gain	$V_{OUT} = \pm 10V, R_L \geq 10 k\Omega$	120	140		dB
Input Offset Voltage	$V_S = \pm 15V$			.06	mV
Average Temperature Coefficient of Input Offset Voltage	$-55^\circ C \leq T_A \leq +125^\circ C$		.4	.6	$\mu V/^\circ C$
Input Offset Current				4.0	nA
Average Temperature Coefficient of Input Offset Current				.04	nA/°C
Input Bias Current				4.0	nA
Supply Current			1.0	1.7	mA
Large Signal Voltage Gain	$V_{OUT} = \pm 10V$ $R_L \geq 10 k\Omega$	120			dB
Output Voltage Swing	$R_L = 10 k\Omega$	±10	±12		V
Input Voltage Range		±12			V
Common Mode Rejection Ratio		106	120		dB
Supply Voltage Rejection Ratio		100	130		dB

**Note 1:** The maximum junction temperature of the LM108A is 150°C. For operating at elevated temperatures, devices in the TO-5 package must be derated based on a thermal resistance of 150°C/W, junction to ambient, or 45°C/W, junction to case. The thermal resistance of the dual-in-line package is 100°C/W, junction to ambient.

**Note 2:** If a differential input voltage in excess of the operating supply is applied between the inputs, excessive current will flow unless some limiting resistance is used.

**Note 3:** For supply voltages less than ±15V, the absolute maximum input voltage is equal to the supply voltage.

**Note 4:** The device operating supply voltage range is  $+3V \leq V_S \leq +18V$ .

## LM308A

## Absolute Maximum Ratings

Supply Voltage	±18V
Power Dissipation (Note 1)	500 mW
Differential Input Current (Note 2)	±10 mA
Input Voltage (Note 3)	±15V
Output Short-Circuit Duration	Indefinite
Operating Temperature Range	0°C to 70°C
Storage Temperature Range	-65°C to 150°C
Lead Temperature (Soldering, 10 sec)	300°C

## Electrical Characteristics (Note 4)

PARAMETER	CONDITIONS	MIN	TYP	MAX	UNITS	
Input Offset Voltage	$V_S = \pm 15V, T_A = 25^\circ C$		.01	.025	mV	
Input Offset Current			0.2	2.0	nA	
Input Bias Current				1.5	2.0	nA
Input Resistance				30		MΩ
Supply Current				1.0	1.7	mA
Large Signal Voltage Gain		$V_{OUT} = \pm 10V, R_L \geq 10 \text{ k}\Omega$	120	140		dB
Input Offset Voltage LM308A	$V_S = \pm 15V$ $0^\circ C \leq T_A \leq +70^\circ C$			.06	mV	
Average Temperature Coefficient of Input Offset Voltage LM308A			.4	.6	μV/°C	
Supply Current				1.0	1.7	mA
Input Offset Current					4.0	nA
Average Temperature Coefficient of Input Offset Current					0.04	nA/°C
Input Bias Current					4	nA
Large Signal Voltage Gain		$V_{OUT} = \pm 10V$ $R_L \geq 10 \text{ k}\Omega$	120			dB
Output Voltage Swing		$R_L = 10 \text{ k}\Omega$	±10	±12		V
Input Voltage Range			±12			dB
Common-Mode Rejection Ratio			106	120		dB
Supply Voltage Rejection Ratio		100	130		dB	

**Note 1:** The maximum junction temperature of the LM308A, LM308-1, and LM308-2 is 85°C. For operating at elevated temperatures, devices in the TO-5 package must be derated based on a thermal resistance of 150°C/W, junction to ambient, or 45°C/W, junction to case. The thermal resistance of the dual-in-line package is 100°C/W, junction to ambient.

**Note 2:** If a differential input voltage in excess of the operating supply is applied between the inputs, excessive current will flow unless some limiting resistance is used.

**Note 3:** For supply voltages less than ±15V, the absolute maximum input voltage is equal to the supply voltage.

**Note 4:** The device operating supply voltage range is  $+3V \leq V_S \leq \pm 18V$ .

## Application Hints

A very low drift amplifier poses some uncommon application and testing problems. Many sources of error can cause the apparent circuit drift to be much higher than would be predicted.

Thermocouple effects caused by temperature gradient across dissimilar metals are perhaps the worst offenders. Only a few degrees gradient can cause hundreds of microvolts of error. The two places this shows up, generally, are the package-to printed circuit board interface and temperature gradients across resistors. Keeping package leads short and the two input leads close together help greatly.

Resistor choice as well as physical placement is important for minimizing thermocouple effects. Carbon, oxide film and some metal film resistors can cause large thermocouple errors. Wirewound resistors of evenohm or manganin are best since they only generate about  $2 \mu\text{V}/^\circ\text{C}$  referenced to copper. Of course, keeping the resistor ends at the same temperature is important. Generally, shielding a low drift stage electrically and thermally will yield good results.

Resistors can cause other errors besides gradient generated voltages. If the gain setting resistors do not track with temperature a gain error will result. For example a gain of 1000 amplifier with a con-

stant 10 mV input will have a 10V output. If the resistors mistrack by 0.5% over the operating temperature range, the error at the output is 50 mV. Referred to input, this is a  $50 \mu\text{V}$  error. All of the gain fixing resistor should be the same material.

Offset balancing the LM308A is not a problem since there is an easy offset adjustment incorporated into the circuit. This adjustment can be accomplished by simply using the circuit given below.

In addition to the suggested offset nulling method, this adjustment can also be done at the input by employing one of the three commonly used circuits shown.

Testing low drift amplifiers is also difficult. Standard drift testing technique such as heating the device in an oven and having the leads available through a connector, thermoprobe, or the soldering iron method — do not work. Thermal gradients cause much greater errors than the amplifier drift. Coupling microvolt signal through connectors is especially bad since the temperature difference across the connector can be  $50^\circ\text{C}$  or more. The device under test along with the gain setting resistor should be isothermal. The following circuit will yield good results if well constructed.

Suggested Connections for Offset Nulling

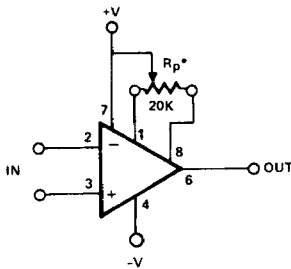

\* Although  $R_p$  is shown equal to 20k, other values such as 50k, 100k, and 1M may be used. Range of adjustment is approximately  $\pm 2.5\text{mV}$ .  $\text{VOS}$ TC of the amplifier is not compromised.

For Inverting Amplifiers

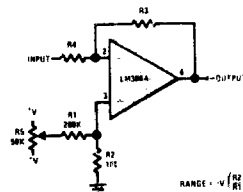

For Non-Inverting Amplifiers

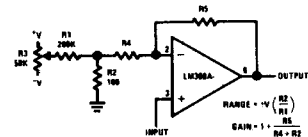

Offset Adjustment for Differential Amplifiers

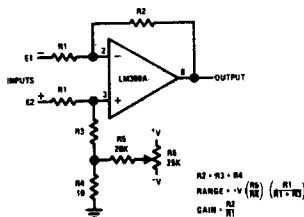

Drift Measurement Circuit

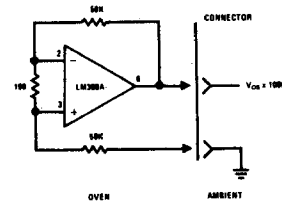

Schematic Diagram \*

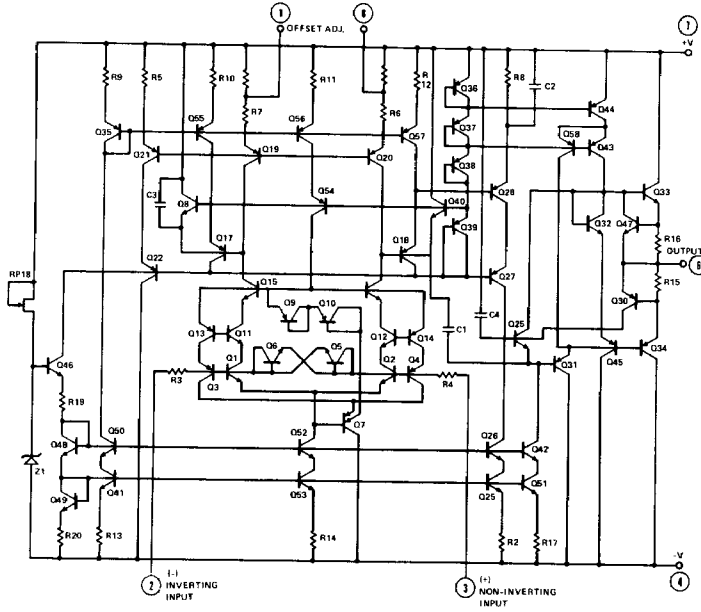

\* Pin connections shown on schematic diagram refer to T0-5 and Dual-In-Line Package

Connection Diagrams Section 11 for Packaging

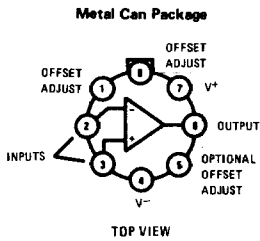

Order Number LM108AH,  
LM308AH

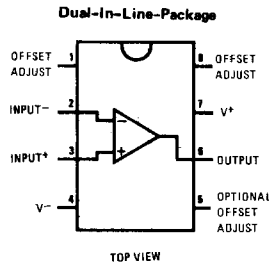

Order Number LM108AJ-8  
LM308AJ-8

Order Number LM308AN