



FORWARD INTERNATIONAL ELECTRONICS LTD.

**SEMICONDUCTOR
TECHNICAL DATA**

**BR2505
THRU
BR2510**

**TECHNICAL SPECIFICATIONS OF SINGLE-PHASE SILICON BRIDGE RECTIFIER
VOLTAGE RANGE - 50 to 1000 Volts
CURRENT - 25 Amperes**

FEATURES

- * Plastic case with heatsink for Maximum Heat Dissipation
- * Surge overload ratings-400 Amperes
- * Low forward voltage drop

MECHANICAL DATA

- * Case: Molded plastic with heatsink
- * Epoxy: UL 94V-0 rate flame retardant
- * Terminals: Plated .25"(6.35mm) Faston lugs, Solderable per MIL-STD-202E, Method 208 guaranteed
- * Polarity: As marked
- * Mounting position: Any
- * Weight: 30 grams

MAXIMUM RATINGS AND ELECTRICAL CHARACTERISTICS

Ratings at 25 °C ambient temperature unless otherwise specified.
Single phase, half wave, 60 Hz, resistive or inductive load.
For capacitive load, derate current by 20%.



BR-25

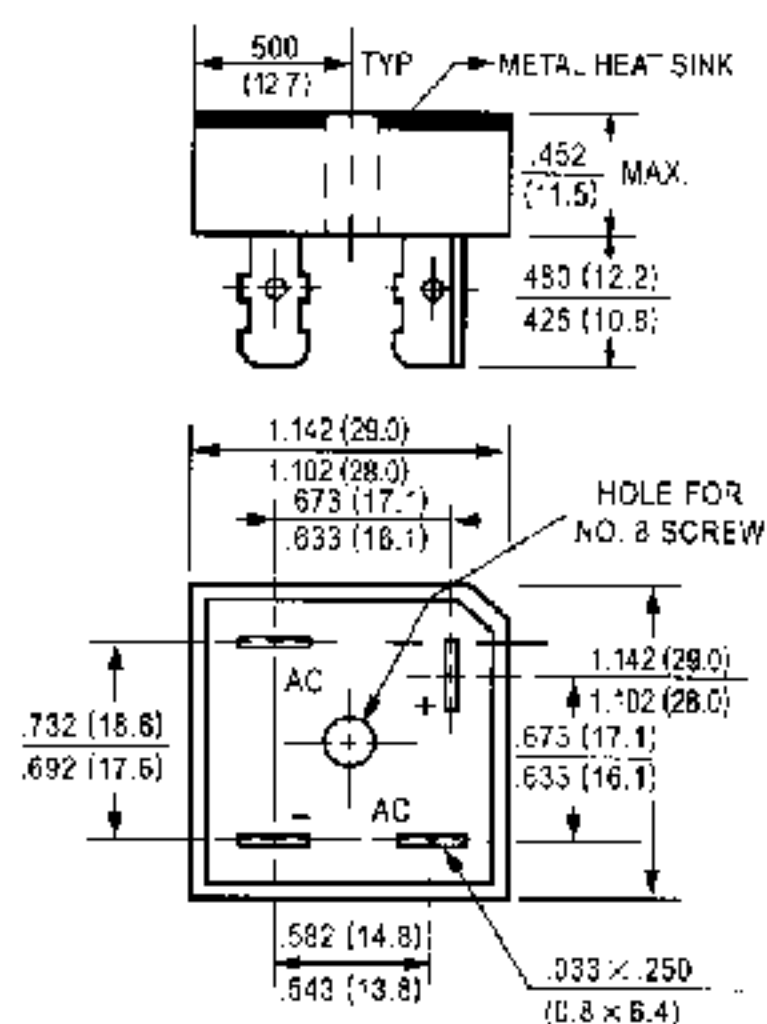

Dimensions in inches and (millimeters)

	SYMBOL	BR2505	BR251	BR252	BR254	BR256	BR258	BR2510	UNITS
Maximum Recurrent Peak Reverse Voltage	V_{RRM}	50	100	200	400	600	800	1000	Volts
Maximum RMS Bridge Input Voltage	V_{RMS}	35	70	140	280	420	560	700	Volts
Maximum DC Blocking Voltage	V_{RC}	50	100	200	400	600	800	1000	Volts
Maximum Average Forward Rectified Output Current at $T_c = 55^\circ C$	I_c	25							Amps
Peak Forward Surge Current 8.3 ms single half sine-wave superimposed on rated load (JEDEC Method)	I_{FSM}	400							Amps
Maximum Forward Voltage Drop per element at 12.5A DC	V_f	1.1							Volts
Maximum DC Reverse Current at Rated DC Blocking Voltage per element	I_R	@ $T_A = 25^\circ C$							uAmps
		@ $T_A = 100^\circ C$							
I^2t Rating for Fusing ($t < 8.3ms$)	I^2t	374							A ² Sec
Typical Junction Capacitance (Note 1)	C_j	300							pF
Typical Thermal Resistance (Note 2)	$R_{\theta JC}$	2.5							°C/W
Operating and Storage Temperature Range	T_j, T_{stg}	-55 to +150							°C

NOTES : 1. Measured at 1 MHz and applied reverse voltage of 4.0 volts
2. Thermal Resistance from Junction to Case per leg.

RATING AND CHARACTERISTIC CURVES (BR2505 THRU BR2510)

FIG. 1 - MAXIMUM NON-REPETITIVE FORWARD SURGE CURRENT

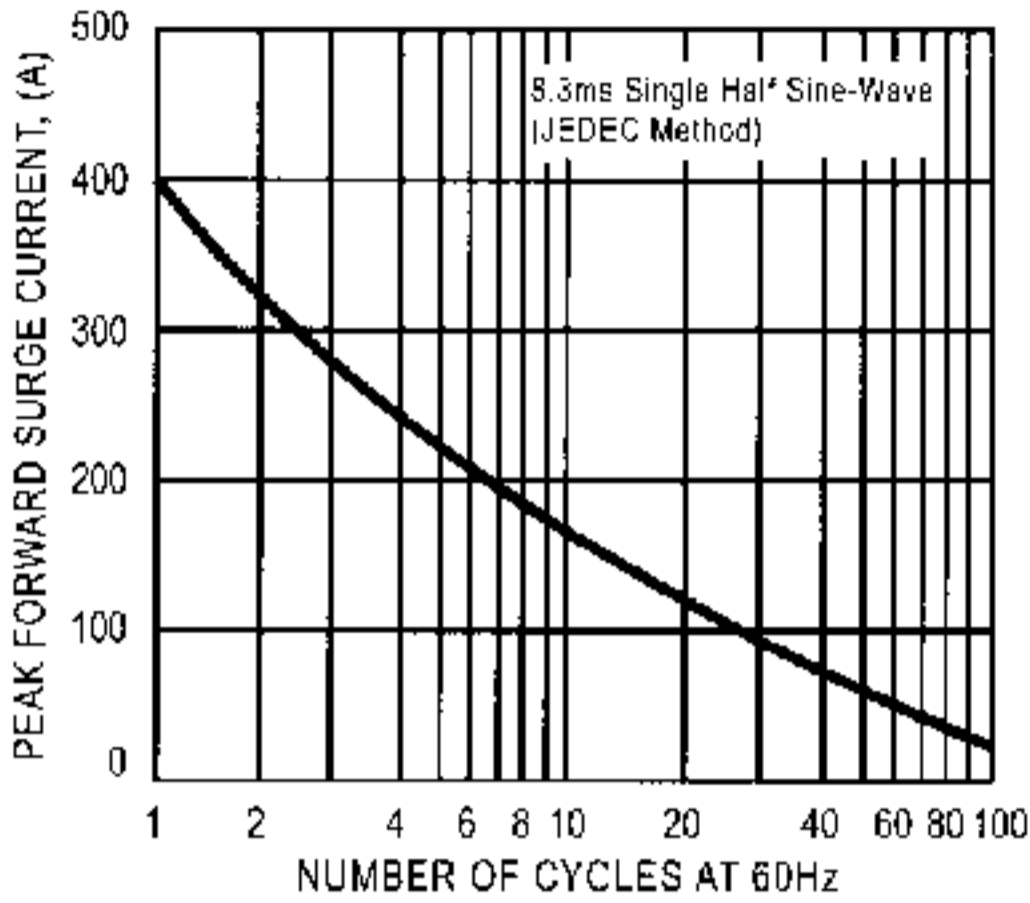

FIG. 2 - TYPICAL FORWARD CURRENT DERATING CURVE

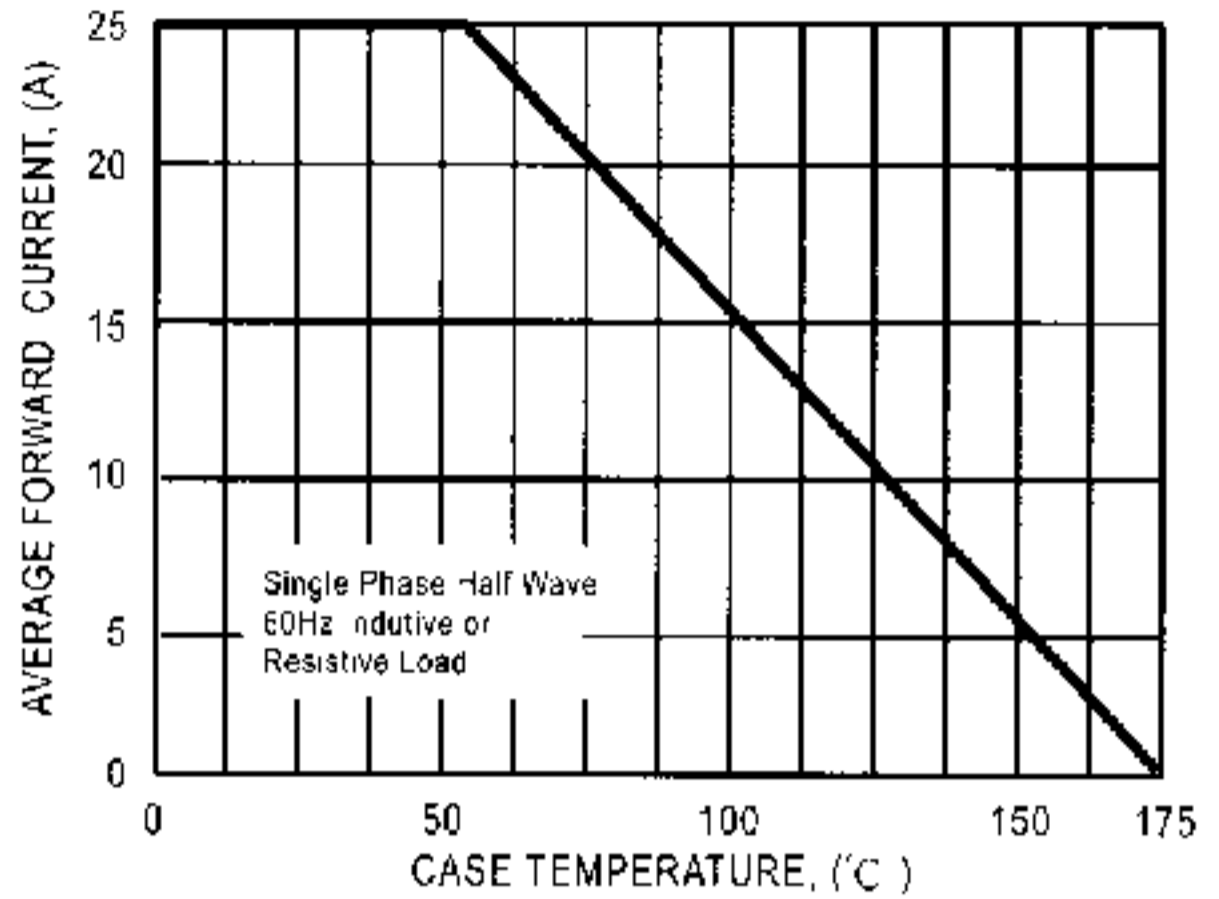

FIG. 3 - TYPICAL INSTANTANEOUS FORWARD CHARACTERISTICS

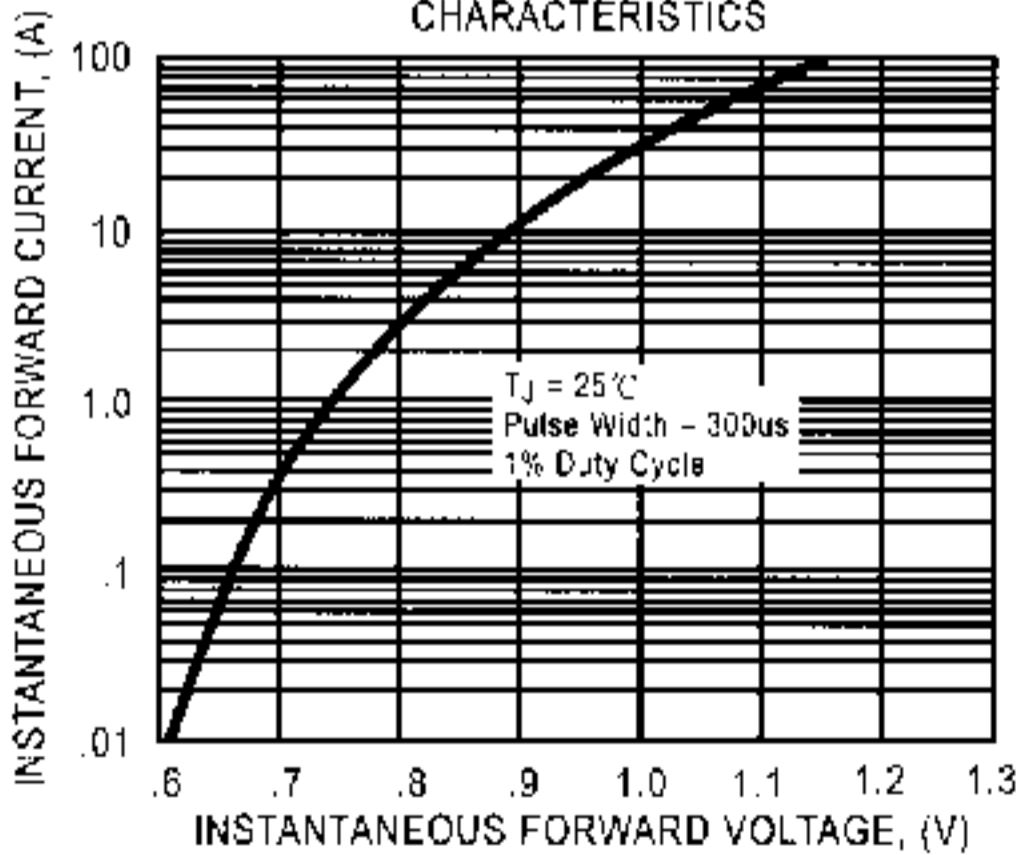

FIG. 4 - TYPICAL REVERSE CHARACTERISTICS

