

REVISIONS			
LTR	DESCRIPTION	DATE (YR-MO-DA)	APPROVED
F	Figure 1; changed case outline M to be available in either a single or dual cavity package. Added vendor CAGE code 0EU86 for device types 05 through 10. -sld	99-04-22	K. A. Cottongim
G	Added device types 11 through 16.	99-08-18	Raymond Monnin
H	Add note to paragraph 1.2.2 and table I, conditions. Add thermal resistance, junction-to-case (θ_{JC}) for all case outlines. Add case outline 9.	00-04-06	Raymond Monnin
J	Table I, I_{CC} change maximum limits and I_{SB} change maximum limits. Figure 1, case outline M, correct diagram adding "c" dimension, lead thickness and change dimension A2 maximum from 0.020" to 0.025".	00-06-19	Raymond Monnin
K	Figure 1, case outline 9, minimum dimension for D2/E2, change 0.990 inches to 0.980 inches and 25.15 mm to 24.89 mm.	01-5-16	Raymond Monnin
L	Table I; Operating supply current (I_{CC}) changed the maximum limit for device types 9 and 15 at $f = 50$ MHz from 700 mA to 725 mA and for device types 10 and 16 at $f = 58.8$ MHz from 700 mA to 750 mA. -sld	01-12-21	Raymond Monnin
M	Added device types 17 through 20. -sld	02-11-18	Raymond Monnin
N	Added case outline A. -sld	03-02-24	Raymond Monnin
P	Added case outline B. Added note to paragraph 1.2.4. -sld	03-12-19	Raymond Monnin
R	Table I; Changed the I_{OL} from 8 mA to 6 mA for device types 07-10 and 13 -20 for the V_{OL} test. Editorial changes throughout. -sld	04-05-03	Raymond Monnin

REV																							
SHEET																							
REV	R	R	R	R	R	R	R	R	R	R	R	R	R	R	R	R	R	R					
SHEET	15	16	17	18	19	20	21	22	23	24	25	26	27	28	29	30	31						
REV STATUS OF SHEETS	REV			R	R	R	R	R	R	R	R	R	R	R	R	R	R	R	R	R	R		
	SHEET			1	2	3	4	5	6	7	8	9	10	11	12	13	14						
PMIC N/A	PREPARED BY Gary Zahn				DEFENSE SUPPLY CENTER COLUMBUS COLUMBUS, OHIO 43216 http://www.dsccl.dla.mil MICROCIRCUIT, HYBRID, MEMORY, DIGITAL, 512K x 32-BIT, STATIC RANDOM ACCESS MEMORY, CMOS																		
STANDARD MICROCIRCUIT DRAWING THIS DRAWING IS AVAILABLE FOR USE BY ALL DEPARTMENTS AND AGENCIES OF THE DEPARTMENT OF DEFENSE AMSC N/A	CHECKED BY Michael C. Jones																						
	APPROVED BY Kendall A. Cottongim																						
	DRAWING APPROVAL DATE 95-11-13																						
	REVISION LEVEL R				SIZE A	CAGE CODE 67268	5962-94611																
						SHEET			1 OF 31														

1. SCOPE

1.1 Scope. This drawing documents five product assurance classes as defined in paragraph 1.2.3 and MIL-PRF-38534. A choice of case outlines and lead finishes which are available and are reflected in the Part or Identifying Number (PIN). When available, a choice of radiation hardness assurance levels are reflected in the PIN.

1.2 PIN. The PIN shall be as shown in the following example:

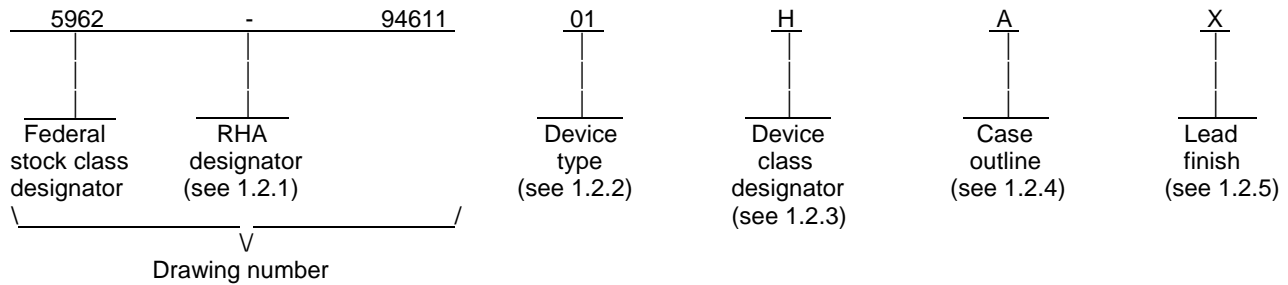

1.2.1 Radiation hardness assurance (RHA) designator. RHA marked devices shall meet the MIL-PRF-38534 specified RHA levels and shall be marked with the appropriate RHA designator. A dash (-) indicates a non-RHA device.

1.2.2 Device type(s). The device type(s) shall identify the circuit function as follows:

<u>Device type</u> 1/ 2/	<u>Generic number</u>	<u>Circuit function</u>	<u>Access time</u>
01	S512K32-120	512K X 32-BIT SRAM	120 ns
02	S512K32-100	512K X 32-BIT SRAM	100 ns
03	S512K32-85	512K X 32-BIT SRAM	85 ns
04	S512K32-70	512K X 32-BIT SRAM	70 ns
05	S512K32-55	512K X 32-BIT SRAM	55 ns
06	S512K32-45	512K X 32-BIT SRAM	45 ns
07	S512K32-35	512K X 32-BIT SRAM	35 ns
08	S512K32-25	512K X 32-BIT SRAM	25 ns
09	S512K32-20	512K X 32-BIT SRAM	20 ns
10	S512K32-17	512K X 32-BIT SRAM	17 ns
11	S512K32-55	512K X 32-BIT SRAM	55 ns
12	S512K32-45	512K X 32-BIT SRAM	45 ns
13	S512K32-35	512K X 32-BIT SRAM	35 ns
14	S512K32-25	512K X 32-BIT SRAM	25 ns
15	S512K32-20	512K X 32-BIT SRAM	20 ns
16	S512K32-17	512K X 32-BIT SRAM	17 ns
17	S512K32-15	512K X 32-BIT SRAM	15 ns
18	S512K32-12	512K X 32-BIT SRAM	12 ns
19	S512K32-15	512K X 32-BIT SRAM	15 ns
20	S512K32-12	512K X 32-BIT SRAM	12 ns

1/ Due to the nature of the 4 transistor design of the die used in these device types, topologically pure testing is important, particularly for high reliability applications. The device manufacturer should be consulted concerning their testing methods and algorithms

2/ Device types 11 through 18 are not tested to data retention supply voltage (V_{DR}) and data retention current (I_{CCDR1}). See table I.

STANDARD MICROCIRCUIT DRAWING DEFENSE SUPPLY CENTER COLUMBUS COLUMBUS, OHIO 43216-5000	SIZE A		5962-94611
		REVISION LEVEL R	SHEET 2

1.2.3 Device class designator. This device class designator shall be a single letter identifying the product assurance level. All levels are defined by the requirements of MIL-PRF-38534 and require QML Certification as well as qualification (Class H, K, and E) or QML Listing (Class G and D). The product assurance levels are as follows:

<u>Device class</u>	<u>Device performance documentation</u>
K	Highest reliability class available. This level is intended for use in space applications.
H	Standard military quality class level. This level is intended for use in applications where non-space high reliability devices are required.
G	Reduced testing version of the standard military quality class. This level uses the Class H screening and In-Process Inspections with a possible limited temperature range, manufacturer specified incoming flow, and the manufacturer guarantees (but may not test) periodic and conformance inspections (Group A, B, C, and D).
E	Designates devices which are based upon one of the other classes (K, H, or G) with exception(s) taken to the requirements of that class. These exception(s) must be specified in the device acquisition document; therefore the acquisition document should be reviewed to ensure that the exception(s) taken will not adversely affect system performance.
D	Manufacturer specified quality class. Quality level is defined by the manufacturers internal, QML certified flow. This product may have a limited temperature range.

1.2.4 Case outline(s). The case outline(s) shall be as designated in MIL-STD-1835 and as follows:

<u>Outline letter</u>	<u>Descriptive designator</u>	<u>Terminals</u>	<u>Package style</u>
A	See figure 1	68	Co-fired ceramic, quad flatpack, single cavity
B	See figure 1	68	Ceramic, quad flatpack, single cavity
M ^{3/}	See figure 1	68	Co-fired ceramic, single/dual cavity, quad flatpack
T	See figure 1	66	Hex-in-line, single cavity, with standoffs
U	See figure 1	66	Hex-in-line, single cavity, with standoffs
X	See figure 1	66	Hex-in-line, single cavity, with standoffs
Y	See figure 1	68	Ceramic, quad flatpack, single cavity
9 ^{3/}	See figure 1	68	Ceramic, quad flatpack, single cavity

1.2.5 Lead finish. The lead finish shall be as specified in MIL-PRF-38534.

^{3/} Due to the short leads of case outlines M (single cavity) and case outline 9, caution should be taken if the system application is to be used where extreme thermal transitions can occur. Case outline A can be used if longer leads are necessary.

STANDARD MICROCIRCUIT DRAWING DEFENSE SUPPLY CENTER COLUMBUS COLUMBUS, OHIO 43216-5000	SIZE A		5962-94611
		REVISION LEVEL R	SHEET 3

1.3 Absolute maximum ratings. 4/

Supply voltage range (V_{CC}).....	-0.5 V dc to +7.0 V dc
Signal voltage range (V_g).....	-0.5 V dc to $V_{CC} + 0.5$ V dc
Power dissipation (P_D):	
Device types 01-04 and 17-20.....	2.2 W
Device types 05, 06, 11, and 12.....	3.2 W
Device types 07, 08, 13, and 14.....	3.6 W
Device types 09, 10, 15, and 16.....	4.4 W
Thermal resistance, junction-to-case (θ_{JC}):	
Case outline A and M.....	9.27°C/W
Case outlines T, U, and X.....	4.160°C/W
Case outline Y.....	5.251°C/W
Case outlines B and 9.....	1.495°C/W
Storage temperature range	-65°C to +150°C
Lead temperature (soldering, 10 seconds).....	+300°C
Junction temperature (T_J).....	+150°C

1.4 Recommended operating conditions.

Supply voltage range (V_{CC}).....	+4.5 V dc to +5.5 V dc
Input low voltage range (V_{IL}).....	-0.3 V dc to +0.8 V dc
Input high voltage range (V_{IH}).....	+2.2 V dc to $V_{CC} + 0.3$ V dc
Output low voltage, maximum (V_{OL})	+0.4 V dc
Output high voltage, minimum (V_{OH})	+2.4 V dc
Ambient operating temperature range (T_A).....	-55°C to +125°C

2. APPLICABLE DOCUMENTS

2.1 Government specification, standards, and handbooks. The following specification, standards, and handbooks form a part of this drawing to the extent specified herein. Unless otherwise specified, the issues of these documents are those cited in the solicitation or contract.

DEPARTMENT OF DEFENSE SPECIFICATION

MIL-PRF-38534 - Hybrid Microcircuits, General Specification for.

DEPARTMENT OF DEFENSE STANDARDS

MIL-STD-883 - Test Method Standard Microcircuits.
MIL-STD-1835 - Interface Standard for Electronic Component Case Outlines.

DEPARTMENT OF DEFENSE HANDBOOKS

MIL-HDBK-103 - List of Standard Microcircuit Drawings.
MIL-HDBK-780 - Standard Microcircuit Drawings.

(Copies of these documents are available online at <http://assist.daps.dla.mil/quicksearch/> or www.dodssp.daps.mil or from the Standardization Document Order Desk, 700 Robbins Avenue, Building 4D, Philadelphia, PA 19111-5094.)

4/ Stresses above the absolute maximum rating may cause permanent damage to the device. Extended operation at the maximum levels may degrade performance and affect reliability.

STANDARD MICROCIRCUIT DRAWING DEFENSE SUPPLY CENTER COLUMBUS COLUMBUS, OHIO 43216-5000	SIZE A		5962-94611
		REVISION LEVEL R	SHEET 4

2.2 Order of precedence. In the event of a conflict between the text of this drawing and the references cited herein, the text of this drawing takes precedence. Nothing in this document, however, supersedes applicable laws and regulations unless a specific exemption has been obtained.

3. REQUIREMENTS

3.1 Item requirements. The individual item performance requirements for device classes D, E, G, H, and K shall be in accordance with MIL-PRF-38534. Compliance with MIL-PRF-38534 shall include the performance of all tests herein or as designated in the device manufacturer's Quality Management (QM) plan or as designated for the applicable device class. The manufacturer may eliminate, modify or optimize the tests and inspections herein, however the performance requirements as defined in MIL-PRF-38534 shall be met for the applicable device class. In addition, the modification in the QM plan shall not affect the form, fit, or function of the device for the applicable device class.

3.2 Design, construction, and physical dimensions. The design, construction, and physical dimensions shall be as specified in MIL-PRF-38534 and herein.

3.2.1 Case outline(s). The case outline(s) shall be in accordance with 1.2.4 herein and figure 1.

3.2.2 Terminal connections. The terminal connections shall be as specified on figure 2.

3.2.3 Truth table(s). The truth table(s) shall be as specified on figure 3.

3.2.4 Timing diagram(s). The timing diagram(s) shall be as specified on figures 4 and 5.

3.2.5 Block diagram. The block diagram shall be as specified on figure 6.

3.2.6 Output load circuit. The output load circuit shall be as specified on figure 7.

3.3 Electrical performance characteristics. Unless otherwise specified herein, the electrical performance characteristics are as specified in table I and shall apply over the full specified operating temperature range.

3.4 Electrical test requirements. The electrical test requirements shall be the subgroups specified in table II. The electrical tests for each subgroup are described in table I.

3.5 Marking of device(s). Marking of device(s) shall be in accordance with MIL-PRF-38534. The device shall be marked with the PIN listed in 1.2 herein. In addition, the manufacturer's vendor similar PIN may also be marked.

3.6 Data. In addition to the general performance requirements of MIL-PRF-38534, the manufacturer of the device described herein shall maintain the electrical test data (variables format) from the initial quality conformance inspection group A lot sample, for each device type listed herein. Also, the data should include a summary of all parameters manually tested, and for those which, if any, are guaranteed. This data shall be maintained under document revision level control by the manufacturer and be made available to the preparing activity (DSCC-VA) upon request.

3.7 Certificate of compliance. A certificate of compliance shall be required from a manufacturer in order to supply to this drawing. The certificate of compliance (original copy) submitted to DSCC-VA shall affirm that the manufacturer's product meets the performance requirements of MIL-PRF-38534 and herein.

3.8 Certificate of conformance. A certificate of conformance as required in MIL-PRF-38534 shall be provided with each lot of microcircuits delivered to this drawing.

STANDARD MICROCIRCUIT DRAWING DEFENSE SUPPLY CENTER COLUMBUS COLUMBUS, OHIO 43216-5000	SIZE A		5962-94611
		REVISION LEVEL R	SHEET 5

TABLE I. Electrical performance characteristics.

Test	Symbol	Conditions <u>1/ 2/</u> -55°C ≤ T _C ≤ +125°C V _{SS} = 0 V dc +4.5 V dc ≤ V _{CC} ≤ +5.5 V dc unless otherwise specified	Group A subgroups	Device types	Limits		Unit
					Min	Max	
DC parameters							
Operating supply current	I _{CC}	$\overline{CS} = V_{IH}, \overline{OE} = V_{IH},$ V _{CC} = 5.5 V dc <u>3/</u> f = 5 MHz f = 5 MHz f = 18.2 MHz f = 22.2 MHz f = 28.6 MHz f = 40 MHz f = 50 MHz f = 58.8 MHz f = 66.67 MHz f = 83.3 MHz	1,2,3	01-04 05-16 05,11 06,12 07,13 08,14 09,15 10,16 17,19 18,20		200 600 625 635 650 675 725 750 200 250	mA
Standby current	I _{SB}	$\overline{CS} = V_{IH}, \overline{OE} = V_{IH},$ V _{CC} = 5.5 V dc <u>3/</u> f = 5 MHz f = 5 MHz f = 18.2 MHz f = 22.2 MHz f = 28.6 MHz f = 40 MHz f = 50 MHz f = 58.8 MHz f = 66.67 MHz f = 83.3 MHz	1,2,3	01-04 05-16 05,11 06,12 07,13 08,14 09,15 10,16 17-20 17-20		4 80 150 150 190 240 280 320 80 80	mA
Input leakage current	I _{LI}	V _{CC} = 5.5 V dc, V _{IN} = GND or V _{CC}	1,2,3	All		10	μA
Output leakage current	I _{LO}	$\overline{CS} = V_{IH}, \overline{OE} = V_{IH},$ V _{IN} = GND or V _{CC}	1,2,3	All		10	μA
Output low voltage	V _{OL}	V _{CC} = +4.5 V dc, I _{OL} = 2.1 mA	1,2,3	01-06, 11,12		0.4	V
		V _{CC} = +4.5 V dc, I _{OL} = 6 mA		07-10, 13-20		0.4	
Output high voltage	V _{OH}	V _{CC} = +4.5 V dc, I _{OH} = -1.0 mA	1,2,3	01-06, 11,12	2.4		V
		V _{CC} = +4.5 V dc, I _{OH} = -4.0 mA		07-10, 13-20	2.4		
See footnotes at end of table.							
STANDARD MICROCIRCUIT DRAWING DEFENSE SUPPLY CENTER COLUMBUS COLUMBUS, OHIO 43216-5000			SIZE A		5962-94611		
					REVISION LEVEL R		SHEET 6

TABLE I. Electrical performance characteristics - Continued.

Test	Symbol	Conditions <u>1/</u> <u>2/</u> -55°C ≤ T _C ≤ +125°C V _{SS} = 0 V dc +4.5 V dc ≤ V _{CC} ≤ +5.5 V dc unless otherwise specified	Group A subgroups	Device types	Limits		Unit
					Min	Max	
Data retention characteristics							
Data retention supply voltage	V _{DR}	$\overline{CS} \geq V_{CC} - 0.2 \text{ V dc}$	1,2,3	01-10	2.0	5.5	V
Data retention current	I _{CCDR1}	V _{CC} = 3 V dc	1,2,3	01-04		1.6	mA
				05-10		28	
				19,20		32	
Capacitance							
\overline{OE} capacitance <u>4/</u>	C _{OE}	V _{IN} = 0 V dc, f = 1.0 MHz, T _A = +25°C	4	All		50	pF
\overline{WE} 1-4 capacitance <u>4/</u>	C _{WE}	V _{OUT} = 0 V dc, f = 1.0 MHz, T _A = +25°C	4	All		20	pF
\overline{CS} capacitance <u>4/</u>	C _{CS}	V _{IN} = 0 V dc, f = 1.0 MHz, T _A = +25°C	4	All		20	pF
D ₀₋₃₁ capacitance <u>4/</u>	C _{I/O}	V _{OUT} = 0 V dc, f = 1.0 MHz, T _A = +25°C	4	All		20	pF
A ₀₋₁₆ capacitance <u>4/</u>	C _{AD}	V _{OUT} = 0 V dc, f = 1.0 MHz, T _A = +25°C	4	All		50	pF
Functional tests							
Functional tests		See 4.3.1c	7,8A,8B	All			
Read cycle timing characteristics							
Read cycle timing	t _{RC}	See figure 4	9,10,11	01 02 03 04 05,11 06,12 07,13 08,14 09,15 10,16 17,19 18,20	120 100 85 70 55 45 35 25 20 17 15 12		ns
See footnotes at end of table.							
STANDARD MICROCIRCUIT DRAWING DEFENSE SUPPLY CENTER COLUMBUS COLUMBUS, OHIO 43216-5000			SIZE A				5962-94611
					REVISION LEVEL R		SHEET 7

TABLE I. Electrical performance characteristics - Continued.

Test	Symbol	Conditions <u>1/ 2/</u> -55°C ≤ T _C ≤ +125°C V _{SS} = 0 V dc +4.5 V dc ≤ V _{CC} ≤ +5.5 V dc unless otherwise specified	Group A subgroups	Device types	Limits		Unit
					Min	Max	
Read cycle timing characteristics - Continued.							
Address access timing	t _{AA}	See figure 4	9,10,11	01 02 03 04 05,11 06,12 07,13 08,14 09,15 10,16 17,19 18,20		120 100 85 70 55 45 35 25 20 17 15 12	ns
Output hold from address change	t _{OH}	See figure 4	9,10,11	01-04 05-10 11-20	5 0 0		ns
Chip select access timing	t _{ACS}	See figure 4	9,10,11	01 02 03 04 05,11 06,12 07,13 08,14 09,15 10,16 17,19 18,20		120 100 85 70 55 45 35 25 20 17 15 12	ns
Output enable to output valid	t _{OE}	See figure 4	9,10,11	01 02 03 04 05-07 11-13 08,14 09,15 10,16 17,19 18,20		60 50 40 35 25 25 12 10 9 8 7	ns
Chip select to output in low impedance <u>4/</u>	t _{CLZ}	See figure 4	9,10,11	01,02 03,04 05-07 11-13 08-10 14-20	10 10 4 4 2 2		ns
See footnote at end of table.							

STANDARD MICROCIRCUIT DRAWING DEFENSE SUPPLY CENTER COLUMBUS COLUMBUS, OHIO 43216-5000	SIZE A		5962-94611
		REVISION LEVEL R	SHEET 8

TABLE I. Electrical performance characteristics - Continued.

Test	Symbol	Conditions <u>1/</u> <u>2/</u> -55°C ≤ T _C ≤ +125°C V _{SS} = 0 V dc +4.5 V dc ≤ V _{CC} ≤ +5.5 V dc unless otherwise specified	Group A subgroups	Device types	Limits		Unit
					Min	Max	
Read cycle timing characteristics - Continued.							
Output enable to output in low impedance <u>4/</u>	t _{OLZ}	See figure 4	9,10,11	01-04 05-20	5 0		ns
Chip select high to output in high impedance <u>4/</u>	t _{CHZ}	See figure 4	9,10,11	01,02 03,04 05,06 11,12 07,13 08-10 14-16 17,19 18,20		35 25 20 20 15 12 12 8 7	ns
Chip enable high to output in high impedance <u>4/</u>	t _{OHZ}	See figure 4	9,10,11	01,02 03,04 05,06 11,12 07,13 08-10 14-16 17,19 18,20		35 25 20 20 15 12 12 8 7	ns
Write cycle AC timing characteristics.							
Write cycle time	t _{wc}	See figure 5	9,10,11	01 02 03 04 05,11 06,12 07,13 08,14 09,15 10,16 17,19 18,20	120 100 85 70 55 45 35 25 20 17 15 12		ns
See footnote at end of table.							
STANDARD MICROCIRCUIT DRAWING DEFENSE SUPPLY CENTER COLUMBUS COLUMBUS, OHIO 43216-5000			SIZE A		5962-94611		
			REVISION LEVEL R		SHEET 9		

TABLE I. Electrical performance characteristics - Continued.

Test	Symbol	Conditions <u>1/</u> <u>2/</u> -55°C ≤ T _C ≤ +125°C V _{SS} = 0 V dc +4.5 V dc ≤ V _{CC} ≤ +5.5 V dc unless otherwise specified	Group A subgroups	Device types	Limits		Unit
					Min	Max	
Write cycle AC timing characteristics - Continued.							
Chip select to end of write	t _{CW}	See figure 5	9,10,11	01 02 03 04 05,11 06,12 07,13 08,14 09,10 15,16 17,19 18,20	120 80 75 60 50 35 30 20 15 15 12 10		ns
Address valid to end of write	t _{AW}	See figure 5	9,10,11	01 02 03 04 05,11 06,12 07,13 08,14 09,10 15,16 17,19 18,20	100 80 75 60 50 35 30 20 15 15 12 10		ns
Data valid to end of write	t _{DW}	See figure 5	9,10,11	01,02 03,04 05,06 11,12 07,13 08,14 09,10 15,16 17,19 18,20	40 30 25 25 20 15 12 12 10 8		ns
Address setup time	t _{AS}	See figure 5	9,10,11	01-04 05-10 11-20	0 2 2		ns
See footnote at end of table.							
STANDARD MICROCIRCUIT DRAWING DEFENSE SUPPLY CENTER COLUMBUS COLUMBUS, OHIO 43216-5000			SIZE A		5962-94611		
					REVISION LEVEL R		SHEET 10

TABLE I. Electrical performance characteristics - Continued.

Test	Symbol	Conditions <u>1/</u> <u>2/</u> -55°C ≤ T _C ≤ +125°C V _{SS} = 0 V dc +4.5 V dc ≤ V _{CC} ≤ +5.5 V dc unless otherwise specified	Group A subgroups	Device types	Limits		Unit
					Min	Max	
Write cycle AC timing characteristics - Continued.							
Write pulse width	t _{WP}	See figure 5	9,10,11	01,02 03,04 05,11 06,12 07,13 08,14 09,10 15,16 17,19 18,20	60 50 40 35 25 17 15 15 12 10		ns
Write enable to output in high impedance <u>4/</u>	t _{WHZ}	See figure 5	9,10,11	01,02 03,04 05,06 11,12 07,13 08,14 09,15 10,16 17,19 18,20		35 25 20 20 15 13 11 9 8 7	ns
Address hold time	t _{AH}	See figure 5	9,10,11	01-06 11,12 07,08 13,14 09,15 17-20 10,16	5 5 2 2 1 1 0		ns
Output active from end of write <u>4/</u>	t _{OW}	See figure 5	9,10,11	01-04 05-20	5 0		ns
Data hold time	t _{DH}	See figure 5	9,10,11	All	0		ns

- 1/ Due to the nature of the 4 transistor design of the die used in these device types, topologically pure testing is important, particularly for high reliability applications. The device manufacturer should be consulted concerning their testing methods and algorithms
- 2/ Unless otherwise specified, the AC test conditions are as follows:
 Input pulse levels: V_{IL} = 0 V and V_{IH} = 3.0 V
 Input rise and fall times: 5 nanoseconds for device types 01-16 and 3 nanoseconds for device types 17-20.
 Input and output timing reference level: 1.5 V ± 0.5 V
 Output loading: see Figure 7.
 Unless otherwise specified, the DC test conditions are as follows:
 V_{IL} = 0.3 V and V_{IH} = V_{CC} - 0.3 V
- 3/ f = 1 / t_{AA}.
- 4/ Parameters shall be tested as part of device characterization and after design and process change. Parameters shall be to the limits specified in table 1 for all lots not specifically tested.

STANDARD MICROCIRCUIT DRAWING DEFENSE SUPPLY CENTER COLUMBUS COLUMBUS, OHIO 43216-5000	SIZE A		5962-94611
		REVISION LEVEL R	SHEET 11

Case outline A.

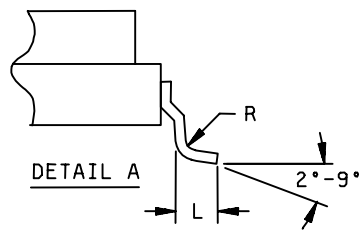
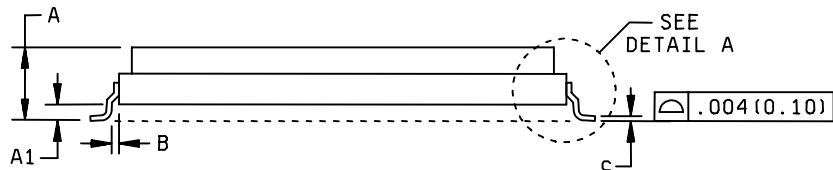
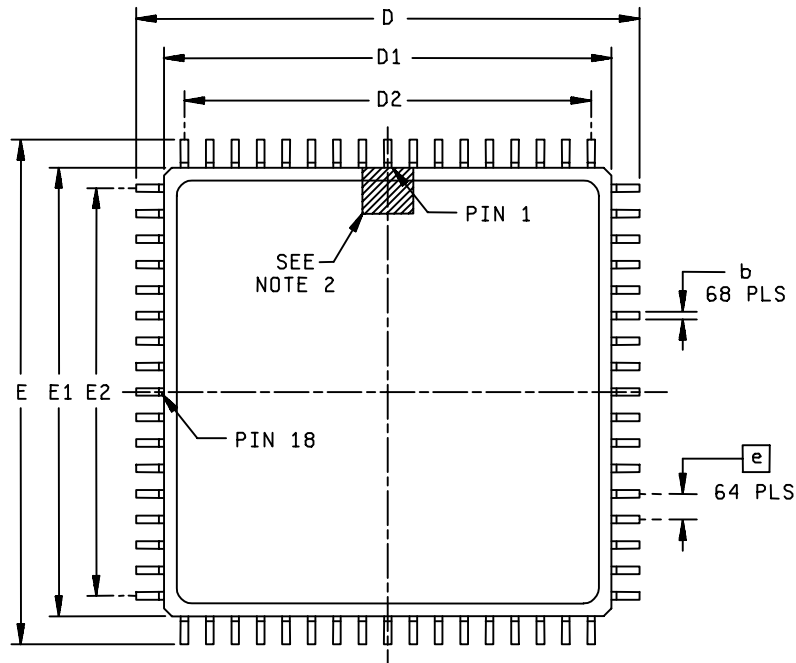

FIGURE 1. Case outlines.

STANDARD MICROCIRCUIT DRAWING DEFENSE SUPPLY CENTER COLUMBUS COLUMBUS, OHIO 43216-5000	SIZE A		5962-94611
		REVISION LEVEL R	SHEET 12

Case outline A - Continued.

Symbol	Millimeters		Inches	
	Min	Max	Min	Max
A		5.10		.200
A1	1.37		.054	
b	0.33	0.43	.013	.017
B	0.25 TYP		.010 TYP	
c	0.23	0.30	.009	.012
D/E	24.9	25.4	.980	1.000
D1/E1	22.10	22.61	.870	.890
D2/E2	20.32 BSC		.800 BSC	
e	1.27 BSC		.050 BSC	
L	0.89	1.14	.035	.045
R	0.25 TYP		.010 TYP	

NOTES:

1. The U.S. preferred system of measurement is the metric SI. This item was designed using inch-pound units of measurement. In case of problems involving conflicts between the metric and inch-pound units, the inch-pound units shall rule.
2. Details of pin 1 identifier are optional, but must be located within the zone indicated.

FIGURE 1. Case outlines - Continued.

STANDARD MICROCIRCUIT DRAWING DEFENSE SUPPLY CENTER COLUMBUS COLUMBUS, OHIO 43216-5000	SIZE A		5962-94611
		REVISION LEVEL R	SHEET 13

Case outline M.

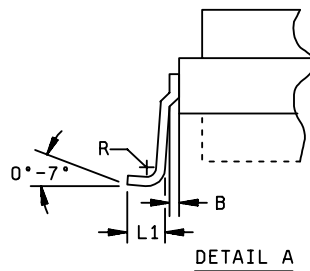
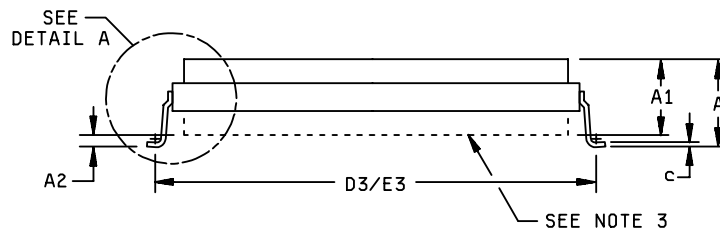
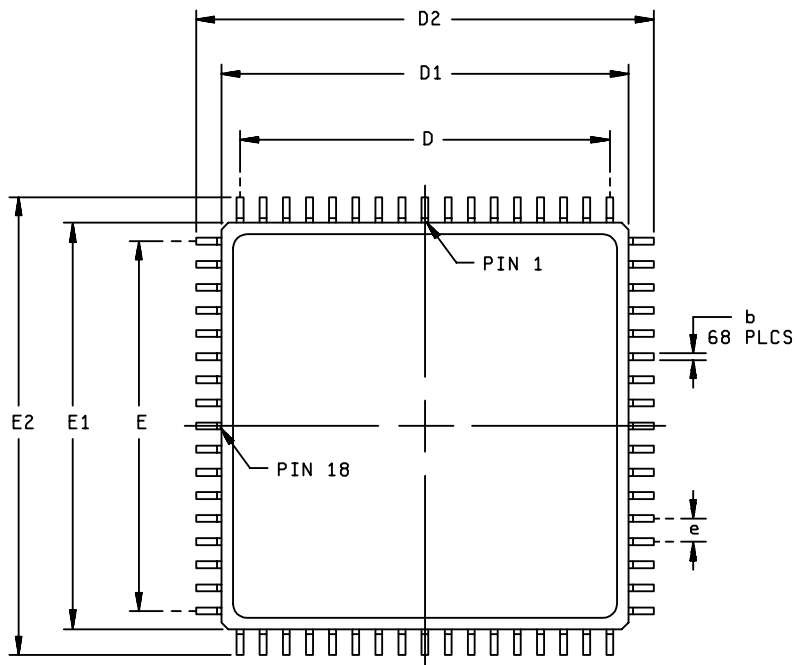

FIGURE 1. Case outline(s).

STANDARD MICROCIRCUIT DRAWING DEFENSE SUPPLY CENTER COLUMBUS COLUMBUS, OHIO 43216-5000	SIZE A		5962-94611
		REVISION LEVEL R	SHEET 14

Case outline M - Continued.

Symbol	Millimeters		Inches	
	Min	Max	Min	Max
A	3.12	5.08	.123	.200
A1	2.30	4.72	.118	.186
A2	0.00	0.64	.000	.025
b	0.33	0.43	.013	.017
B	0.25 REF		.010 REF	
c	0.15	0.30	.006	.012
D/E	20.32 BSC		.800 BSC	
D1/E1	22.10	22.61	.870	.890
D2/E2	24.89	25.40	.980	1.000
D3/E3	23.77	24.28	.936	.956
e	1.27 BSC		.050 BSC	
R	0.13		.005	
L1	0.89	1.14	.035	.045

NOTES:

1. The U.S. preferred system of measurement is the metric SI. This item was designed using inch-pound units of measurement. In case of problems involving conflicts between the metric and inch-pound units, the inch-pound units shall rule.
2. Pin numbers are for reference only.
3. Case outline M may either be a single cavity or a dual cavity package. Dimension A2 is measured between the lowest horizontal plane of the package and the seating plane of the lead(s).

FIGURE 1. Case outline(s) - Continued.

STANDARD MICROCIRCUIT DRAWING DEFENSE SUPPLY CENTER COLUMBUS COLUMBUS, OHIO 43216-5000	SIZE A		5962-94611
		REVISION LEVEL R	SHEET 15

Case outline T.

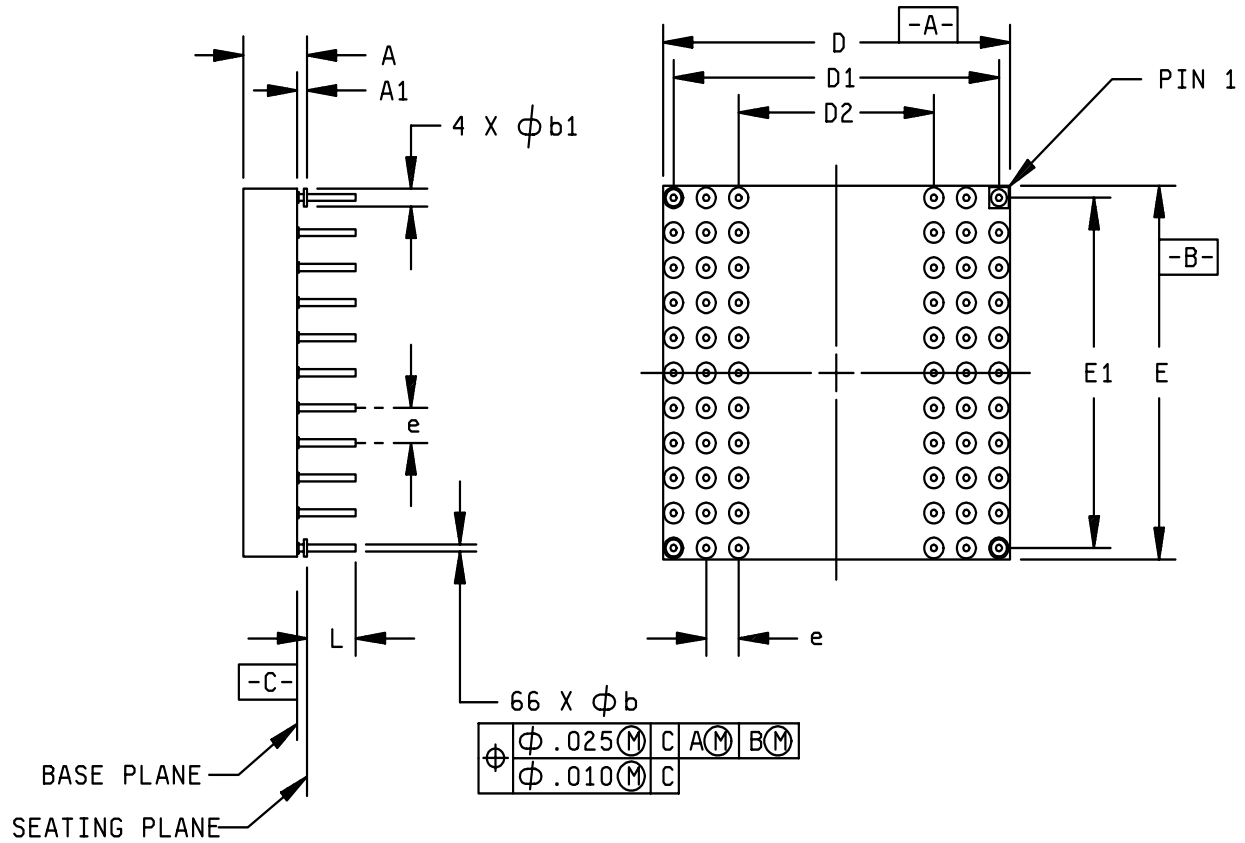

Symbol	Millimeters		Inches	
	Min	Max	Min	Max
A	3.65	4.60	.144	.181
A1	0.64	0.89	.025	.035
ϕb	0.41	0.51	.016	.020
$\phi b1$	1.14	1.40	.045	.055
D/E	27.05	27.55	1.065	1.085
D1/E1	25.40 TYP		1.000 TYP	
D2	15.24 TYP		.600 TYP	
e	2.54 TYP		.100 TYP	
L	3.68	3.94	.145	.155

NOTES:

1. The U.S. preferred system of measurement is the metric SI. This item was designed using inch-pound units of measurement. In case of problems involving conflicts between the metric and inch-pound units, the inch-pound units shall rule.
2. Pin numbers are for reference only.

FIGURE 1. Case outline(s) - Continued.

STANDARD MICROCIRCUIT DRAWING DEFENSE SUPPLY CENTER COLUMBUS COLUMBUS, OHIO 43216-5000	SIZE A		5962-94611
		REVISION LEVEL R	SHEET 16

Case outline U.

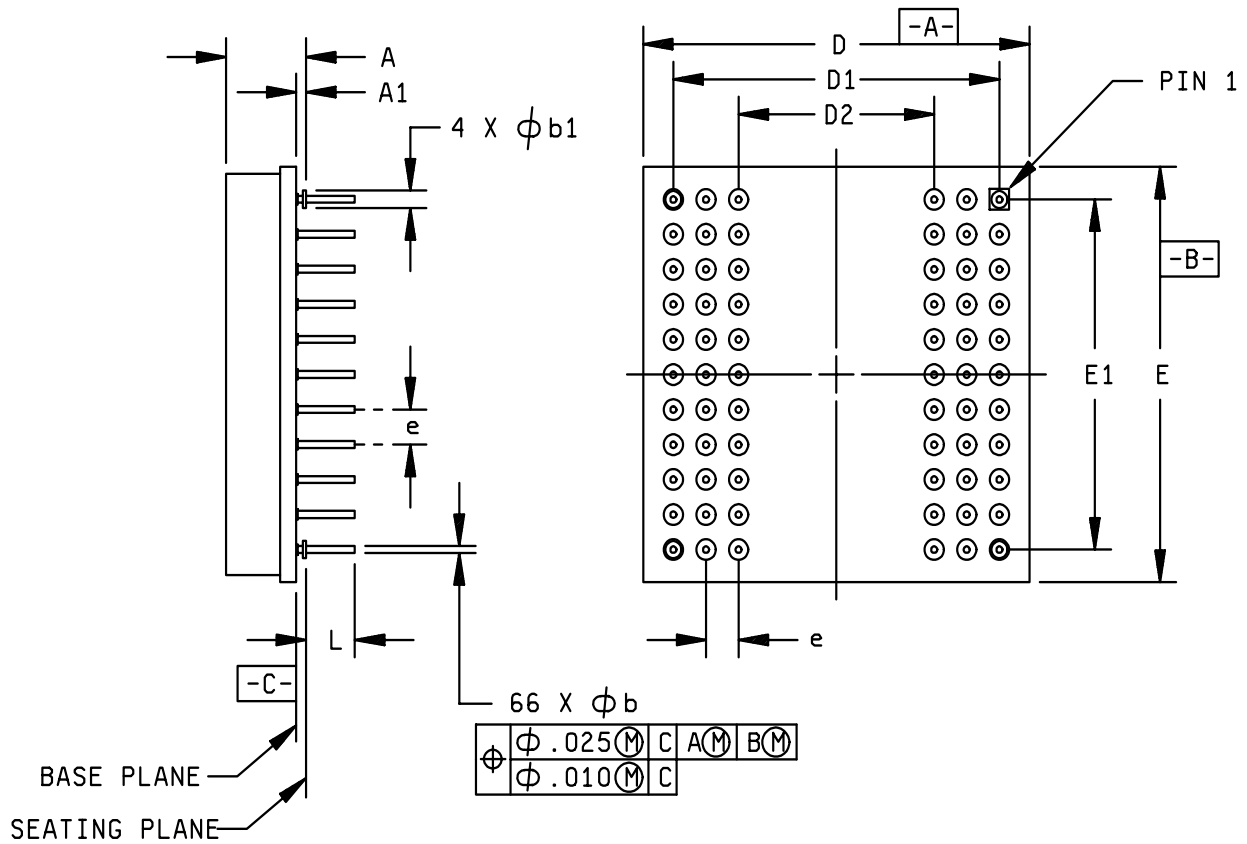

Symbol	Millimeters		Inches	
	Min	Max	Min	Max
A	5.08	6.22	.200	.245
A1	0.64	0.89	.025	.035
ϕb	0.41	0.51	.016	.020
$\phi b1$	1.14	1.40	.045	.055
D/E	29.72	30.48	1.170	1.200
D1/E1	25.40 TYP		1.000 TYP	
D2	15.24 TYP		.600 TYP	
e	2.54 TYP		.100 TYP	
L	3.68	3.94	.145	.155

NOTES:

1. The U.S. preferred system of measurement is the metric SI. This item was designed using inch-pound units of measurement. In case of problems involving conflicts between the metric and inch-pound units, the inch-pound units shall rule.
2. Pin numbers are for reference only.

FIGURE 1. Case outline(s) - Continued.

STANDARD MICROCIRCUIT DRAWING DEFENSE SUPPLY CENTER COLUMBUS COLUMBUS, OHIO 43216-5000	SIZE A		5962-94611
		REVISION LEVEL R	SHEET 17

Case outline X.

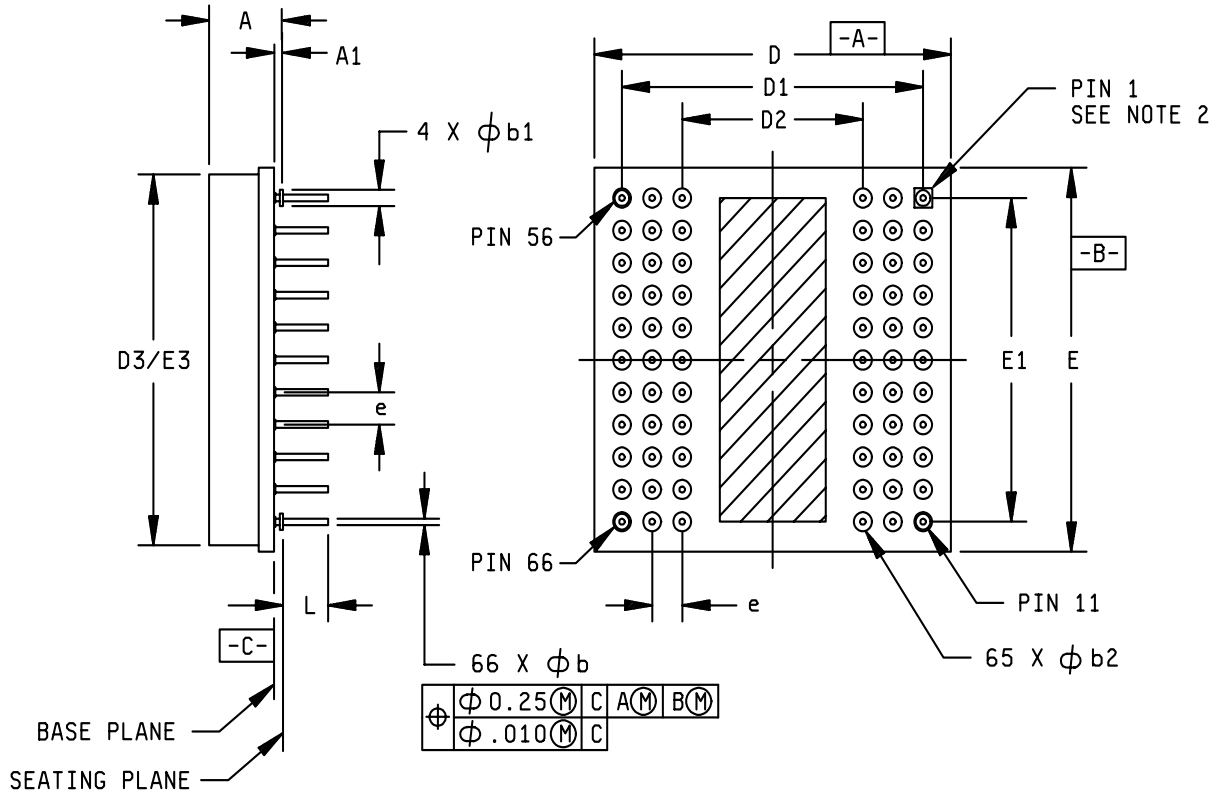

Symbol	Millimeters		Inches	
	Min	Max	Min	Max
A	4.83	6.22	.190	.245
A1	0.64	0.89	.025	.035
ϕb	0.41	0.51	.016	.020
$\phi b1$	1.14	1.40	.045	.055
$\phi b2$	1.65	1.91	.065	.075
D/E	34.80	35.56	1.370	1.400
D1/E1	25.40 TYP		1.000 TYP	
D2	15.24 TYP		.600 TYP	
D3/E3	34.04	34.29	1.340	1.350
e	2.54 TYP		.100 TYP	
L	3.68	3.94	.145	.155

NOTES:

1. The U.S. preferred system of measurement is the metric SI. This item was designed using inch-pound units of measurement. In case of problems involving conflicts between the metric and inch-pound units, the inch-pound units shall rule.
2. Pin numbers are for reference only. Pin 1 is identified by .070 " square pad.
3. For solder lead finish, dimension ϕb will increase by +.003" (+0.008 mm).

FIGURE 1. Case outline(s) - Continued.

STANDARD MICROCIRCUIT DRAWING DEFENSE SUPPLY CENTER COLUMBUS COLUMBUS, OHIO 43216-5000	SIZE A		5962-94611
		REVISION LEVEL R	SHEET 18

Case outline Y.

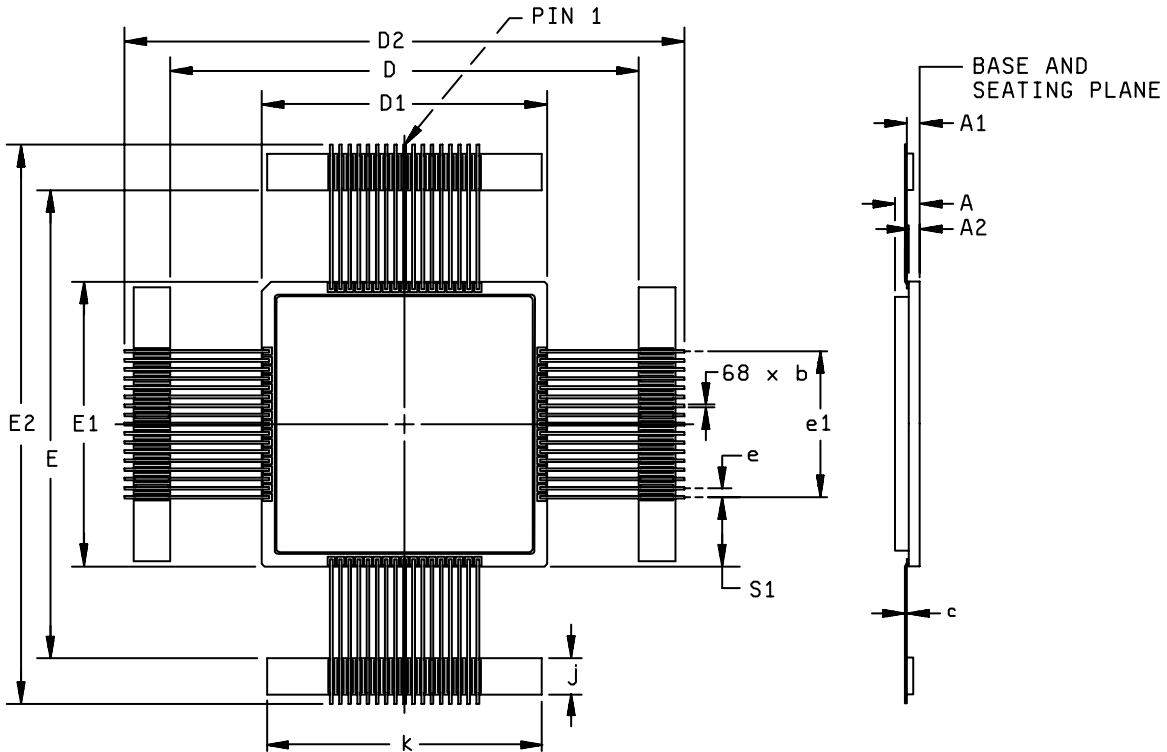

Symbol	Millimeters		Inches	
	Min	Max	Min	Max
A	2.92	3.56	.115	.140
A1	1.14	1.91	.045	.075
A2	1.14	1.39	.045	.055
b	0.31	0.46	.012	.018
c	0.23	0.31	.009	.012
D/E	63.63	66.42	2.505	2.615
D1/E1	39.24	40.01	1.545	1.575
D2/E2	73.28	84.20	2.885	3.315
e	1.27 BSC		.050 BSC	
e1	20.32 BSC		.800 BSC	
j	4.83	5.33	.190	.210
k	37.72	38.48	1.485	1.515
S1	9.65 BSC		.380 BSC	

NOTES:

1. The U.S. preferred system of measurement is the metric SI. This item was designed using inch-pound units of measurement. In case of problems involving conflicts between the metric and inch-pound units, the inch-pound units shall rule.
2. Pin numbers are for reference only.
3. For solder lead finish, dimension b will increase by +.003" (+0.008 mm).

FIGURE 1. Case outline(s) - Continued.

STANDARD MICROCIRCUIT DRAWING DEFENSE SUPPLY CENTER COLUMBUS COLUMBUS, OHIO 43216-5000	SIZE A		5962-94611
		REVISION LEVEL R	SHEET 19

Case outline B.

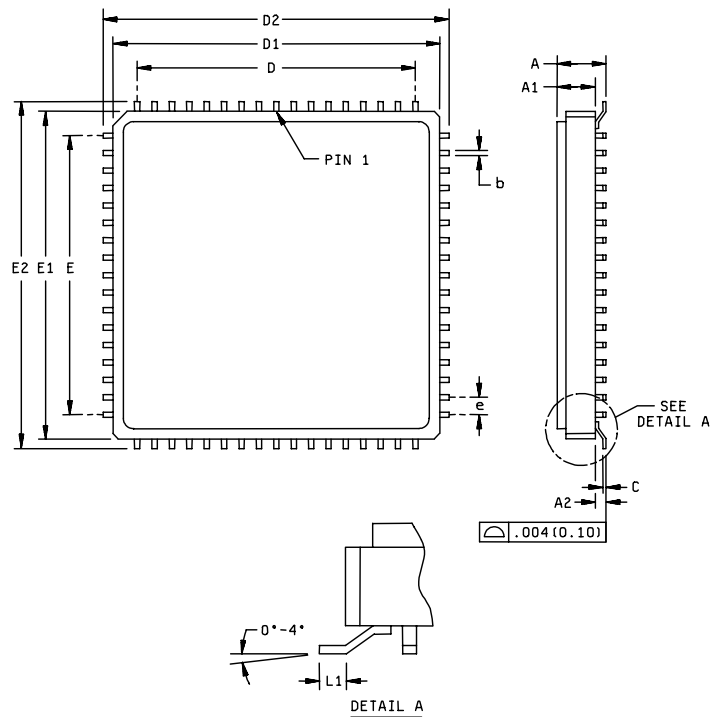

Symbol	Millimeters		Inches	
	Min	Max	Min	Max
A		4.06		.160
A1		2.79		.110
A2	1.12	1.42	.044	.056
b	0.33	0.43	.013	.017
C	0.15	0.25	.006	.010
D/E	20.32 BSC		.800 BSC	
D1/E1	23.65	24.10	.931	.949
D2/E2	24.89	25.40	.980	1.000
e	1.27 BSC		.050 BSC	
L1	0.51	1.14	.020	.045

NOTES:

1. The U.S. preferred system of measurement is the metric SI. This item was designed using inch-pound units of measurement. In case of problems involving conflicts between the metric and inch-pound units, the inch-pound units shall rule.
2. Pin numbers are for reference only.

FIGURE 1. Case outline(s) - Continued.

STANDARD MICROCIRCUIT DRAWING DEFENSE SUPPLY CENTER COLUMBUS COLUMBUS, OHIO 43216-5000	SIZE A		5962-94611
		REVISION LEVEL R	SHEET 20

Case outline 9.

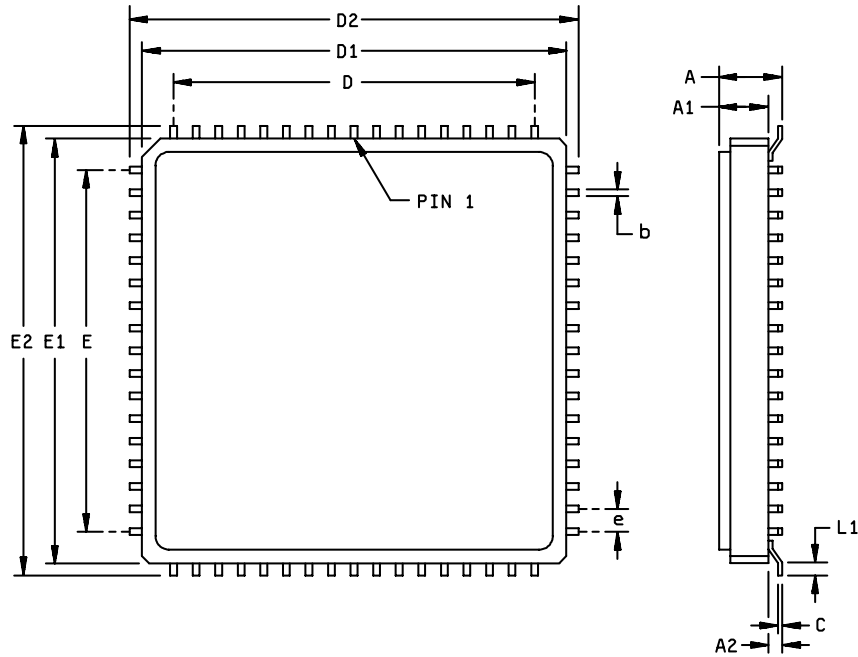

Symbol	Millimeters		Inches	
	Min	Max	Min	Max
A		3.56		.140
A1		2.79		.110
A2	0.46	0.76	.018	.030
b	0.33	0.43	.013	.017
C	0.15	0.25	.006	.010
D/E	20.32 BSC		.800 BSC	
D1/E1	23.65	24.10	.931	.949
D2/E2	24.89	25.40	.980	1.000
e	1.27 BSC		.050 BSC	
L1	0.51	1.14	.020	.045

NOTES:

1. The U.S. preferred system of measurement is the metric SI. This item was designed using inch-pound units of measurement. In case of problems involving conflicts between the metric and inch-pound units, the inch-pound units shall rule.
2. Pin numbers are for reference only.

FIGURE 1. Case outline(s) - Continued.

STANDARD MICROCIRCUIT DRAWING DEFENSE SUPPLY CENTER COLUMBUS COLUMBUS, OHIO 43216-5000	SIZE A		5962-94611
		REVISION LEVEL R	SHEET 21

Device types	All	Device types	All	Device types	All	Device types	All
Case outlines	A, B, M, 9	Case outlines	A, B, M, 9	Case outlines	A, B, M, 9	Case outlines	A, B, M, 9
Terminal number	Terminal symbol	Terminal number	Terminal symbol	Terminal number	Terminal symbol	Terminal number	Terminal symbol
1	GND	18	GND	35	\overline{OE}	52	GND
2	$\overline{CS3}$	19	I/O8	36	$\overline{CS2}$	53	I/O23
3	A5	20	I/O9	37	A17	54	I/O22
4	A4	21	I/O10	38	$\overline{WE2}$	55	I/O21
5	A3	22	I/O11	39	$\overline{WE3}$	56	I/O20
6	A2	23	I/O12	40	$\overline{WE4}$	57	I/O19
7	A1	24	I/O13	41	A18	58	I/O18
8	A0	25	I/O14	42	NC	59	I/O17
9	NC	26	I/O15	43	NC	60	I/O16
10	I/O0	27	V _{cc}	44	I/O31	61	V _{cc}
11	I/O1	28	A11	45	I/O30	62	A10
12	I/O2	29	A12	46	I/O29	63	A9
13	I/O3	30	A13	47	I/O28	64	A8
14	I/O4	31	A14	48	I/O27	65	A7
15	I/O5	32	A15	49	I/O26	66	A6
16	I/O6	33	A16	50	I/O25	67	$\overline{WE1}$
17	I/O7	34	$\overline{CS1}$	51	I/O24	68	$\overline{CS4}$

FIGURE 2. Terminal connections.

STANDARD MICROCIRCUIT DRAWING DEFENSE SUPPLY CENTER COLUMBUS COLUMBUS, OHIO 43216-5000	SIZE A		5962-94611
		REVISION LEVEL R	SHEET 22

Device types	All	Device types	All	Device types	All	Device types	All
Case outline	T, U, X	Case outline	T, U, X	Case outline	T, U, X	Case outline	T, U, X
Terminal number	Terminal symbol	Terminal number	Terminal symbol	Terminal number	Terminal symbol	Terminal number	Terminal symbol
1	I/O8	18	A12	35	I/O25	52	$\overline{WE3}$
2	I/O9	19	V _{CC}	36	I/O26	53	$\overline{CS3}$
3	I/O10	20	$\overline{CS1}$	37	A6	54	GND
4	A13	21	NC	38	A7	55	I/O19
5	A14	22	I/O3	39	NC	56	I/O31
6	A15	23	I/O15	40	A8	57	I/O30
7	A16	24	I/O14	41	A9	58	I/O29
8	A17	25	I/O13	42	I/O16	59	I/O28
9	I/O0	26	I/O12	43	I/O17	60	A0
10	I/O1	27	\overline{OE}	44	I/O18	61	A1
11	I/O2	28	A18	45	V _{CC}	62	A2
12	$\overline{WE2}$	29	$\overline{WE1}$	46	$\overline{CS4}$	63	I/O23
13	$\overline{CS2}$	30	I/O7	47	$\overline{WE4}$	64	I/O22
14	GND	31	I/O6	48	I/O27	65	I/O21
15	I/O11	32	I/O5	49	A3	66	I/O20
16	A10	33	I/O4	50	A4		
17	A11	34	I/O24	51	A5		

FIGURE 2. Terminal connections - Continued.

STANDARD MICROCIRCUIT DRAWING DEFENSE SUPPLY CENTER COLUMBUS COLUMBUS, OHIO 43216-5000	SIZE A		5962-94611
		REVISION LEVEL R	SHEET 23

Device types	All	Device types	All	Device types	All	Device types	All
Case outline	Y	Case outline	Y	Case outline	Y	Case outline	Y
Terminal number	Terminal symbol	Terminal number	Terminal symbol	Terminal number	Terminal symbol	Terminal number	Terminal symbol
1	GND	18	GND	35	$\overline{\text{OE}}$	52	GND
2	$\overline{\text{CS1}}$	19	I/O8	36	$\overline{\text{CS4}}$	53	I/O23
3	A5	20	I/O9	37	A17	54	I/O22
4	A4	21	I/O10	38	A18	55	I/O21
5	A3	22	I/O11	39	NC	56	I/O20
6	A2	23	I/O12	40	NC	57	I/O19
7	A1	24	I/O13	41	NC	58	I/O18
8	A0	25	I/O14	42	NC	59	I/O17
9	NC	26	I/O15	43	NC	60	I/O16
10	I/O0	27	V _{CC}	44	I/O31	61	V _{CC}
11	I/O1	28	A11	45	I/O30	62	A10
12	I/O2	29	A12	46	I/O29	63	A9
13	I/O3	30	A13	47	I/O28	64	A8
14	I/O4	31	A14	48	I/O27	65	A7
15	I/O5	32	A15	49	I/O26	66	A6
16	I/O6	33	A16	50	I/O25	67	$\overline{\text{WE}}$
17	I/O7	34	$\overline{\text{CS2}}$	51	I/O24	68	$\overline{\text{CS3}}$

FIGURE 2. Terminal connections - Continued.

STANDARD MICROCIRCUIT DRAWING DEFENSE SUPPLY CENTER COLUMBUS COLUMBUS, OHIO 43216-5000	SIZE A		5962-94611
		REVISION LEVEL R	SHEET 24

\overline{CS}	\overline{OE}	\overline{WE}	I/O	MODE
V_{IL}	V_{IL}	V_{IH}	D _{OUT}	Read
V_{IH}	X	X	High Z	Standby
V_{IL}	V_{IH}	V_{IH}	High Z	Output disable
V_{IL}	V_{IH}	V_{IL}	D _{IN}	Write

NOTES:

1. V_{IH} = High logic level
2. V_{IL} = Low logic level
3. X = Do not care (either high or low)
4. High Z = High impedance state

FIGURE 3. Truth table.

STANDARD MICROCIRCUIT DRAWING DEFENSE SUPPLY CENTER COLUMBUS COLUMBUS, OHIO 43216-5000	SIZE A		5962-94611
		REVISION LEVEL R	SHEET 25

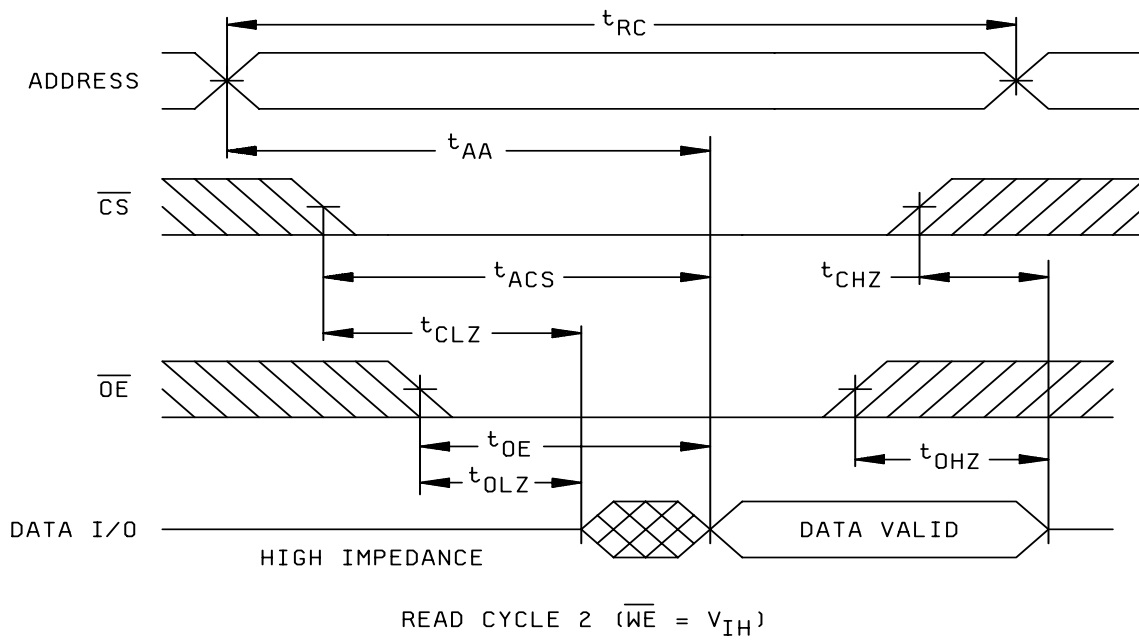
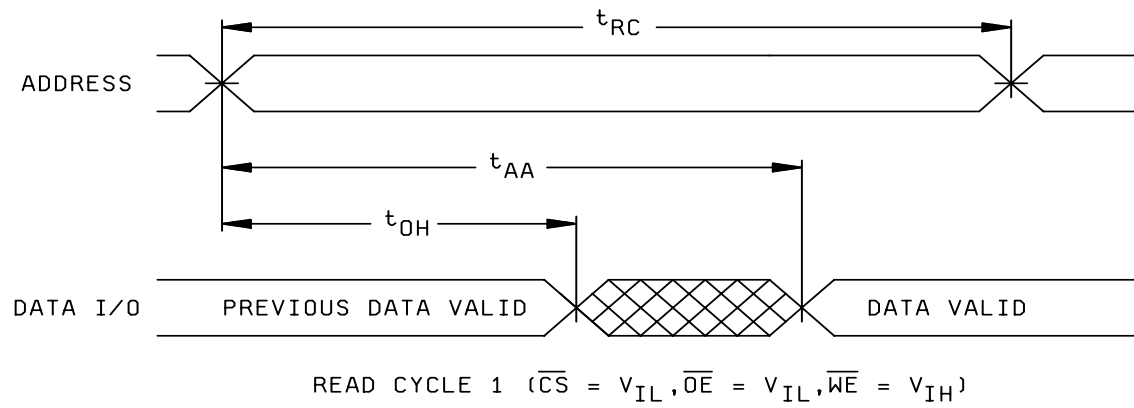

FIGURE 4. Read cycle timing diagram.

**STANDARD
MICROCIRCUIT DRAWING**

DEFENSE SUPPLY CENTER COLUMBUS
COLUMBUS, OHIO 43216-5000

SIZE
A

5962-94611

REVISION LEVEL
R

SHEET
26

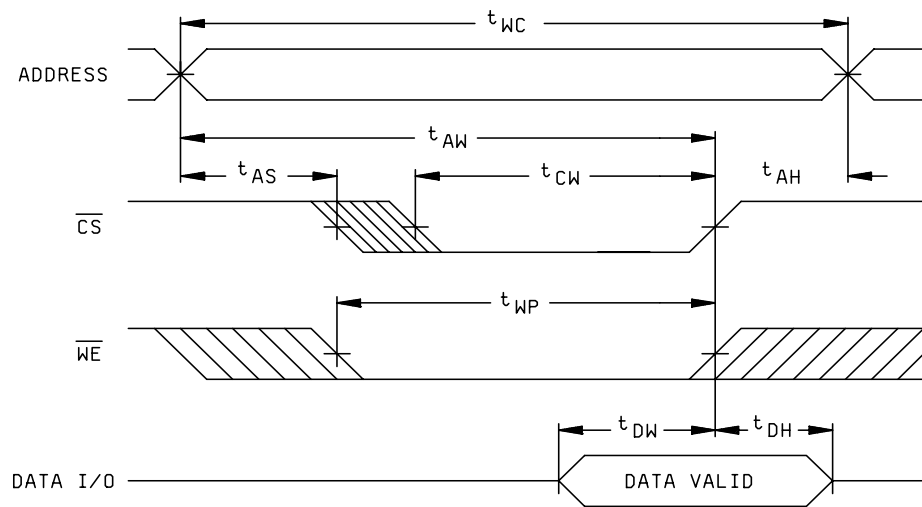
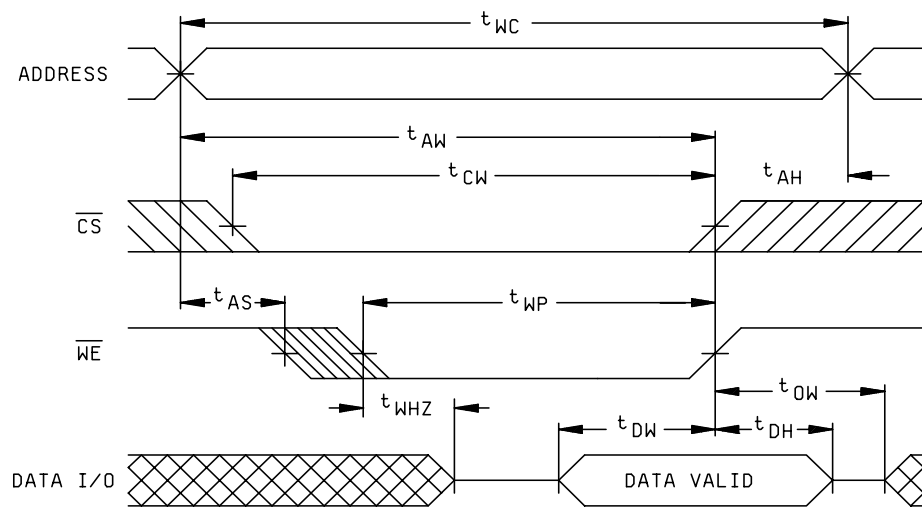
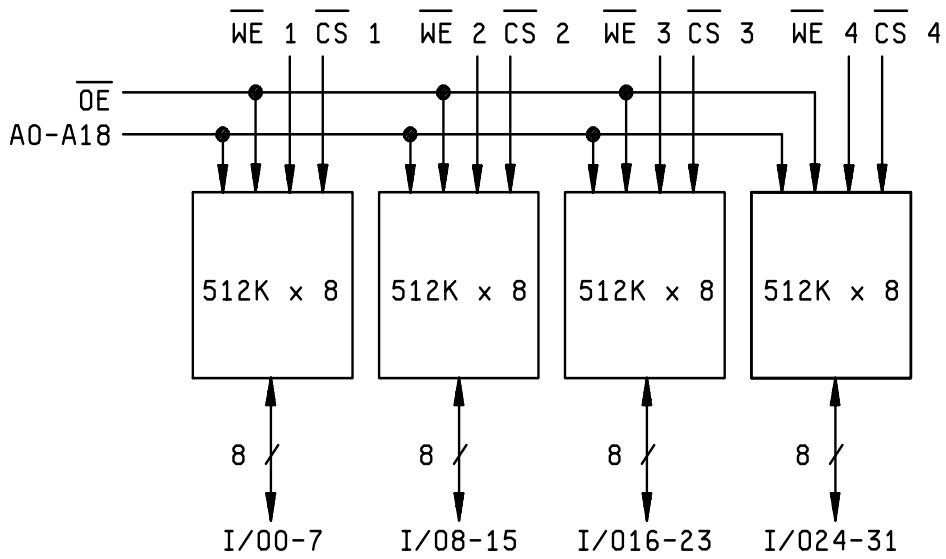

FIGURE 5. Write cycle timing diagram.

STANDARD MICROCIRCUIT DRAWING DEFENSE SUPPLY CENTER COLUMBUS COLUMBUS, OHIO 43216-5000	SIZE A		5962-94611
		REVISION LEVEL R	SHEET 27

Case outlines A, B, M, T, U, X, and 9.



Case outline Y.

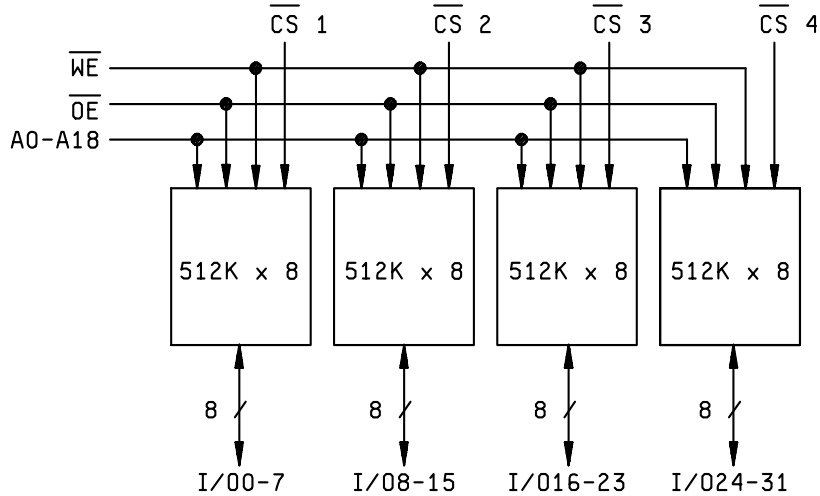
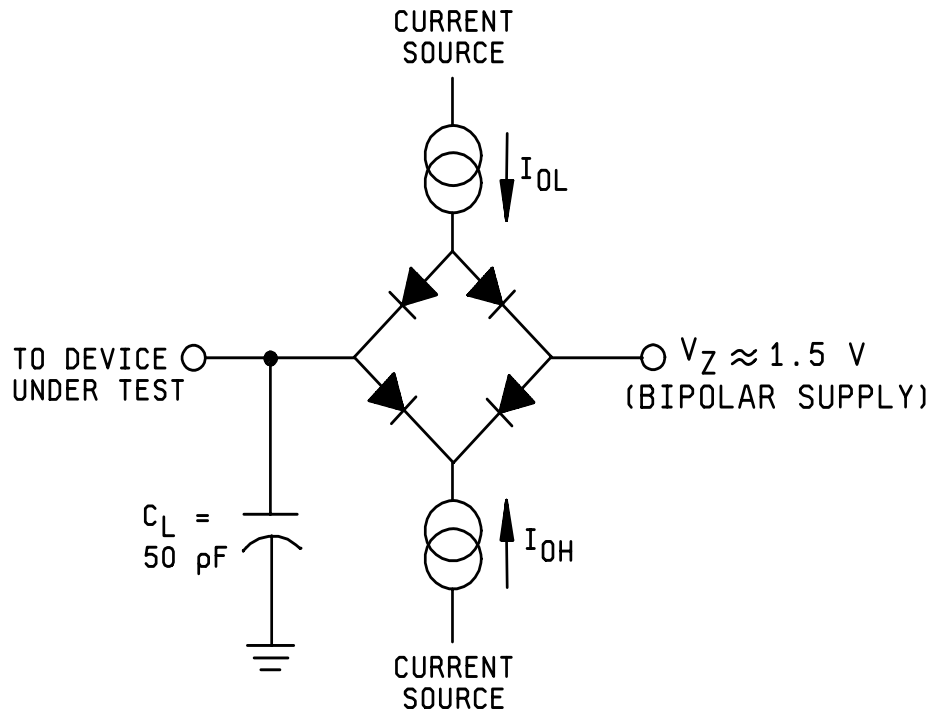

FIGURE 6. Block diagram(s).

STANDARD MICROCIRCUIT DRAWING DEFENSE SUPPLY CENTER COLUMBUS COLUMBUS, OHIO 43216-5000	SIZE A		5962-94611
		REVISION LEVEL R	SHEET 28



Parameter	Typical	Unit
Input pulse level	0 - 3.0	V
Input rise and fall	5	ns
Input and output reference level	1.5	V
Output load capacitance	50	pF

NOTES:

1. V_Z is programmable from -2 V to +7 V
2. I_{OL} and I_{OH} are programmable from 0 to 16 mA.
3. Tester impedance is $Z_0 = 75$ ohms.
4. V_Z is typically the midpoint of V_{OL} and V_{OH} .
5. I_{OL} and I_{OH} are adjusted to simulate a typical resistive load circuit.
6. ATE tester includes jig capacitance.

FIGURE 7. Output load circuit.

STANDARD MICROCIRCUIT DRAWING DEFENSE SUPPLY CENTER COLUMBUS COLUMBUS, OHIO 43216-5000	SIZE A		5962-94611
		REVISION LEVEL R	SHEET 29

TABLE II. Electrical test requirements.

MIL-PRF-38534 test requirements	Subgroups (in accordance with MIL-PRF-38534, group A test table)
Interim electrical parameters	1,4,7,9
Final electrical parameters	1*,2,3,4,7,8A,8B,9,10,11
Group A test requirements	1,2,3,4,7,8A,8B,9,10,11
Group C end-point electrical Parameters	1,2,3,4,7,8A,8B,9,10,11
End-point electrical parameters for Radiation Hardness Assurance (RHA) devices	Not applicable.

* PDA applies to subgroup 1.

4. VERIFICATION

4.1 Sampling and inspection. Sampling and inspection procedures shall be in accordance with MIL-PRF-38534 or as modified in the device manufacturer's Quality Management (QM) plan. The modification in the QM plan shall not affect the form, fit, or function as described herein.

4.2 Screening. Screening shall be in accordance with MIL-PRF-38534. The following additional criteria shall apply:

a. Burn-in test, method 1015 of MIL-STD-883.

- (1) Test condition B. The test circuit shall be maintained by the manufacturer under document revision level control and shall be made available to either DSCC-VA or the acquiring activity upon request. Also, the test circuit shall specify the inputs, outputs, biases, and power dissipation, as applicable, in accordance with the intent specified in method 1015 of MIL-STD-883.
- (2) T_A as specified in accordance with table I of method 1015 of MIL-STD-883.

b. Interim and final electrical test parameters shall be as specified in table II herein, except interim electrical parameter tests prior to burn-in are optional at the discretion of the manufacturer.

4.3 Conformance and periodic inspections. Conformance inspection (CI) and periodic inspection (PI) shall be in accordance with MIL-PRF-38534 and as specified herein.

4.3.1 Group A inspection (CI). Group A inspection shall be in accordance with MIL-PRF-38534 and as follows:

- a. Tests shall be as specified in table II herein.
- b. Subgroups 5 and 6 shall be omitted.
- c. Subgroups 7 and 8 shall include verification of the truth table on figure 3.

4.3.2 Group B inspection (PI). Group B inspection shall be in accordance with MIL-PRF-38534.

STANDARD MICROCIRCUIT DRAWING DEFENSE SUPPLY CENTER COLUMBUS COLUMBUS, OHIO 43216-5000	SIZE A		5962-94611
		REVISION LEVEL R	SHEET 30

4.3.3 Group C inspection (PI). Group C inspection shall be in accordance with MIL-PRF-38534 and as follows:

- a. End-point electrical parameters shall be as specified in table II herein.
- b. Steady-state life test, method 1005 of MIL-STD-883.
 - (1) Test condition B. The test circuit shall be maintained by the manufacturer under document revision level control and shall be made available to either DSCC-VA or the acquiring activity upon request. Also, the test circuit shall specify the inputs, outputs, biases, and power dissipation, as applicable, in accordance with the intent specified in method 1005 of MIL-STD-883.
 - (2) T_A as specified in accordance with table I of method 1005 of MIL-STD-883.
 - (3) Test duration: 1,000 hours, except as permitted by method 1005 of MIL-STD-883.

4.3.4 Group D inspection (PI). Group D inspection shall be in accordance with MIL-PRF-38534.

4.3.5 Radiation hardness assurance (RHA) inspection. RHA inspection is currently not applicable to this drawing.

5. PACKAGING

5.1 Packaging requirements. The requirements for packaging shall be in accordance with MIL-PRF-38534.

6. NOTES

6.1 Intended use. Microcircuits conforming to this drawing are intended for use for Government microcircuit applications (original equipment), design applications, and logistics purposes.

6.2 Replaceability. Microcircuits covered by this drawing will replace the same generic device covered by a contractor-prepared specification or drawing.

6.3 Configuration control of SMD's. All proposed changes to existing SMD's will be coordinated as specified in MIL-PRF-38534.

6.4 Record of users. Military and industrial users shall inform Defense Supply Center Columbus (DSCC) when a system application requires configuration control and the applicable SMD. DSCC will maintain a record of users and this list will be used for coordination and distribution of changes to the drawings. Users of drawings covering microelectronic devices (FSC 5962) should contact DSCC-VA, telephone (614) 692-0544.

6.5 Comments. Comments on this drawing should be directed to DSCC-VA, Columbus, Ohio 43216-5000, or telephone (614) 692-1081.

6.6 Sources of supply. Sources of supply are listed in MIL-HDBK-103 and QML-38534. The vendors listed in MIL-HDBK-103 and QML-38534 have submitted a certificate of compliance (see 3.7 herein) to DSCC-VA and have agreed to this drawing.

STANDARD MICROCIRCUIT DRAWING DEFENSE SUPPLY CENTER COLUMBUS COLUMBUS, OHIO 43216-5000	SIZE A		5962-94611
		REVISION LEVEL R	SHEET 31

STANDARD MICROCIRCUIT DRAWING BULLETIN

DATE: 04-05-03

Approved sources of supply for SMD 5962-94611 are listed below for immediate acquisition information only and shall be added to MIL-HDBK-103 and QML-38534 during the next revision. MIL-HDBK-103 and QML-38534 will be revised to include the addition or deletion of sources. The vendors listed below have agreed to this drawing and a certificate of compliance has been submitted to and accepted by DSCC-VA. This information bulletin is superseded by the next dated revision of MIL-HDBK-103 and QML-38534.

Standard microcircuit drawing PIN <u>1</u> /	Vendor CAGE number	Vendor similar PIN <u>2</u> /
5962-9461101HMA 5962-9461101HMC 5962-9461101HXA 5962-9461101HXC 5962-9461101HYC 5962-9461101HUA 5962-9461101HUC	54230 54230 <u>3</u> / <u>3</u> / 54230 54230 54230	WS512K32-120G2Q WS512K32-120G2Q WS512K32N-120H2Q WS512K32N-120H2Q WS512K32-120G4TQ WS512K32N-120HQ WS512K32N-120HQ
5962-9461102HMA 5962-9461102HMC 5962-9461102HXA 5962-9461102HXC 5962-9461102HYC 5962-9461102HUA 5962-9461102HUC	54230 54230 <u>3</u> / <u>3</u> / 54230 54230 54230	WS512K32-100G2Q WS512K32-100G2Q WS512K32N-100H2Q WS512K32N-100H2Q WS512K32-100G4TQ WS512K32N-100HQ WS512K32N-100HQ
5962-9461103HMA 5962-9461103HMC 5962-9461103HXA 5962-9461103HXC 5962-9461103HYC 5962-9461103HUA 5962-9461103HUC	54230 54230 <u>3</u> / <u>3</u> / 54230 54230 54230	WS512K32-85G2Q WS512K32-85G2Q WS512K32N-85H2Q WS512K32N-85H2Q WS512K32-85G4TQ WS512K32N-85HQ WS512K32N-85HQ
5962-9461104HMA 5962-9461104HMC 5962-9461104HXA 5962-9461104HXC 5962-9461104HYC 5962-9461104HUA 5962-9461104HUC	54230 54230 <u>3</u> / <u>3</u> / 54230 54230 54230	WS512K32-70G2Q WS512K32-70G2Q WS512K32N-70H2Q WS512K32N-70H2Q WS512K32-70G4TQ WS512K32N-70HQ WS512K32N-70HQ

See footnotes at end of table.

STANDARD MICROCIRCUIT DRAWING BULLETIN - Continued.

DATE: 04-05-03

Standard microcircuit drawing PIN 1/	Vendor CAGE number	Vendor similar PIN 2/
5962-9461105HAA	0EU86	AS8S512K32Q1-55L/883C
5962-9461105HAC	0EU86	AS8S512K32Q1-55L/883C
5962-9461105HAA	54230	WS512K32-55G2LQ
5962-9461105HAC	54230	WS512K32-55G2LQ
5962-9461105HMA	0EU86	AS8S512K32Q-55L/Q
5962-9461105HMC	0EU86	AS8S512K32Q-55L/Q
5962-9461105HMA	54230	WS512K32-55G2Q
5962-9461105HMC	54230	WS512K32-55G2Q
5962-9461105HMA	88379	ACT-S512K32N-055F2Q
5962-9461105HMC	88379	ACT-S512K32N-055F2Q
5962-9461105HTA	0EU86	AS8S512K32P-55L/Q
5962-9461105HTC	0EU86	AS8S512K32P-55L/Q
5962-9461105HTA	54230	WS512K32N-55H1Q
5962-9461105HTC	54230	WS512K32N-55H1Q
5962-9461105HTA	88379	ACT-S512K32N-055P7Q
5962-9461105HTC	88379	ACT-S512K32N-055P7Q
5962-9461105HXA	3/	WS512K32N-55H2Q
5962-9461105HXC	3/	WS512K32N-55H2Q
5962-9461105HXA	88379	ACT-S512K32N-055P1Q
5962-9461105HXC	88379	ACT-S512K32N-055P1Q
5962-9461105HYA	88379	ACT-S512K32N-055F1Q
5962-9461105HYC	88379	ACT-S512K32N-055F1Q
5962-9461105HYC	54230	WS512K32-55G4TQ
5962-9461105H9A	54230	WS512K32-55G1UQ
5962-9461105H9C	54230	WS512K32-55G1UQ
5962-9461105H9A	88379	ACT-S512K32N-055F18Q
5962-9461105H9C	88379	ACT-S512K32N-055F18Q
5962-9461105HBA	54230	WS512K32-55G1TQ
5962-9461105HBC	54230	WS512K32-55G1TQ
5962-9461106HAA	0EU86	AS8S512K32Q1-45L/883C
5962-9461106HAC	0EU86	AS8S512K32Q1-45L/883C
5962-9461106HAA	54230	WS512K32-45G2LQ
5962-9461106HAC	54230	WS512K32-45G2LQ
5962-9461106HMA	0EU86	AS8S512K32Q-45L/Q
5962-9461106HMC	0EU86	AS8S512K32Q-45L/Q
5962-9461106HMA	54230	WS512K32-45G2Q
5962-9461106HMC	54230	WS512K32-45G2Q
5962-9461106HMA	88379	ACT-S512K32N-045F2Q
5962-9461106HMC	88379	ACT-S512K32N-045F2Q
5962-9461106HTA	0EU86	AS8S512K32P-45L/Q
5962-9461106HTC	0EU86	AS8S512K32P-45L/Q
5962-9461106HTA	54230	WS512K32N-45H1Q
5962-9461106HTC	54230	WS512K32N-45H1Q
5962-9461106HTA	88379	ACT-S512K32N-045P7Q
5962-9461106HTC	88379	ACT-S512K32N-045P7Q
5962-9461106HXA	3/	WS512K32N-45H2Q
5962-9461106HXC	3/	WS512K32N-45H2Q
5962-9461106HXA	88379	ACT-S512K32N-045P1Q
5962-9461106HXC	88379	ACT-S512K32N-045P1Q
5962-9461106HYA	88379	ACT-S512K32N-045F1Q
5962-9461106HYC	88379	ACT-S512K32N-045F1Q
5962-9461106HYC	54230	WS512K32-45G4TQ
5962-9461106H9A	54230	WS512K32-45G1UQ
5962-9461106H9C	54230	WS512K32-45G1UQ
5962-9461106H9A	88379	ACT-S512K32N-045F18Q
5962-9461106H9C	88379	ACT-S512K32N-045F18Q
5962-9461106HBA	54230	WS512K32-45G1TQ
5962-9461106HBC	54230	WS512K32-45G1TQ

See footnotes at end of table.

STANDARD MICROCIRCUIT DRAWING BULLETIN - Continued.

DATE: 04-05-03

Standard microcircuit drawing PIN <u>1/</u>	Vendor CAGE number	Vendor similar PIN <u>2/</u>
5962-9461107HAA	0EU86	AS8S512K32Q1-35L/883C
5962-9461107HAC	0EU86	AS8S512K32Q1-35L/883C
5962-9461107HAA	54230	WS512K32-35G2LQ
5962-9461107HAC	54230	WS512K32-35G2LQ
5962-9461107HMA	0EU86	AS8S512K32Q-35L/Q
5962-9461107HMC	0EU86	AS8S512K32Q-35L/Q
5962-9461107HMA	54230	WS512K32-35G2Q
5962-9461107HMC	54230	WS512K32-35G2Q
5962-9461107HMA	88379	ACT-S512K32N-035F2Q
5962-9461107HMC	88379	ACT-S512K32N-035F2Q
5962-9461107HTA	0EU86	AS8S512K32P-35L/Q
5962-9461107HTC	0EU86	AS8S512K32P-35L/Q
5962-9461107HTA	54230	WS512K32N-35H1Q
5962-9461107HTC	54230	WS512K32N-35H1Q
5962-9461107HTA	88379	ACT-S512K32N-035P7Q
5962-9461107HTC	88379	ACT-S512K32N-035P7Q
5962-9461107HXA	<u>3/</u>	WS512K32N-35H2Q
5962-9461107HXC	<u>3/</u>	WS512K32N-35H2Q
5962-9461107HXA	88379	ACT-S512K32N-035P1Q
5962-9461107HXC	88379	ACT-S512K32N-035P1Q
5962-9461107HYA	88379	ACT-S512K32N-035F1Q
5962-9461107HYC	88379	ACT-S512K32N-035F1Q
5962-9461107HYC	54230	WS512K32-35G4TQ
5962-9461107H9A	54230	WS512K32-35G1UQ
5962-9461107H9C	54230	WS512K32-35G1UQ
5962-9461107H9A	88379	ACT-S512K32N-035F18Q
5962-9461107H9C	88379	ACT-S512K32N-035F18Q
5962-9461107HBA	54230	WS512K32-35G1TQ
5962-9461107HBC	54230	WS512K32-35G1TQ
5962-9461108HAA	0EU86	AS8S512K32Q1-25L/883C
5962-9461108HAC	0EU86	AS8S512K32Q1-25L/883C
5962-9461108HAA	54230	WS512K32-25G2LQ
5962-9461108HAC	54230	WS512K32-25G2LQ
5962-9461108HMA	0EU86	AS8S512K32Q-25L/Q
5962-9461108HMC	0EU86	AS8S512K32Q-25L/Q
5962-9461108HMA	54230	WS512K32-25G2Q
5962-9461108HMC	54230	WS512K32-25G2Q
5962-9461108HMA	88379	ACT-S512K32N-025F2Q
5962-9461108HMC	88379	ACT-S512K32N-025F2Q
5962-9461108HTA	0EU86	AS8S512K32P-25L/Q
5962-9461108HTC	0EU86	AS8S512K32P-25L/Q
5962-9461108HTA	54230	WS512K32N-25H1Q
5962-9461108HTC	54230	WS512K32N-25H1Q
5962-9461108HTA	88379	ACT-S512K32N-025P7Q
5962-9461108HTC	88379	ACT-S512K32N-025P7Q
5962-9461108HXA	<u>3/</u>	WS512K32N-25H2Q
5962-9461108HXC	<u>3/</u>	WS512K32N-25H2Q
5962-9461108HXA	88379	ACT-S512K32N-025P1Q
5962-9461108HXC	88379	ACT-S512K32N-025P1Q
5962-9461108HYA	88379	ACT-S512K32N-025F1Q
5962-9461108HYC	88379	ACT-S512K32N-025F1Q
5962-9461108HYC	54230	WS512K32-25G4TQ
5962-9461108H9A	54230	WS512K32-25G1UQ
5962-9461108H9C	54230	WS512K32-25G1UQ
5962-9461108H9A	88379	ACT-S512K32N-025F18Q
5962-9461108H9C	88379	ACT-S512K32N-025F18Q
5962-9461108HBA	54230	WS512K32-25G1TQ
5962-9461108HBC	54230	WS512K32-25G1TQ

See footnotes at end of table.

STANDARD MICROCIRCUIT DRAWING BULLETIN - Continued.

DATE: 04-05-03

Standard microcircuit drawing PIN <u>1/</u>	Vendor CAGE number	Vendor similar PIN <u>2/</u>
5962-9461109HAA	0EU86	AS8S512K32Q1-20L/883C
5962-9461109HAC	0EU86	AS8S512K32Q1-20L/883C
5962-9461109HAA	54230	WS512K32-20G2LQ
5962-9461109HAC	54230	WS512K32-20G2LQ
5962-9461109HMA	0EU86	AS8S512K32Q-20L/Q
5962-9461109HMC	0EU86	AS8S512K32Q-20L/Q
5962-9461109HMA	54230	WS512K32-20G2Q
5962-9461109HMC	54230	WS512K32-20G2Q
5962-9461109HMA	88379	ACT-S512K32N-020F2Q
5962-9461109HMC	88379	ACT-S512K32N-020F2Q
5962-9461109HTA	0EU86	AS8S512K32P-20L/Q
5962-9461109HTC	0EU86	AS8S512K32P-20L/Q
5962-9461109HTA	54230	WS512K32N-20H1Q
5962-9461109HTC	54230	WS512K32N-20H1Q
5962-9461109HTA	88379	ACT-S512K32N-020P7Q
5962-9461109HTC	88379	ACT-S512K32N-020P7Q
5962-9461109HXA	<u>3/</u>	WS512K32N-20H2Q
5962-9461109HXC	<u>3/</u>	WS512K32N-20H2Q
5962-9461109HXA	88379	ACT-S512K32N-020P1Q
5962-9461109HXC	88379	ACT-S512K32N-020P1Q
5962-9461109HYA	88379	ACT-S512K32N-020F1Q
5962-9461109HYC	88379	ACT-S512K32N-020F1Q
5962-9461109HYC	54230	WS512K32-20G4TQ
5962-9461109H9A	54230	WS512K32-20G1UQ
5962-9461109H9C	54230	WS512K32-20G1UQ
5962-9461109H9A	88379	ACT-S512K32N-020F18Q
5962-9461109H9C	88379	ACT-S512K32N-020F18Q
5962-9461109HBA	54230	WS512K32-20G1TQ
5962-9461109HBC	54230	WS512K32-20G1TQ
5962-9461110HAA	0EU86	AS8S512K32Q1-17L/883C
5962-9461110HAC	0EU86	AS8S512K32Q1-17L/883C
5962-9461110HAA	54230	WS512K32-17G2LQ
5962-9461110HAC	54230	WS512K32-17G2LQ
5962-9461110HMA	0EU86	AS8S512K32Q-17L/Q
5962-9461110HMC	0EU86	AS8S512K32Q-17L/Q
5962-9461110HMA	54230	WS512K32-17G2Q
5962-9461110HMC	54230	WS512K32-17G2Q
5962-9461110HMA	88379	ACT-S512K32N-017F2Q
5962-9461110HMC	88379	ACT-S512K32N-017F2Q
5962-9461110HTA	0EU86	AS8S512K32P-17L/Q
5962-9461110HTC	0EU86	AS8S512K32P-17L/Q
5962-9461110HTA	54230	WS512K32N-17H1Q
5962-9461110HTC	54230	WS512K32N-17H1Q
5962-9461110HTA	88379	ACT-S512K32N-017P7Q
5962-9461110HTC	88379	ACT-S512K32N-017P7Q
5962-9461110HXA	<u>3/</u>	WS512K32N-17H2Q
5962-9461110HXC	<u>3/</u>	WS512K32N-17H2Q
5962-9461110HXA	88379	ACT-S512K32N-017P1Q
5962-9461110HXC	88379	ACT-S512K32N-017P1Q
5962-9461110HYA	88379	ACT-S512K32N-017F1Q
5962-9461110HYC	88379	ACT-S512K32N-017F1Q
5962-9461110HYC	54230	WS512K32-17G4TQ
5962-9461110H9A	54230	WS512K32-17G1UQ
5962-9461110H9C	54230	WS512K32-17G1UQ
5962-9461110H9A	88379	ACT-S512K32N-017F18Q
5962-9461110H9C	88379	ACT-S512K32N-017F18Q
5962-9461110HBA	54230	WS512K32-17G1TQ
5962-9461110HBC	54230	WS512K32-17G1TQ

See footnotes at end of table.

STANDARD MICROCIRCUIT DRAWING BULLETIN - Continued.

DATE: 04-05-03

Standard microcircuit drawing PIN 1/	Vendor CAGE number	Vendor similar PIN 2/
5962-9461111HAA	0EU86	AS8S512K32Q1-55/883C
5962-9461111HAC	0EU86	AS8S512K32Q1-55/883C
5962-9461111HAA	54230	WS512K32D-55G2LQ
5962-9461111HAC	54230	WS512K32D-55G2LQ
5962-9461111HMA	0EU86	AS8S512K32Q-55/Q
5962-9461111HMC	0EU86	AS8S512K32Q-55/Q
5962-9461111HMA	54230	WS512K32D-55G2Q
5962-9461111HMC	54230	WS512K32D-55G2Q
5962-9461111HTA	0EU86	AS8S512K32P-55/Q
5962-9461111HTC	0EU86	AS8S512K32P-55/Q
5962-9461111HTA	54230	WS512K32ND-55H1Q
5962-9461111HTC	54230	WS512K32ND-55H1Q
5962-9461111HTA	88379	ACT-S512K32D-055P7Q
5962-9461111HTC	88379	ACT-S512K32D-055P7Q
5962-9461111HXA	3/	WS512K32ND-55H2Q
5962-9461111HXC	3/	WS512K32ND-55H2Q
5962-9461111HYC	54230	WS512K32D-55G4TQ
5962-9461111H9A	54230	WS512K32D-55G1UQ
5962-9461111H9C	54230	WS512K32D-55G1UQ
5962-9461111H9A	88379	ACT-S512K32D-055F18Q
5962-9461111H9C	88379	ACT-S512K32D-055F18Q
5962-9461111HBA	54230	WS512K32D-55G1TQ
5962-9461111HBC	54230	WS512K32D-55G1TQ
5962-9461112HAA	0EU86	AS8S512K32Q1-45/883C
5962-9461112HAC	0EU86	AS8S512K32Q1-45/883C
5962-9461112HAA	54230	WS512K32D-45G2LQ
5962-9461112HAC	54230	WS512K32D-45G2LQ
5962-9461112HMA	0EU86	AS8S512K32Q-45/Q
5962-9461112HMC	0EU86	AS8S512K32Q-45/Q
5962-9461112HMA	54230	WS512K32D-45G2Q
5962-9461112HMC	54230	WS512K32D-45G2Q
5962-9461112HTA	0EU86	AS8S512K32P-45/Q
5962-9461112HTC	0EU86	AS8S512K32P-45/Q
5962-9461112HTA	54230	WS512K32ND-45H1Q
5962-9461112HTC	54230	WS512K32ND-45H1Q
5962-9461112HTA	88379	ACT-S512K32D-045P7Q
5962-9461112HTC	88379	ACT-S512K32D-045P7Q
5962-9461112HXA	3/	WS512K32ND-45H2Q
5962-9461112HXC	3/	WS512K32ND-45H2Q
5962-9461112HYC	54230	WS512K32D-45G4TQ
5962-9461112H9A	54230	WS512K32D-45G1UQ
5962-9461112H9C	54230	WS512K32D-45G1UQ
5962-9461112H9A	88379	ACT-S512K32D-045F18Q
5962-9461112H9C	88379	ACT-S512K32D-045F18Q
5962-9461112HBA	54230	WS512K32D-45G1TQ
5962-9461112HBC	54230	WS512K32D-45G1TQ

See footnotes at end of table.

STANDARD MICROCIRCUIT DRAWING BULLETIN - Continued.

DATE: 04-05-03

Standard microcircuit drawing PIN 1/	Vendor CAGE number	Vendor similar PIN 2/
5962-9461113HAA	0EU86	AS8S512K32Q1-35/883C
5962-9461113HAC	0EU86	AS8S512K32Q1-35/883C
5962-9461113HAA	54230	WS512K32D-35G2LQ
5962-9461113HAC	54230	WS512K32D-35G2LQ
5962-9461113HMA	0EU86	AS8S512K32Q-35/Q
5962-9461113HMC	0EU86	AS8S512K32Q-35/Q
5962-9461113HMA	54230	WS512K32D-35G2Q
5962-9461113HMC	54230	WS512K32D-35G2Q
5962-9461113HTA	0EU86	AS8S512K32P-35/Q
5962-9461113HTC	0EU86	AS8S512K32P-35/Q
5962-9461113HTA	54230	WS512K32ND-35H1Q
5962-9461113HTC	54230	WS512K32ND-35H1Q
5962-9461113HTA	88379	ACT-S512K32D-035P7Q
5962-9461113HTC	88379	ACT-S512K32D-035P7Q
5962-9461113HXA	3/	WS512K32ND-35H2Q
5962-9461113HXC	3/	WS512K32ND-35H2Q
5962-9461113HYC	54230	WS512K32D-35G4TQ
5962-9461113H9A	54230	WS512K32D-35G1UQ
5962-9461113H9C	54230	WS512K32D-35G1UQ
5962-9461113H9A	88379	ACT-S512K32D-035F18Q
5962-9461113H9C	88379	ACT-S512K32D-035F18Q
5962-9461113HBA	54230	WS512K32D-35G1TQ
5962-9461113HBC	54230	WS512K32D-35G1TQ
5962-9461114HAA	0EU86	AS8S512K32Q1-25/883C
5962-9461114HAC	0EU86	AS8S512K32Q1-25/883C
5962-9461114HAA	54230	WS512K32D-25G2LQ
5962-9461114HAC	54230	WS512K32D-25G2LQ
5962-9461114HMA	0EU86	AS8S512K32Q-25/Q
5962-9461114HMC	0EU86	AS8S512K32Q-25/Q
5962-9461114HMA	54230	WS512K32D-25G2Q
5962-9461114HMC	54230	WS512K32D-25G2Q
5962-9461114HTA	0EU86	AS8S512K32P-25/Q
5962-9461114HTC	0EU86	AS8S512K32P-25/Q
5962-9461114HTA	54230	WS512K32ND-25H1Q
5962-9461114HTC	54230	WS512K32ND-25H1Q
5962-9461114HTA	88379	ACT-S512K32D-055P7Q
5962-9461114HTC	88379	ACT-S512K32D-055P7Q
5962-9461114HXA	3/	WS512K32ND-25H2Q
5962-9461114HXC	3/	WS512K32ND-25H2Q
5962-9461114HYC	54230	WS512K32D-25G4TQ
5962-9461114H9A	54230	WS512K32D-25G1UQ
5962-9461114H9C	54230	WS512K32D-25G1UQ
5962-9461114H9A	88379	ACT-S512K32D-025F18Q
5962-9461114H9C	88379	ACT-S512K32D-025F18Q
5962-9461114HBA	54230	WS512K32D-25G1TQ
5962-9461114HBC	54230	WS512K32D-25G1TQ

See footnotes at end of table.

STANDARD MICROCIRCUIT DRAWING BULLETIN - Continued.

DATE: 04-05-03

Standard microcircuit drawing PIN 1/	Vendor CAGE number	Vendor similar PIN 2/
5962-9461115HAA	0EU86	AS8S512K32Q1-20/883C
5962-9461115HAC	0EU86	AS8S512K32Q1-20/883C
5962-9461115HAA	54230	WS512K32D-20G2LQ
5962-9461115HAC	54230	WS512K32D-20G2LQ
5962-9461115HMA	0EU86	AS8S512K32Q-20/Q
5962-9461115HMC	0EU86	AS8S512K32Q-20/Q
5962-9461115HMA	54230	WS512K32D-20G2Q
5962-9461115HMC	54230	WS512K32D-20G2Q
5962-9461115HTA	0EU86	AS8S512K32P-20/Q
5962-9461115HTC	0EU86	AS8S512K32P-20/Q
5962-9461115HTA	54230	WS512K32ND-20H1Q
5962-9461115HTC	54230	WS512K32ND-20H1Q
5962-9461115HTA	88379	ACT-S512K32D-055P7Q
5962-9461115HTC	88379	ACT-S512K32D-055P7Q
5962-9461115HXA	3/	WS512K32ND-20H2Q
5962-9461115HXC	3/	WS512K32ND-20H2Q
5962-9461115HYC	54230	WS512K32D-20G4TQ
5962-9461115H9A	54230	WS512K32D-20G1UQ
5962-9461115H9C	54230	WS512K32D-20G1UQ
5962-9461115H9A	88379	ACT-S512K32D-020F18Q
5962-9461115H9C	88379	ACT-S512K32D-020F18Q
5962-9461115HBA	54230	WS512K32D-20G1TQ
5962-9461115HBC	54230	WS512K32D-20G1TQ
5962-9461116HAA	0EU86	AS8S512K32Q1-17/883C
5962-9461116HAC	0EU86	AS8S512K32Q1-17/883C
5962-9461116HAA	54230	WS512K32D-17G2LQ
5962-9461116HAC	54230	WS512K32D-17G2LQ
5962-9461116HMA	0EU86	AS8S512K32Q-17/Q
5962-9461116HMC	0EU86	AS8S512K32Q-17/Q
5962-9461116HMA	54230	WS512K32D-17G2Q
5962-9461116HMC	54230	WS512K32D-17G2Q
5962-9461116HTA	0EU86	AS8S512K32P-17/Q
5962-9461116HTC	0EU86	AS8S512K32P-17/Q
5962-9461116HTA	54230	WS512K32ND-17H1Q
5962-9461116HTC	54230	WS512K32ND-17H1Q
5962-9461116HTA	88379	ACT-S512K32D-055P7Q
5962-9461116HTC	88379	ACT-S512K32D-055P7Q
5962-9461116HXA	3/	WS512K32ND-17H2Q
5962-9461116HXC	3/	WS512K32ND-17H2Q
5962-9461116HYC	54230	WS512K32D-17G4TQ
5962-9461116H9A	54230	WS512K32D-17G1UQ
5962-9461116H9C	54230	WS512K32D-17G1UQ
5962-9461116H9A	88379	ACT-S512K32D-017F18Q
5962-9461116H9C	88379	ACT-S512K32D-017F18Q
5962-9461116HBA	54230	WS512K32D-17G1TQ
5962-9461116HBC	54230	WS512K32D-17G1TQ
5962-9461117HAA	0EU86	AS8S512K32Q1-15/883C
5962-9461117HAC	0EU86	AS8S512K32Q1-15/883C
5962-9461117HAA	54230	WS512K32D-15G2LQ
5962-9461117HAC	54230	WS512K32D-15G2LQ
5962-9461117HMA	0EU86	AS8S512K32Q-15/Q
5962-9461117HMA	54230	WS512K32D-15G2Q
5962-9461117HMC	0EU86	AS8S512K32Q-15/Q
5962-9461117HMC	54230	WS512K32D-15G2Q
5962-9461117HTA	0EU86	AS8S512K32P-15/Q
5962-9461117HTA	54230	WS512K32ND-15H1Q
5962-9461117HTC	0EU86	AS8S512K32P-15/Q
5962-9461117HTC	54230	WS512K32ND-15H1Q
5962-9461117H9A	54230	WS512K32D-15G1UQ
5962-9461117H9C	54230	WS512K32D-15G1UQ
5962-9461117HBA	54230	WS512K32D-15G1TQ
5962-9461117HBC	54230	WS512K32D-15G1TQ

See footnotes at end of table.

DATE: 04-05-03

Standard microcircuit drawing PIN <u>1/</u>	Vendor CAGE number	Vendor similar PIN <u>2/</u>
5962-9461118HAA	0EU86	AS8S512K32Q1-12/883C
5962-9461118HAC	0EU86	AS8S512K32Q1-12/883C
5962-9461118HAA	54230	WS512K32D-12G2LQ
5962-9461118HAC	54230	WS512K32D-12G2LQ
5962-9461118HMA	0EU86	AS8S512K32Q-12/Q
5962-9461118HMA	54230	WS512K32D-12G2Q
5962-9461118HMC	0EU86	AS8S512K32Q-12/Q
5962-9461118HMC	54230	WS512K32D-12G2Q
5962-9461118HTA	0EU86	AS8S512K32P-12/Q
5962-9461118HTA	54230	WS512K32ND-12H1Q
5962-9461118HTC	0EU86	AS8S512K32P-12/Q
5962-9461118HTC	54230	WS512K32ND-12H1Q
5962-9461118H9A	54230	WS512K32D-12G1UQ
5962-9461118H9C	52230	WS512K32D-12G1UQ
5962-9461118HBA	54230	WS512K32D-12G1TQ
5962-9461118HBC	54230	WS512K32D-12G1TQ
5962-9461119HAA	0EU86	AS8S512K32Q1-15L/883C
5962-9461119HAC	0EU86	AS8S512K32Q1-15L/883C
5962-9461119HAA	54230	WS512K32-15G2LQ
5962-9461119HAC	54230	WS512K32-15G2LQ
5962-9461119HMA	0EU86	AS8S512K32Q-15L/Q
5962-9461119HMA	54230	WS512K32-15G2Q
5962-9461119HMC	0EU86	AS8S512K32Q-15L/Q
5962-9461119HMC	54230	WS512K32-15G2Q
5962-9461119HTA	0EU86	AS8S512K32P-15L/Q
5962-9461119HTA	54230	WS512K32N-15H1Q
5962-9461119HTC	0EU86	AS8S512K32P-15L/Q
5962-9461119HTC	54230	WS512K32N-15H1Q
5962-9461119H9A	54230	WS512K32-15G1UQ
5962-9461119H9C	54230	WS512K32-15G1UQ
5962-9461119HBA	54230	WS512K32D-15G1TQ
5962-9461119HBC	54230	WS512K32D-15G1TQ
5962-9461120HAA	0EU86	AS8S512K32Q1-12L/883C
5962-9461120HAC	0EU86	AS8S512K32Q1-12L/883C
5962-9461120HAA	54230	WS512K32-12G2LQ
5962-9461120HAC	54230	WS512K32-12G2LQ
5962-9461120HMA	0EU86	AS8S512K32Q-12L/Q
5962-9461120HMA	54230	WS512K32-12G2Q
5962-9461120HMC	0EU86	AS8S512K32Q-12L/Q
5962-9461120HMC	54230	WS512K32-12G2Q
5962-9461120HTA	0EU86	AS8S512K32P-12L/Q
5962-9461120HTA	54230	WS512K32N-12H1Q
5962-9461120HTC	0EU86	AS8S512K32P-12L/Q
5962-9461120HTC	54230	WS512K32N-12H1Q
5962-9461120H9A	54230	WS512K32-12G1UQ
5962-9461120H9C	54230	WS512K32-12G1UQ
5962-9461120HBA	54230	WS512K32-12G1TQ
5962-9461120HBC	54230	WS512K32-12G1TQ

- 1/ The lead finish shown for each PIN, representing a hermetic package, is the most readily available from the manufacturer listed for that part. If the desired lead finish is not listed contact the Vendor to determine availability.
- 2/ **Caution.** Do not use this number for item acquisition. Items acquired to this number may not satisfy the performance requirements of this drawing.
- 3/ This part is no longer available.

STANDARD MICROCIRCUIT DRAWING BULLETIN - Continued.

DATE: 04-05-03

<u>Vendor CAGE number</u>	<u>Vendor name and address</u>
0EU86	Austin Semiconductor, Incorporated 8701 Cross Park Drive Austin, TX 78754-4566
54230	White Electronic Designs Corporation 3601 East University Drive Phoenix, AZ 85034-7217
88379	Aeroflex Circuit Technology Corporation 35 South Service Road Plainview, NY 11803-4101

The information contained herein is disseminated for convenience only and the Government assumes no liability whatsoever for any inaccuracies in this information bulletin.