

LOADING PATTERN MATING SIDE

f	3	3	3	3	3	3	3	3	3	3
e	7	7	7	7	7	7	7	7	7	7
d	7	7	7	7	7	7	7	7	7	7
c	G	G	G	G	G	G	G	G	G	G
b	7	7	7	7	7	7	7	7	7	7
a	7	7	7	7	7	7	7	7	7	7
z	3	3	3	3	3	3	3	3	3	3
POS	01				05					10

LOADED CONNECTOR ASSEMBLY
(FOR EXAMPLE)

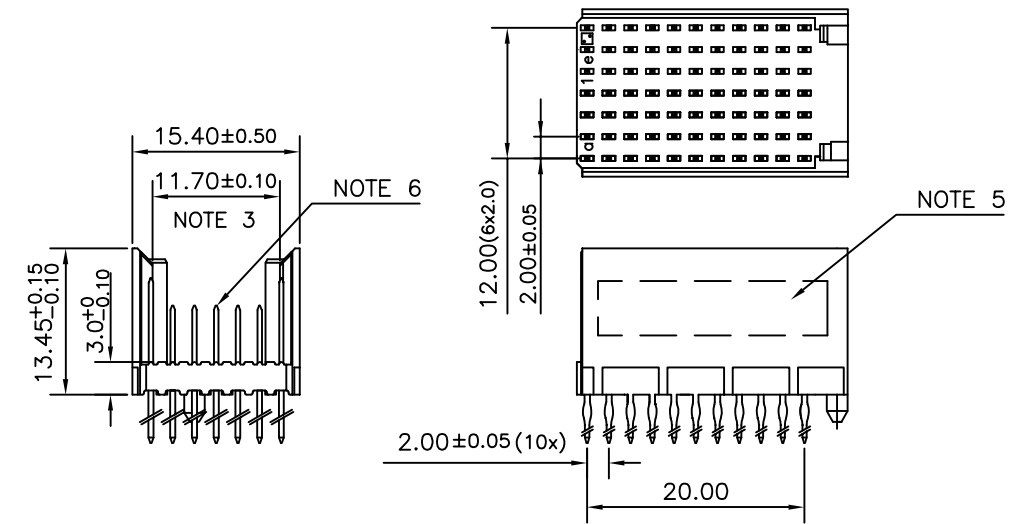

CONTACT OVERVIEW

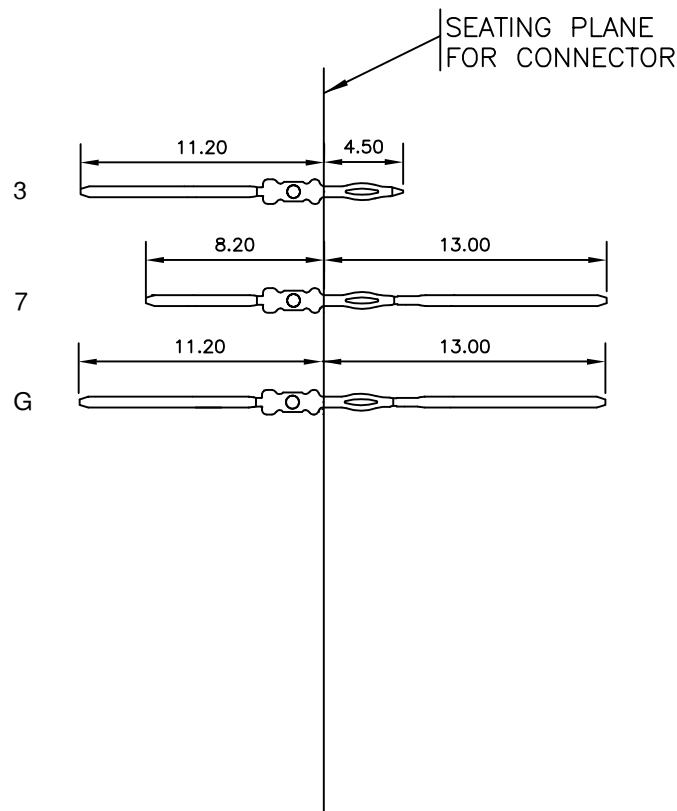

LAY-OUT P.C.B.-HOLE

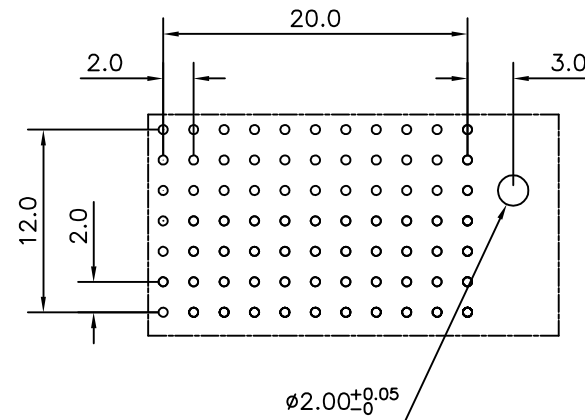

LEAD FREE INDICATOR : LF = LEAD FREE
(DIGIT 15 & 16)

HM2P09PK5151

PLATING CODE (DIGIT 13 AND 14)
(REF DRW NO. BS,C , 201844 , 003)

NOTES

1. THIS PRODUCT IS CSA APPROVED.
2. THIS PRODUCT IS UL RECOGNIZED.
3. MEASURED AT THE BOTTOM.
4. MATERIAL CONTACT: PHOSPHORBRONZE
HOUSING: CREAM WHITE GLASS FILLED POLYESTER UL-94V0
5. CONNECTOR PRINTED WITH P/N AND DATE CODE.
6. FOR ACTUAL CONTACT LOADINGS, SEE LOADING PATTERN MATING SIDE.
7. SHAPE OF CONNECTOR HOUSING CAN ALTER DEPENDING ON PRODUCTION LOCATION
8. THE PRODUCT (LF) MEETS EUROPEAN UNION DIRECTIVES AND OTHER COUNTRY REGULATIONS AS DESCRIBED IN GS-22-008
9. FOR RECOMMENDED PTH DIMENSIONS REFER DRAWING : BS, A , 201572 , 001

CATALOG NO: HM2P09PK5151-----

mat'l. code SEE NOTE 4				surface ISO 1302 ✓		tolerance ISO 406 ISO 1101		projection MM		product family MILLIPACS			
litr				ecn no		dr		date		title			
A				I05-0247		MINI		2005-11-04		MPACS 5+2R STR HDR PF CONN TYPE C			
B				I06-0132		MINI		2006-07-31					
				angles		linear		0°±1°		scale		-	
				dr		MINI K VANDANATH		2005-11-04		dwg no		sheet 1 of 1 size	
				enr		BIJU K PAUL		2005-11-04		FCI		BS, C ,203028,525 A3	
				chr		BIJU K PAUL		2006-07-31		type		Product Customer Drawing	
				appd		BIJU K PAUL		2006-07-31					
sheet index		revision sheet		B		1							