

FEATURES

- PEAK PULSE POWER= 1500 W @ 1ms
- BREAKDOWN VOLTAGE RANGE :
From 6V8 to 220 V
- UNI AND BIDIRECTIONAL TYPES
- LOW CLAMPING FACTOR
- FAST RESPONSE TIME
- UL RECOGNIZED

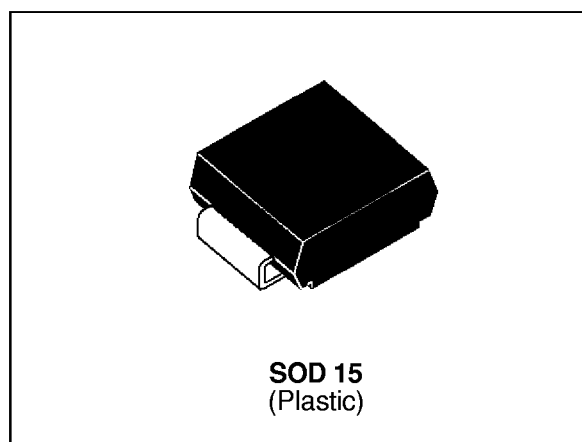

DESCRIPTION

Transil diodes provide high overvoltage protection by clamping action. Their instantaneous response to transients makes them particularly suited to protect voltage sensitive devices such as MOS Technology and low voltage supplied IC's.

ABSOLUTE MAXIMUM RATINGS ($T_{amb} = 25^{\circ}\text{C}$)

Symbol	Parameter		Value	Unit
P_p	Peak pulse power dissipation		1500	W
P	Power dissipation on infinite heatsink	$T_{lead} = 50^{\circ}\text{C}$	5	W
T_{stg} T_j	Storage temperature range Maximum junction temperature		- 65 to + 175 150	$^{\circ}\text{C}$ $^{\circ}\text{C}$
T_L	Maximum lead temperature for soldering during 10 s.		260	$^{\circ}\text{C}$

THERMAL RESISTANCES

Symbol	Parameter	Value	Unit
$R_{th(j-l)}$	Junction to leads on infinite heatsink	20	$^{\circ}\text{C}/\text{W}$
$R_{th(j-a)}$	Junction to ambient on printed circuit. With standard footprint dimensions.	75	$^{\circ}\text{C}/\text{W}$

SM15Txx

ELECTRICAL CHARACTERISTICS

(T_{amb} = 25°C)

Symbol	Parameter
V _{RM}	Stand-off voltage
V _{BR}	Breakdown voltage
V _{CL}	Clamping voltage
I _{RM}	Leakage current @ V _{RM}
I _{PP}	Peak pulse current
αT	Voltage temperature coefficient
V _F	Forward Voltage drop V _F < 3.5V @ I _F = 100 A.

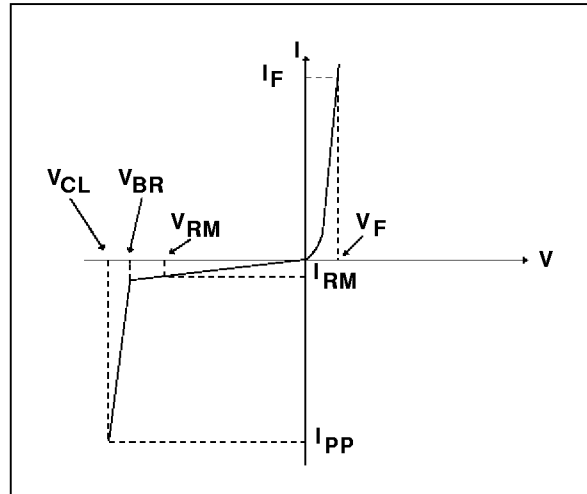

Types				I _{RM} @ V _{RM}		V _{BR} @ I _R				V _{CL} @ I _{PP}		V _{CL} @ I _{PP}		αT	C
				max		min	nom	max		max		max		max	typ
Uni-directional	Mar-king	Bi-directional	Mar-king	μA	V	V	V	V	mA	V	A	V	A	10 ⁻⁴ /°C	note4
SM15T6V8	MDD	SM15T6V8C	BDD	1000	5.8	6.45	6.8	7.48	10	10.5	143	13.4	746	5.7	9500
SM15T6V8A	MDE	SM15T6V8CA	BDE	1000	5.8	6.45	6.8	7.14	10	10.5	143	13.4	746	5.7	9500
SM15T7V5	MDF	SM15T7V5C	BDF	500	6.4	7.13	7.5	8.25	10	11.3	132	14.5	690	6.1	8500
SM15T7V5A	MDG	SM15T7V5CA	BDG	500	6.4	7.13	7.5	7.88	10	11.3	132	14.5	690	6.1	8500
SM15T10	MDN	SM15T10C	BDN	10	8.55	9.5	10	11.0	1	14.5	103	18.6	538	7.3	7000
SM15T10A	MDP	SM15T10CA	NDP	10	8.55	9.5	10	10.5	1	14.5	103	18.6	538	7.3	7000
SM15T12	MDS	SM15T12C	BDS	5	10.2	11.4	12	13.2	1	16.7	90	21.7	461	7.8	6000
SM15T12A	MDT	SM15T12CA	BDT	5	10.2	11.4	12	12.6	1	16.7	90	21.7	461	7.8	6000
SM15T15	MDW	SM15T15C	BDW	5	12.8	14.3	15	16.5	1	21.2	71	27.2	368	8.4	5000
SM15T15A	MDX	SM15T15CA	BDX	5	12.8	14.3	15	15.8	1	21.2	71	27.2	368	8.4	5000
SM15T18	MED	SM15T18C	BED	5	15.3	17.1	18	19.8	1	25.2	59.5	32.5	308	8.8	4300
SM15T18A	MEE	SM15T18CA	BEE	5	15.3	17.1	18	18.9	1	25.2	59.5	32.5	308	8.8	4300
SM15T22	MEH	SM15T22C	BEH	5	18.8	20.9	22	24.2	1	30.6	49	39.3	254	9.2	3700
SM15T22A	MEK	SM15T22CA	BEK	5	18.8	20.9	22	23.1	1	30.6	49	39.3	254	9.2	3700
SM15T24	MEL	SM15T24C	BEL	5	20.5	22.8	24	26.4	1	33.2	45	42.8	234	9.4	3500
SM15T24A	MEM	SM15T24CA	BEM	5	20.5	22.8	24	25.2	1	33.2	45	42.8	234	9.4	3500
SM15T27	MEN	SM15T27C	BEN	5	23.1	25.7	27	29.7	1	37.5	40	48.3	207	9.6	3200
SM15T27A	MEP	SM15T27CA	BEP	5	23.1	25.7	27	28.4	1	37.5	40	48.3	207	9.6	3200
SM15T30	MEQ	SM15T30C	BEQ	5	25.6	28.5	30	33.0	1	41.5	36	53.5	187	9.7	2900
SM15T30A	MER	SM15T30CA	BER	5	25.6	28.5	30	31.5	1	41.5	36	53.5	187	9.7	2900
SM15T33	MES	SM15T33C	BES	5	28.2	31.4	33	36.3	1	45.7	33	59.0	169	9.8	2700
SM15T33A	MET	SM15T33CA	BET	5	28.2	31.4	33	34.7	1	45.7	33	59.0	169	9.8	2700
SM15T36	MEU	SM15T36C	BEU	5	30.8	34.2	36	39.6	1	49.9	30	64.3	156	9.9	2500
SM15T36A	MEV	SM15T36CA	BEV	5	30.8	34.2	36	37.8	1	49.9	30	64.3	156	9.9	2500
SM15T39	MEW	SM15T39C	BEW	5	33.3	37.1	39	42.9	1	53.9	28	69.7	143	10.0	2400
SM15T39A	MEX	SM15T39CA	BEX	5	33.3	37.1	39	41.0	1	53.9	28	69.7	143	10.0	2400
SM15T68	MFN	SM15T68C	BFN	5	58.1	64.6	68	74.8	1	92	16.3	121	83	10.4	1550
SM15T68A	MFP	SM15T68CA	BFP	5	58.1	64.6	68	71.4	1	92	16.3	121	83	10.4	1550
SM15T100	MFW	SM15T100C	BFW	5	85.5	95.0	100	110	1	137	11	178	56	10.6	1150
SM15T100A	MFX	SM15T100CA	BFX	5	85.5	95.0	100	105	1	137	11	178	56	10.6	1150

Types				I _{RM} @ V _{RM}		V _{BR} @ I _R				V _{CL} @ I _{PP}		V _{CL} @ I _{PP}		αT	C
				max		min	nom	max		max		max	max	max	typ
Uni-directional	Mar-king	Bi-directional	Mar-king	μA	V	V	V	V	mA	V	A	V	A	10 ⁻⁴ /°C	note4
SM15T150	MGH	SM15T150C	BGH	5	128	143	150	165	1	207	7.2	265	38	10.8	850
SM15T150A	MGK	SM15T150CA	BGK	5	128	143	150	158	1	207	7.2	265	38	10.8	850
SM15T200	MGU	SM15T200C	BGU	5	171	190	200	220	1	274	5.5	353	28	10.8	675
SM15T200A	MGV	SM15T200CA	BGV	5	171	190	200	210	1	274	5.5	353	28	10.8	675
SM15T220	MGW	SM15T220C	BGW	5	188	209	220	242	1	328	4.6	388	26	10.8	625
SM15T220A	MGX	SM15T220CA	BGX	5	188	209	220	231	1	328	4.6	388	26	10.8	625

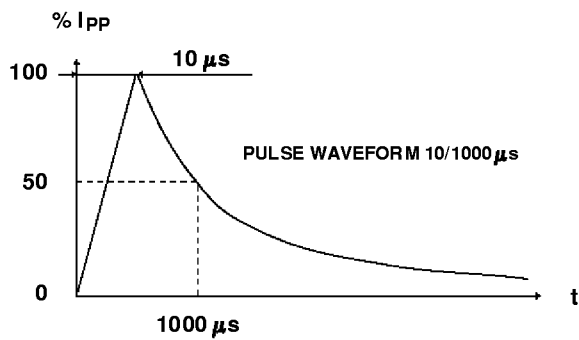
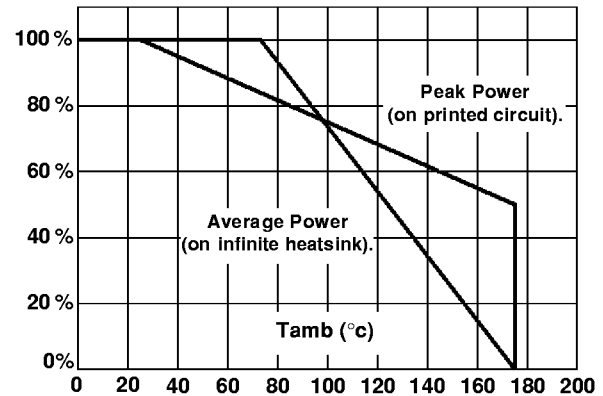

Fig. 1: Power dissipation derating versus ambient temperature



- Note 1 :** For surges greater than the maximum values, the diode will present a short-circuit Anode - Cathode.
- Note 2 :** Pulse test: $t_p < 50$ ms.
- Note 3 :** $\Delta V_{BR} = \alpha T * (T_{amb} - 25) * V_{BR}(25^\circ C)$.
- Note 4 :** $V_R = 0$ V, $F = 1$ MHz. For bidirectional types, capacitance value is divided by 2.

Fig. 2 : Peak pulse power versus exponential pulse duration.

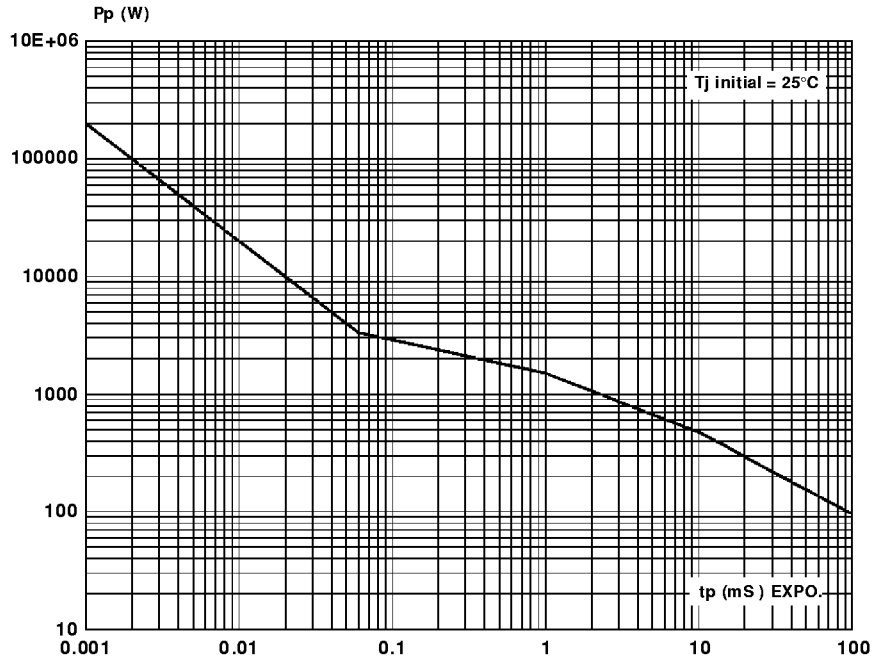
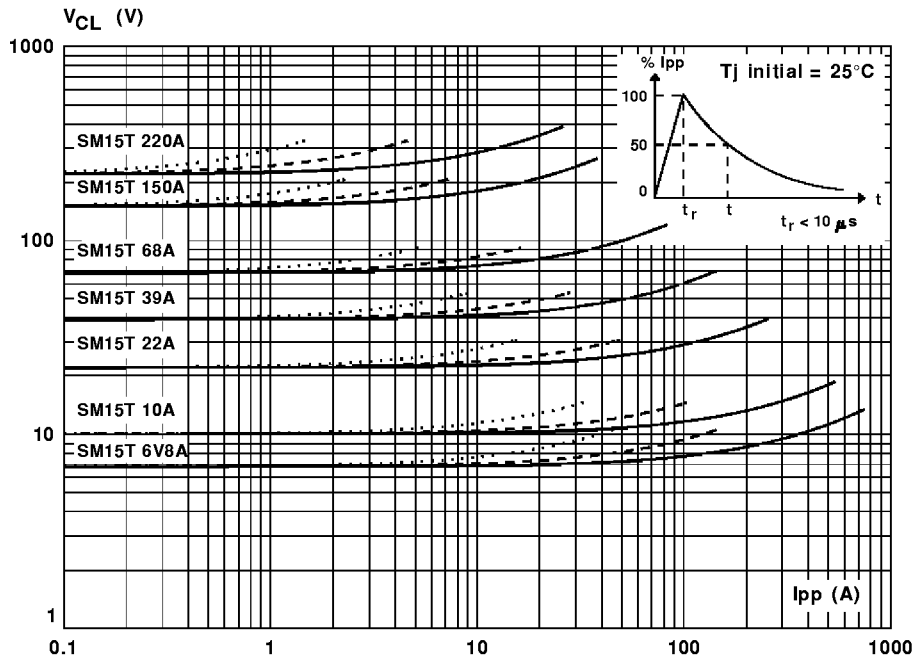

Fig. 3 : Clamping voltage versus peak pulse current.
 Exponential waveform $t_p = 20 \mu s$ _____
 $t_p = 1 ms$ _____
 $t_p = 10 ms$



Note : The curves of the figure 3 are specified for a junction temperature of 25 °C before surge.
 The given results may be extrapolated for other junction temperatures by using the following formula :
 $\Delta V_{BR} = \alpha T \cdot [T_{amb} - 25] \cdot V_{BR}(25^\circ C)$.
 For intermediate voltages, extrapolate the given results.

Fig. 4a : Capacitance versus reverse applied voltage for unidirectional types (typical values)

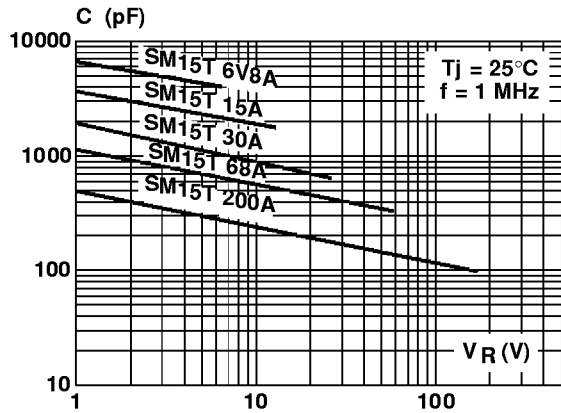

Fig. 4b : Capacitance versus reverse applied voltage for bidirectional types (typical values).

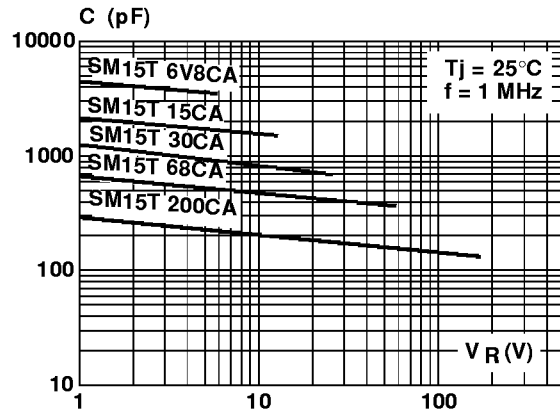

Fig. 5 : Peak forward voltage drop versus peak forward current (typical values for unidirectional types)

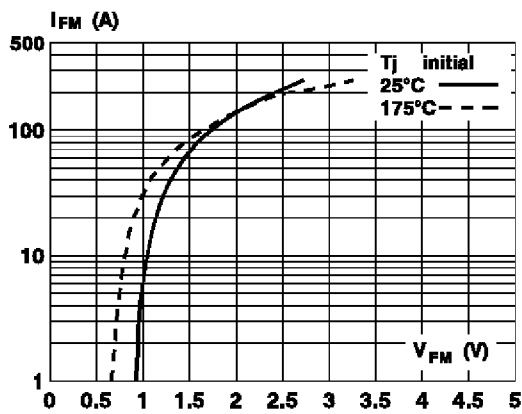
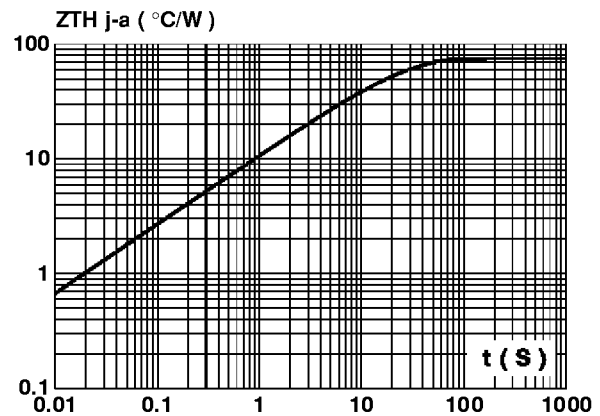
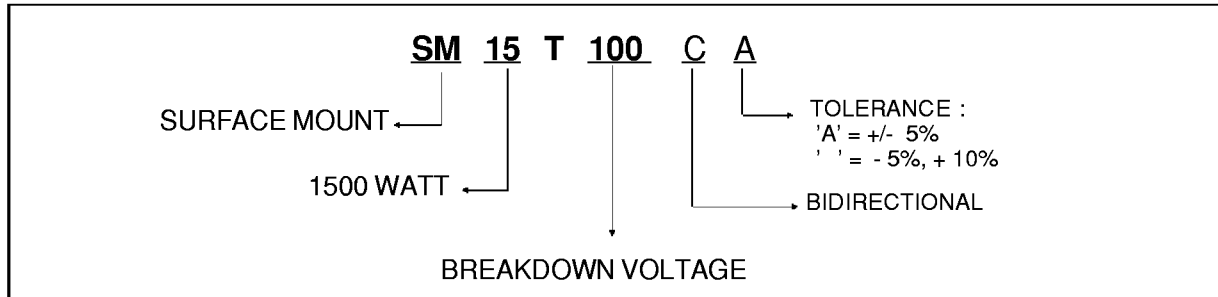

Fig. 6 : Transient thermal impedance junction-ambient versus pulse duration. For a mounting on PC Board with standard footprint dimensions



SM15Txx

ORDER CODE



MARKING : Logo, Date Code, Type Code, Cathode Band (for unidirectional types only).

PACKAGE MECHANICAL DATA

SOD15 (Plastic)

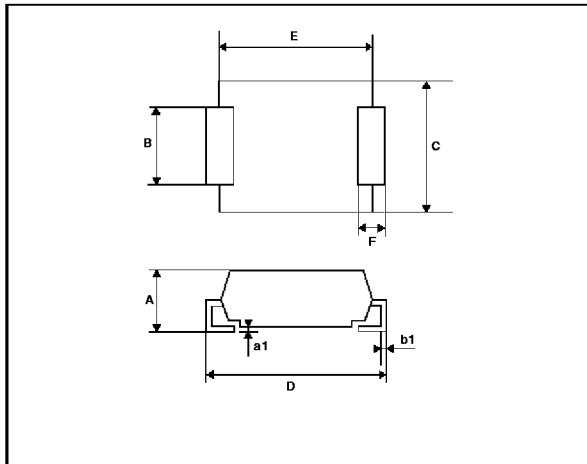

REF.	DIMENSIONS			
	Millimeters		Inches	
	Min.	Max.	Min.	Max.
A	2.50	3.10	0.098	0.122
a1	0.05	0.20	0.002	0.008
B	2.90	3.10	0.114	0.122
b1	0.29	0.32	0.011	0.012
C	4.80	5.20	0.189	0.204
D	7.60	8.00	0.299	0.315
E	6.30	6.60	0.225	0.259
F	1.30	1.70	0.051	0.056

Weight = 0.25 g.

Packaging : standard packaging is in film.

FOOTPRINT DIMENSIONS (Millimeter)

SOD 15 Plastic.

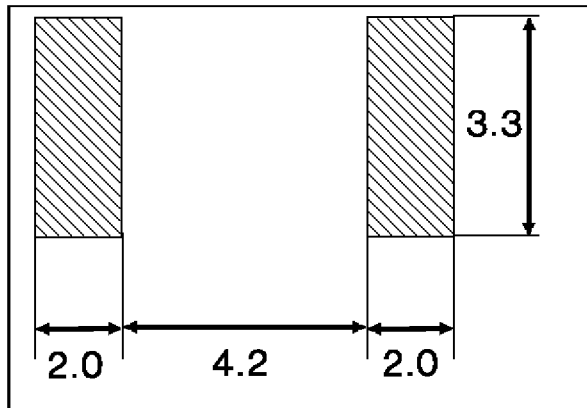

Information furnished is believed to be accurate and reliable. However, SGS-THOMSON Microelectronics assumes no responsibility for the consequences of use of such information nor for any infringement of patents or other rights of third parties which may result from its use. No license is granted by implication or otherwise under any patent or patent rights of SGS-THOMSON Microelectronics. Specifications mentioned in this publication are subject to change without notice. This publication supersedes and replaces all information previously supplied. SGS-THOMSON Microelectronics products are not authorized for use as critical components in life support devices or systems without express written approval of SGS-THOMSON Microelectronics.

© 1995 SGS-THOMSON Microelectronics - Printed in Italy - All rights reserved.

SGS-THOMSON Microelectronics GROUP OF COMPANIES

Australia - Brazil - France - Germany - Hong Kong - Italy - Japan - Korea - Malaysia - Malta - Morocco - The Netherlands - Singapore - Spain - Sweden - Switzerland - Taiwan - Thailand - United Kingdom - U.S.A.