

Material:

- △ * Housing : LCP With 35% GF/mineral.
or Nylon 9T, UL 94V-0 Color Black
- * Contact: Phosphor Bronze
- * Pick & Place Pad: High Temperature Plastic

Ordering Code

CB50 ** 2 0 0 T 0
① ② ③ ④ ⑤ ⑥ ⑦

- Series No.
- Contacts: 04~48
- Plating option :
 - 1= 3.05μm(120μ") Min. Tin plated over 1.27μm(50μ") Nickel
 - 2= 0.05μm(2μ") Min. Gold flash over 1.27μm(50μ") Nickel
 - 3= 0.38μm(15μ") Min. Gold plated over 1.27μm(50μ") Nickel
 - 4= 0.76μm(30μ") Min. Gold plated over 1.27μm(50μ") Nickel
- 0= Without Peg, P= With Peg
- 0= Without Pick & Place Pad, P= With Pick & Place Pad
- Packing: R=Tape & Reel ,T= Tube Packaged
- Other Option: 0=LCP (Standard), M=Nylon 9T

* The one with both Peg and Pad is with Tape & Reel packing only.

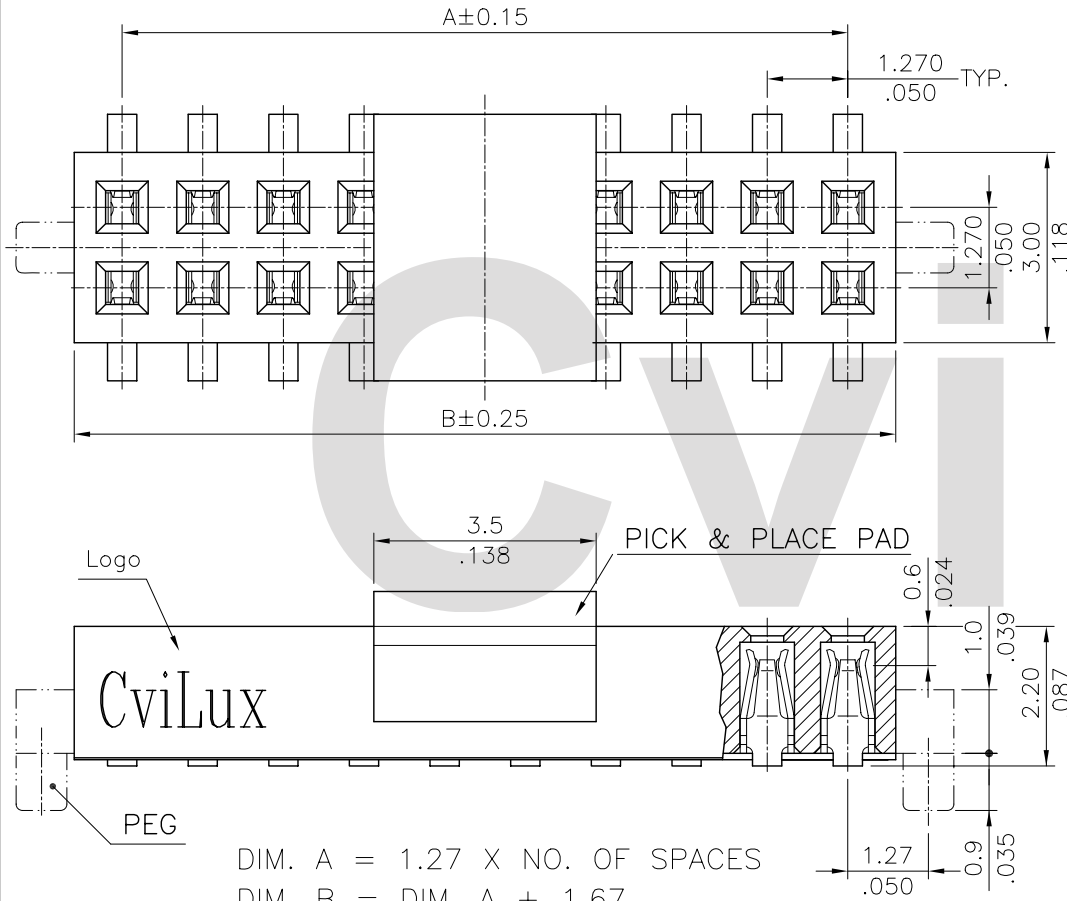

DIM. A = 1.27 X NO. OF SPACES
DIM. B = DIM. A + 1.67

* AVAILABLE IN 4 THROUGH 48 CIRCUITS

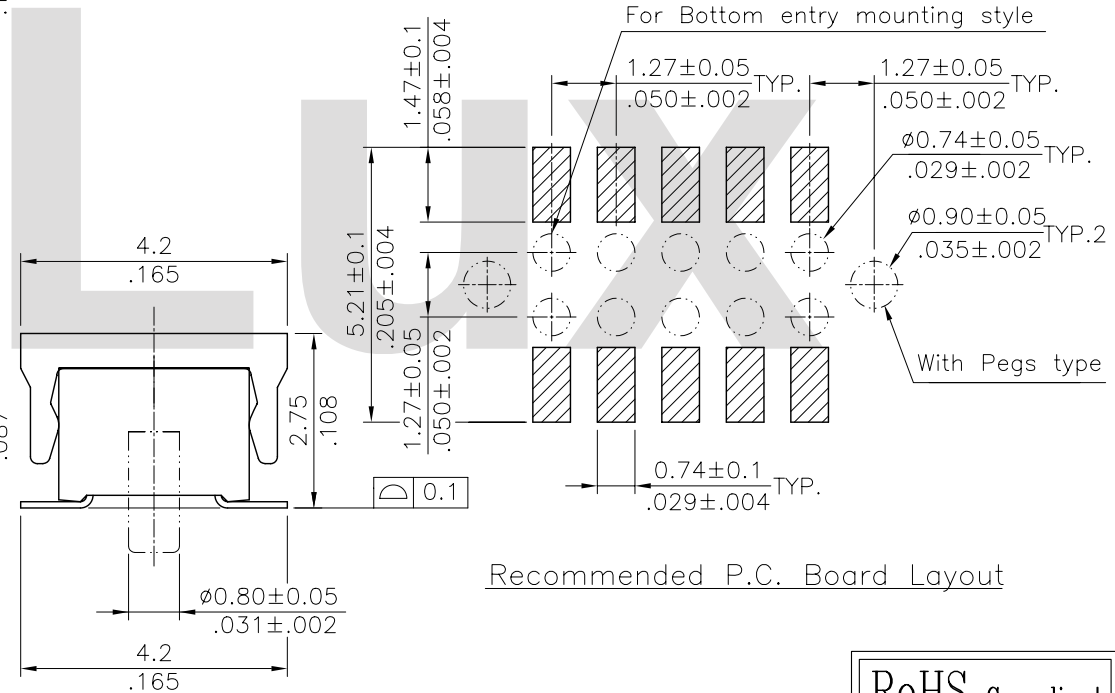

Recommended P.C. Board Layout

RoHS Compliant

| | | | | | | | | |
|-----|-------|----------|---------------------|-------------------|----------|--------------------------------------|--|--|
| △9 | Karen | 9/21-09' | ECN09465 | | DATE | UNIT: mm / inch | TITLE: LOW PROFILE 1.27*1.27MM SMT TYPE SOCKET |  瀚荃股份有限公司 CviLux Corporation |
| △8 | Sun | 9/30-08' | ECN08113-1/ECN08475 | DRAWN BY: Karen | 9/21-09' | TOLERANCE UNLESS OTHERWISE SPECIFIED | MATERIAL: | |
| △7 | Sandy | 5/28-07' | ECN07188/ECR07023-1 | ENGINEER: Eisley | 9/23-09' | .X ± 0.25/.010 X: ± 1' | FINISH: | |
| △6 | Sandy | 4/29-07' | ECN07153 | CHECKED BY: David | 9/23-09' | .XX ± 0.15/.006 .X' ± | | |
| SYM | NAME | DATE | REVISIONS | APPROVED BY: Alex | 9/23-09' | .XXX ± 0.08/.003 .XX' ± | | DRAWING NO. CB5001SL PART NO. CB50***** SCALE 8 / 1 SHEET 1 OF 2 |

CVILUX CORP
2009.09.29
ISSUED

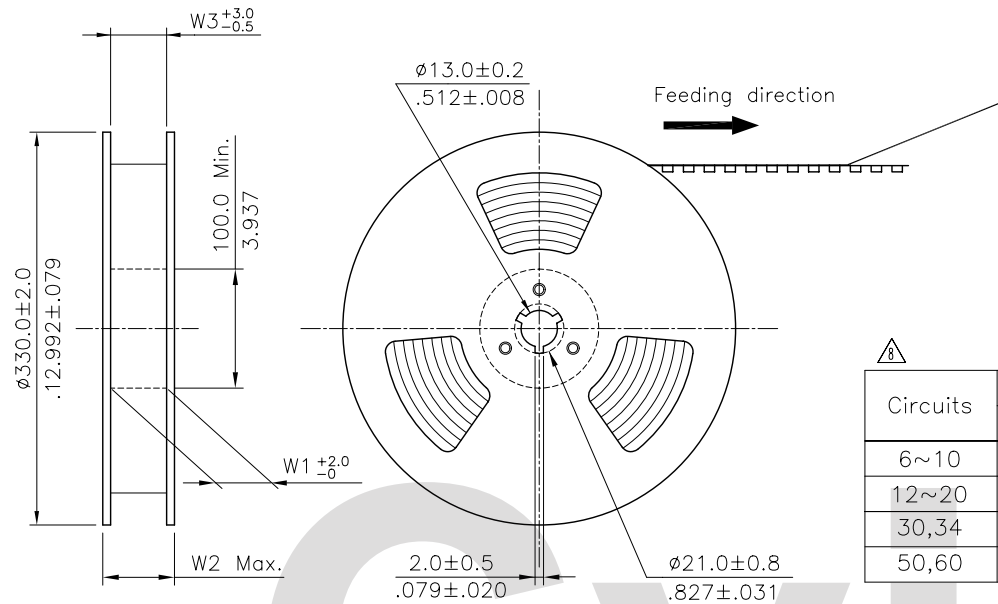

NOTE :

- * Reel Material : HIPS
- * Carrier Material : Transparent Conductive Polystyrene Alloy
- * Cover Tape Material : Polyester
- * Cover Tape Peel Strength : 0.1N – 1.3N
- * Carrier camber is within 1mm in 250mm
- * All dimensions meet EIA-481-B requirements.
- * Quantity : 2000 PCS/Reel

| Circuits | Dimension | | | | | Packing (Reel/Caton) |
|----------|--------------|--------------|-------------|-------------|-------------|----------------------|
| | E | F | W1 | W2 | W3 | |
| 6~10 | 16.00(.630) | 7.50(.295) | 16.5(.650) | 22.5(.886) | 16.5(.650) | 11 |
| 12~20 | 24.00(.945) | 11.50(.453) | 24.5(.965) | 30.5(1.201) | 24.5(.965) | 9 |
| 30,34 | 44.00(1.732) | 40.40(1.596) | 44.5(1.752) | 50.5(1.988) | 44.5(1.752) | 5 |
| 50,60 | 56.00(2.205) | 52.40(2.062) | 56.5(2.224) | 62.5(2.460) | 56.5(2.224) | 3 |

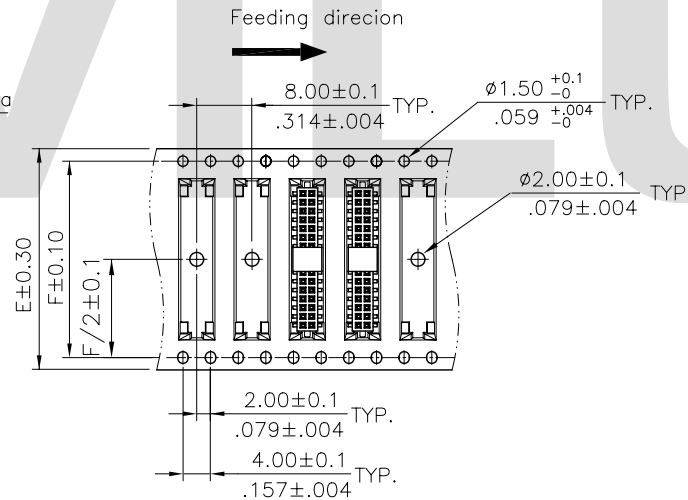
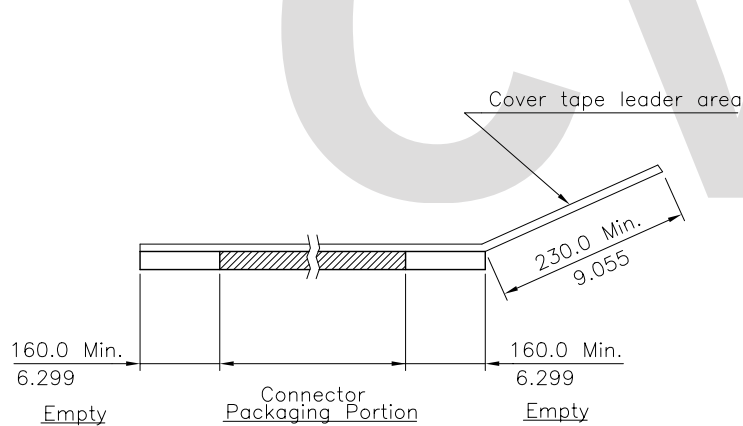

WIDTH : 32.44 mm Carrier

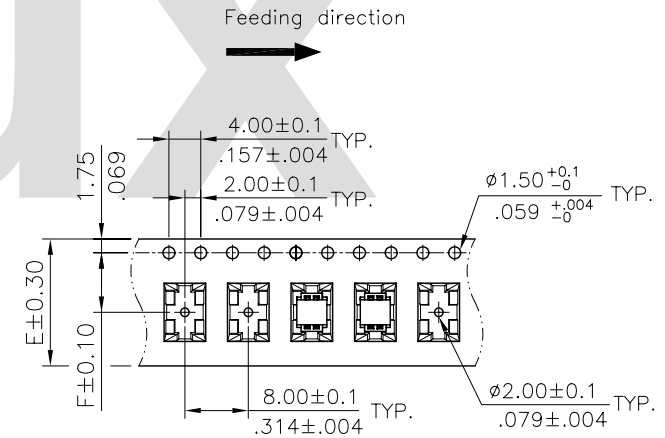

WIDTH : 16.24 mm Carrier

RoHS Compliant

| | | | | | | | | |
|-----|-------|----------|---------------------|-------------------|----------|--------------------------------------|--|---|
| 9 | Karen | 9/21-09' | ECN09465 | | DATE | UNIT: mm / inch | TITLE: LOW PROFILE 1.27*1.27MM SMT TYPE SOCKET | 瀚荃股份有限公司 CviLux Corporation |
| 8 | Sun | 9/30-08' | ECN08113-1/ECN08475 | DRAWN BY: Karen | 9/21-09' | TOLERANCE UNLESS OTHERWISE SPECIFIED | MATERIAL: | |
| 7 | Sandy | 5/28-07' | ECN07188/ECR07023-1 | ENGINEER: Sandy | 9/23-09' | .X ± X' ± 1' | FINISH: | DRAWING NO. CB5001SL PART NO. CB50***** |
| 6 | Sandy | 4/29-07' | ECN07153 | CHECKED BY: David | 9/23-09' | .XX ± .X' ± | | SCALE |
| SYM | NAME | DATE | REVISIONS | APPROVED BY: Alex | 9/23-09' | .XXX ± .XX' ± | | |

