



TS9011/TS9011A

250mA CMOS Low Dropout Voltage Regulator

TO-92



SOT-23



Pin assignment

TO-92

1. Gnd
2. Input
3. Output

SOT-23

1. Gnd
2. Out
3. Input

SOT-89



Pin assignment

SOT-89

1. Gnd
2. Input
3. Output

TS9011A

1. Output
2. Gnd
3. Input

Low Power Consumption 2uA
Low Drop Out Voltage 0.4V

General Description

The TS9011/A series is a positive voltage regulator developed utilizing CMOS technology featured very low power consumption, low dropout voltage and high output voltage accuracy. Built in low on-resistor provides low dropout voltage and large output current. A 1uF or greater can be used as an output capacitor.

The TS9011/A series are prevented device failure under the worst operation condition with both thermal shutdown and current fold-back. These series are recommended for configuring portable devices and large current application, respectively.

This series are offered in 3-pin TO-92, SOT-89 and SOT-23 package.

Features

- ✧ Dropout voltage typically 0.38V @Io=200mA (Vo=5V)
- ✧ Output current up to 250mA
- ✧ Low power consumption, 2uA(typ) @Vo=5V
- ✧ Output voltage +/-2%
- ✧ Internal current limit
- ✧ Thermal shutdown protection

Applications

- ✧ Palmtops
- ✧ Video recorders
- ✧ Battery powered equipment
- ✧ PC peripherals
- ✧ CD-ROM
- ✧ Digital signal camera

Block Diagram

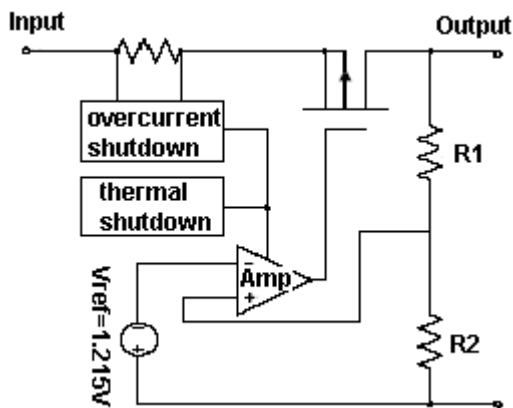

Ordering Information

Part No.	Operating Temp.	Package
TS9011xCT	-20 ~ +85 °C	TO-92
TS9011xCX		SOT-23
TS9011xCY		SOT-89
TS9011AxCY		

Note: Where **x** denotes voltage option, available are A = 1.5V, D=1.8V, K=2.5V, P=3.0V, N=2.8V, S=3.3V, 5=5.0V. Contact factory for additional voltage options.

Typical Application Circuit

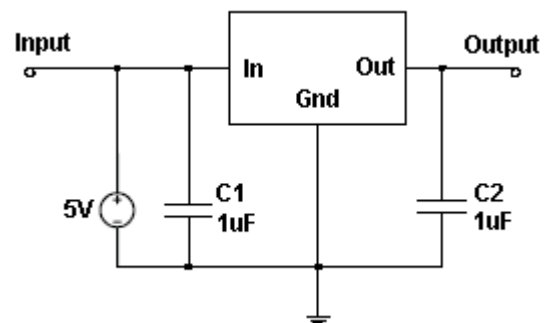



Absolute Maximum Rating				
Input Supply Voltage	Vin(max.)	+12	V	
Input Operating Voltage	Vin(opr.)	+10		
Output Current	Io	$P_D / (V_{in} - V_o)$	V	
Power Dissipation	SOT-23	P _D	W	
	SOT-89			0.30
	TO-92			0.50
Operating Junction Temperature Range	T _J	-40 ~ +150	°C	
Storage Temperature Range	T _{STG}	-65 ~ +150	°C	
Lead Soldering Temperature (260 °C)		10	S	

Caution: Stress above the listed absolute rating may cause permanent damage to the device.

Electrical Characteristics

T_a = 25 °C unless otherwise specified.

Parameter	Conditions	Min	Typ	Max	Unit	
Output Voltage	Vin=Vo + 1V, Io =40mA,	TS9011/A5	4.900	5.0	5.100	V
		TS9011/AS	3.234	3.3	3.366	
		TS9011/AP	2.94	3.0	3.06	
		TS9011/AK	2.450	2.5	2.550	
		TS9011/AD	1.764	1.8	1.836	
		TS9011/AA	1.47	1.5	1.53	
Maximum Output Current	Vin=Vo+1V,	250	--	--	mA	
Input Stability	Vo+1V ≤ Vin ≤ Vo+2V, Io=1mA	--	0.2	0.3	%	
Load Regulation (Note 1)	Vin=Vo+1V, 1mA ≤ I _L ≤ 100mA	TS9011/A5	--	40	80	mV
		TS9011/AS				
	Vin=Vo+1V, 1mA ≤ I _L ≤ 80mA	TS9011/AP	--	40	90	
		TS9011/AK				
		TS9011/AD				
TS9011/AA						
Dropout Voltage (Note 2)	Io=250mA	TS9011/A5	--	400	600	mV
	Io=200mA	TS9011/AS	--	400	650	
	Io=160mA	TS9011/AP	--	400	700	
	Io=160mA	TS9011/AK	--	400	700	
	Io=120mA	TS9011/AD	--	400	750	
	Io=100mA	TS9011/AA	--	850	1000	
Quiescent Current	Vin=Vo+1V, Io=0A	--	2	5	uA	
Output Current Limit	Vout < 0.4V	--	400	--	mA	
Power Supply Rejection Ratio	At f=100KHz, Io=10mA,	--	30	--	dB	
Output Voltage Temperature Coefficient (Note 3)		--	100	--	ppm/°C	

Note: 1. Regulation is measured at constant junction temperature, using pulsed ON time.

2. Dropout is measured at constant junction temperature, using pulsed ON time, and the criterion is Vout inside target value +/-2%.

3. Guaranteed by design.

SOT-89 Mechanical Drawing

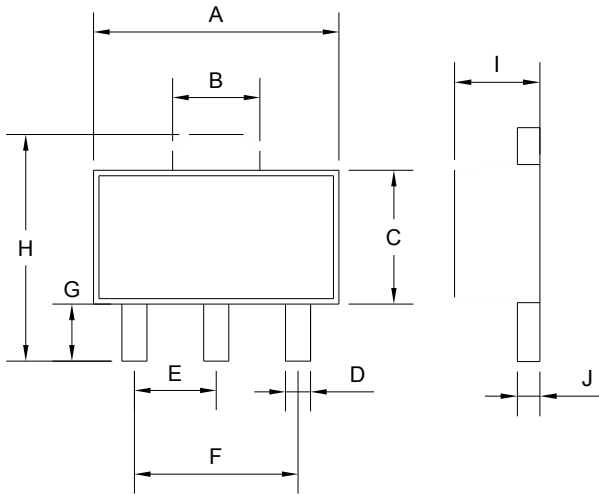

SOT-89 DIMENSION				
DIM	MILLIMETERS		INCHES	
	MIN	MAX	MIN	MAX
A	4.40	4.60	0.173	0.181
B	1.50	1.7	0.059	0.070
C	2.30	2.60	0.090	0.102
D	0.40	0.52	0.016	0.020
E	1.50	1.50	0.059	0.059
F	3.00	3.00	0.118	0.118
G	0.89	1.20	0.035	0.047
H	4.05	4.25	0.159	0.167
I	1.4	1.6	0.055	0.068
J	0.35	0.44	0.014	0.017

SOT-23 Mechanical Drawing

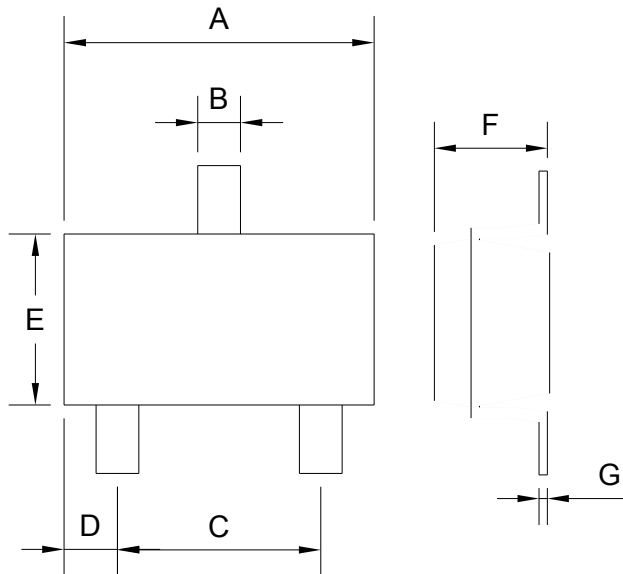

SOT-23 DIMENSION				
DIM	MILLIMETERS		INCHES	
	MIN	MAX	MIN	MAX
A	2.88	2.91	0.113	0.115
B	0.39	0.42	0.015	0.017
C	1.78	2.03	0.070	0.080
D	0.51	0.61	0.020	0.024
E	1.59	1.66	0.063	0.065
F	1.04	1.08	0.041	0.043
G	0.07	0.09	0.003	0.004

TO-92 Mechanical Drawing

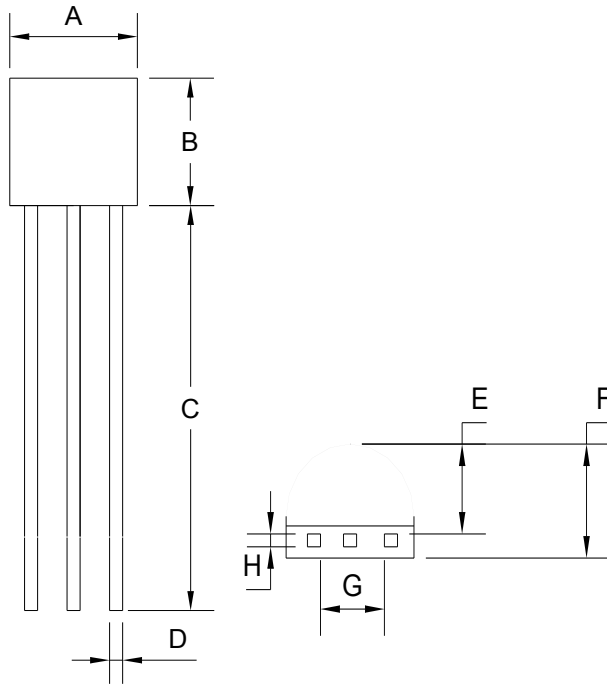

TO-92 DIMENSION				
DIM	MILLIMETERS		INCHES	
	MIN	MAX	MIN	MAX
A	4.30	4.70	0.169	0.185
B	4.30	4.70	0.169	0.185
C	14.30(typ)		0.563(typ)	
D	0.43	0.49	0.017	0.019
E	2.19	2.81	0.086	0.111
F	3.30	3.70	0.130	0.146
G	2.42	2.66	0.095	0.105
H	0.37	0.43	0.015	0.017