

SANKEN

SANKEN
LIGHT EMITTING DIODES

T-1 3/4 Surface Illumination Type SEL 1013 Series (Non-Diffused)

SEL 1213 C SEL 1813 A
SEL 1413 E SEL 1913 K
SEL 1713 K

FEATURES

- Wide Viewing Angle, Suitable for Surface Illumination
- Long-life/High Reliability
- Selection of 5 Colors/Intensities
- Pulse-Drivable
- CMOS/MOS, TTL Compatible

APPLICATIONS

- Display in Areas of 6.5×16 and 10×14
- Panel Backlight, Keyboard Display
- Portable Device
- Audio Equipment

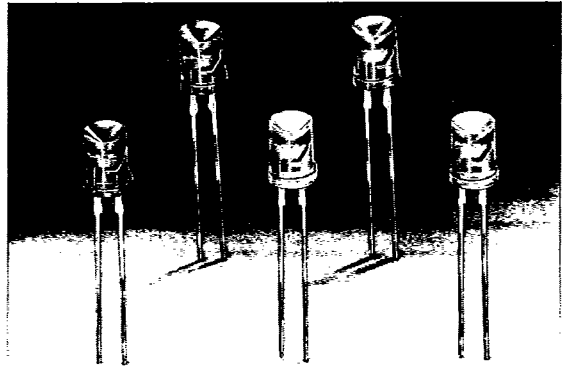

Package Dimensions

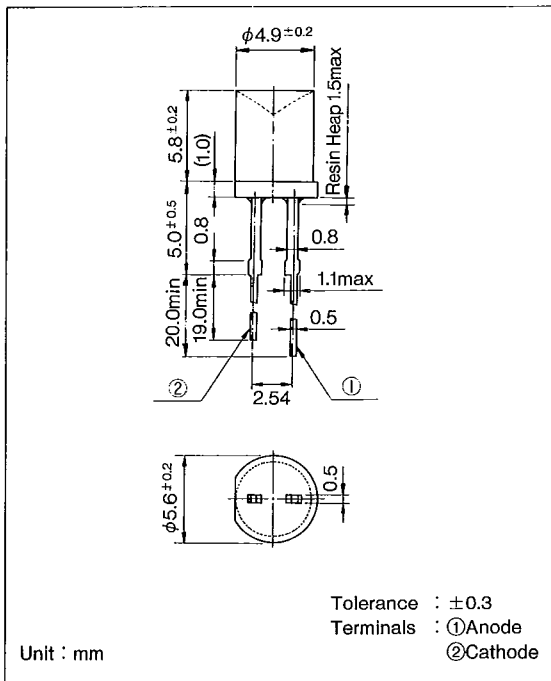

Intensity Ranks

Type No.	Intensity Min. (mcd)	Condition I _F (mA)	Color	
			Lens	Chip
SEL 1213 C	A	1.5	C	HIR
	B	1.9		
	C	2.4		
	D	3.1		
SEL 1413 E	A	3.0	G	HIG
	B	4.6		
	C	5.6		
	D	8.2		
SEL 1713 K	A	3.0	Y	Y
	B	6.3		
	C	8.3		
	D	11.1		
SEL 1813 A	A	2.0	O	A
	B	2.3		
	C	3.7		
	D	5.5		
SEL 1913 K	A	2.0	Y	O
	B	2.5		
	C	3.2		
	D	4.1		

G=Green O=Orange Y=Yellow A=Amber HIR=High Intensity Red HIG=High Intensity Green
C=Colorless Transparent

Electro-Optical Characteristics (Ta = 25°C)

Symbol	Description	Type No.	Min.	Typ.	Max.	Unit	Test Condition
I_v	Intensity	SEL 1213 C SEL 1413 E SEL 1713 K SEL 1813 A SEL 1913 K	1.5 3.0 3.0 2.0 2.0	3.1 8.2 11.1 5.5 4.1		mcd	$I_F=20$ (mA)
$2\theta_{1/2}$	Including Angle Between Half Intensity Points	SEL 1213 C SEL 1413 E SEL 1713 K SEL 1813 A SEL 1913 K		(160°)		Deg	$I_F=10$ (mA) See Note 1
λ_P	Peak Wavelength	SEL 1213 C SEL 1413 E SEL 1713 K SEL 1813 A SEL 1913 K		635 560 570 612 583		nm	$I_F=10$ (mA)
$\Delta\lambda$	Spectral Line Halfwidth	SEL 1213 C SEL 1413 E SEL 1713 K SEL 1813 A SEL 1913 K		40 28 40 40 36		nm	
λ_d	Dominant Wavelength	SEL 1213 C SEL 1413 E SEL 1713 K SEL 1813 A SEL 1913 K		626 562 566 608 585		nm	See Note 2
C	Capacitance	SEL 1213 C SEL 1413 E SEL 1713 K SEL 1813 A SEL 1913 K		15 15 15 15 10		pF	$V_F=0$ $f=1$ (MHz)
V_F	DC Forward Voltage	SEL 1213 C SEL 1413 E SEL 1713 K SEL 1813 A SEL 1913 K	1.5	2.0	3.0	V	$I_F=10$ (mA)
V_R	DC Reverse Voltage	SEL 1213 C SEL 1413 E SEL 1713 K SEL 1813 A SEL 1913 K	5.0			V	$I_R=100$ (μA)

Notes : 1. $\theta_{1/2}$ is the off-axis angle at which the intensity is half the axial intensity.
 2. The dominant wavelength, λ_d , is derived from the CIE chromaticity diagram and it represents the single wavelength which defines the color of the device.

Absolute Maximum Ratings (Ta = 25°C)

Symbol	Description	Ratings	Unit
I _P	Peak Forward Current*1	100	mA
I _F	Max. DC Forward Current*2	30	mA
V _R	DC Reverse Voltage (I _R = 100μA)	5	V
I _{FP}	Transient Max. Peak Forward Current*3 (10μsec Pulse)	500	mA
T _{OP}	Operating Temp. Range	-55 to +100	°C
T _{STG}	Storage Temp. Range	-55 to +100	
T _{Sld}	Lead Soldering Temp. (more than 4.0mm from body)	260°C for 5 seconds	

- Notes :
1. See Figure 4
 2. This current derates linearly from 25°C at 0.33 mA/°C
 3. Only for one pulse

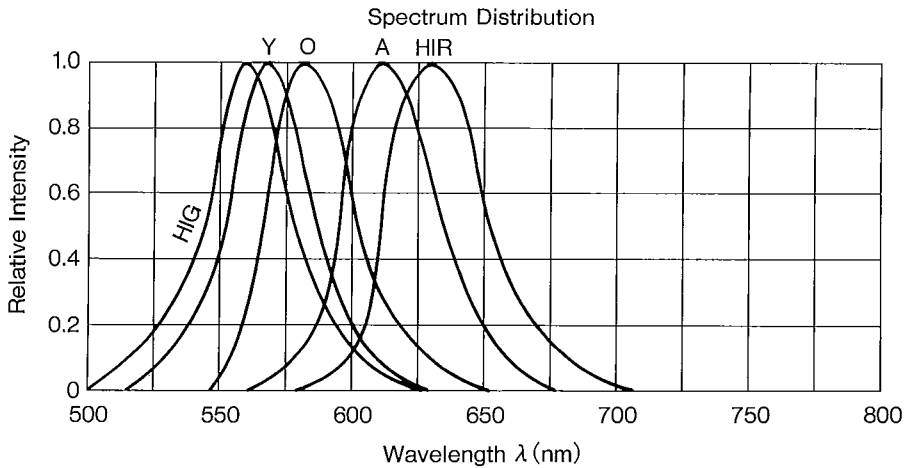

Fig. 1 : Relative Intensity vs. Wavelength

Individual Specifications

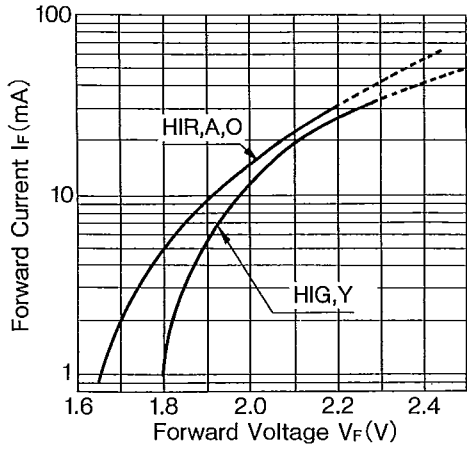

Fig.2 : Forward Current vs. Forward Voltage

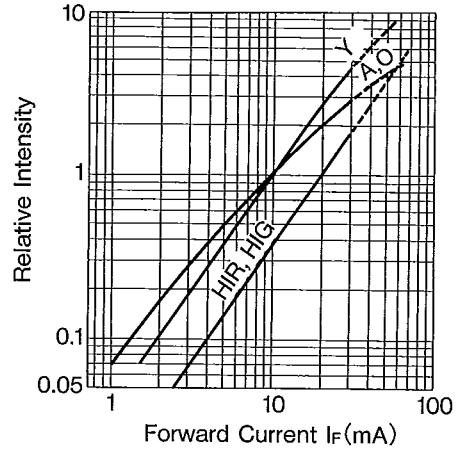

Fig.3 : Relative Intensity vs. Forward Current

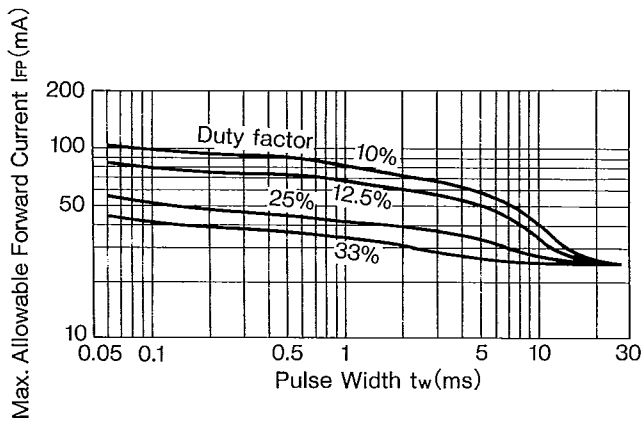

Fig.4 : Max. Allowable Forward Current vs. Pulse Width

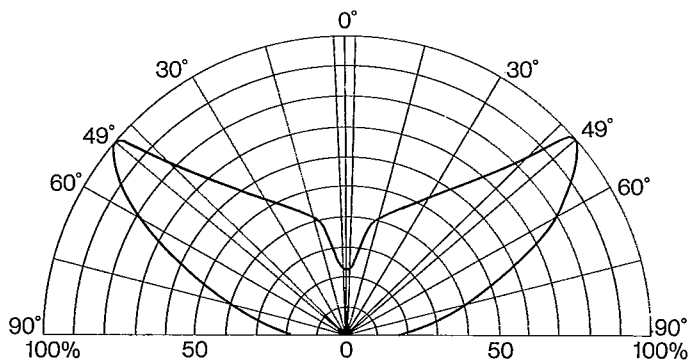

Fig.5 : Viewing Angle