

## Features

- **Low Voltage and Standard Voltage Operation**
  - 5.0 ( $V_{CC} = 4.5V$  to  $5.5V$ )
  - 2.7 ( $V_{CC} = 2.7V$  to  $5.5V$ )
  - 2.5 ( $V_{CC} = 2.5V$  to  $5.5V$ )
- **User Selectable Internal Organization**
  - 1K: 128 x 8 or 64 x 16
  - 2K: 256 x 8 or 128 x 16
  - 4K: 512 x 8 or 256 x 16
- **4-Wire Serial Interface**
- **Self-Timed Write Cycle (10 ms max)**
- **High Reliability**
  - **Endurance: 1 Million Write Cycles**
  - **Data Retention: 100 Years**
  - **ESD Protection: >4000V**
- **8-Pin PDIP and 8-Pin EIAJ SOIC Packages**

## Description

The AT59C11/22/13 provides 1024/2048/4096 bits of serial EEPROM (Electrically Erasable Programmable Read Only Memory) organized as 64/128/256 words of 16 bits each, when the ORG Pin is connected to  $V_{CC}$  and 128/256/512 words of 8 bits each when it is tied to ground. The device is optimized for use in many industrial and commercial applications where low power and low voltage operation are essential. The AT59C11/22/13 is available in space saving 8-pin PDIP and 8-pin EIAJ SOIC packages.

The AT59C11/22/13 is enabled through the Chip Select pin (CS), and accessed via a 4-wire serial interface consisting of Data Input (DI), Data Output (DO), and Clock (CLK). Upon receiving a READ instruction at DI, the address is decoded and the data is clocked out serially on the data output pin DO, the WRITE cycle is completely self-timed and no separate ERASE cycle is required before WRITE. The WRITE cycle is only enabled when the part is in the ERASE/WRITE ENABLE state. Ready/Busy status can be monitored upon completion of a programming operation by polling the Ready/Busy pin.

The AT59C11/22/13 is available in  $5.0V \pm 10\%$ , 2.7V to 5.5V and 2.5V to 5.5V versions.

## Pin Configurations

Pin Name	Function
CS	Chip Select
CLK	Serial Data Clock
DI	Serial Data Input
DO	Serial Data Output
GND	Ground
VCC	Power Supply
ORG	Internal Organization
RDY/BUSY	Status Output

8-Pin PDIP

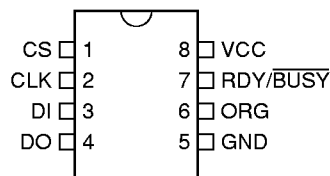

8-Pin SOIC

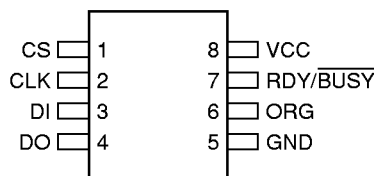

## 4-Wire Serial EEPROMs

1K (128 x 8 or 64 x 16)

2K (256 x 8 or 128 x 16)

4K (512 x 8 or 256 x 16)

**AT59C11**

**AT59C22**

**AT59C13**



## Absolute Maximum Ratings\*

Operating Temperature .....	-55°C to +125°C
Storage Temperature .....	-65°C to +150°C
Voltage on Any Pin with Respect to Ground .....	-1.0V to +7.0V
Maximum Operating Voltage.....	6.25V
DC Output Current.....	5.0 mA

\*NOTICE: Stresses beyond those listed under "Absolute Maximum Ratings" may cause permanent damage to the device. This is a stress rating only and functional operation of the device at these or any other conditions beyond those indicated in the operational sections of this specification is not implied. Exposure to absolute maximum rating conditions for extended periods may affect device reliability

## Block Diagram<sup>(1)</sup>

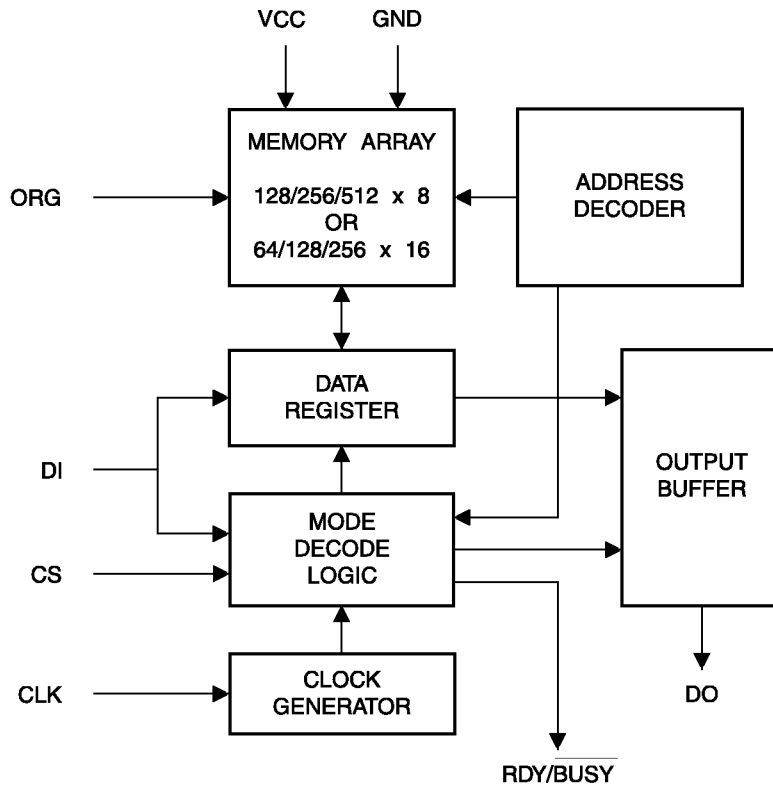

Note: 1. When the ORG pin is connected to  $V_{CC}$ , the x 16 organization is selected. When it is connected to ground, the x 8 organization is selected. If the ORG pin is left unconnected, then an internal pullup device will select the x 16 organization.

## Pin Capacitance<sup>(1)</sup>

Applicable over recommended operating range from  $T_A = 25^\circ\text{C}$ ,  $f = 1.0\text{ MHz}$ ,  $V_{CC} = +5.0\text{V}$  (unless otherwise noted).

Symbol	Test Conditions	Max	Units	Conditions
$C_{OUT}$	Output Capacitance (DO)	5	pF	$V_{OUT} = 0\text{V}$
$C_{IN}$	Input Capacitance (CS, CLK, DI, RDY/ $\overline{\text{BUSY}}$ )	5	pF	$V_{IN} = 0\text{V}$

Note: 1. This parameter is characterized and is not 100% tested.

## DC Characteristics

Applicable over recommended operating range from:  $T_{AI} = -40^\circ\text{C}$  to  $+85^\circ\text{C}$ ,  $V_{CC} = +2.5\text{V}$  to  $+5.5\text{V}$ ,  
 $T_{AC} = 0^\circ\text{C}$  to  $+70^\circ\text{C}$ ,  $V_{CC} = +2.5\text{V}$  to  $+5.5\text{V}$  (unless otherwise noted).

Symbol	Parameter	Test Condition	Min	Typ	Max	Units
$V_{CC1}$	Supply Voltage		1.8		5.5	V
$V_{CC2}$	Supply Voltage		2.5		5.5	V
$V_{CC3}$	Supply Voltage		2.7		5.5	V
$V_{CC4}$	Supply Voltage		4.5		5.5	V
$I_{CC}$	Supply Current	$V_{CC} = 5.0\text{V}$	READ at 1.0 MHz	0.5	2.0	mA
			WRITE at 1.0 MHz	0.5	2.0	mA
$I_{SB1}$	Standby Current	$V_{CC} = 2.5\text{V}$	CS = 0V	6.0	10.0	$\mu\text{A}$
$I_{SB2}$	Standby Current	$V_{CC} = 2.7\text{V}$	CS = 0V	6.0	10.0	$\mu\text{A}$
$I_{SB3}$	Standby Current	$V_{CC} = 5.0\text{V}$	CS = 0V	21.0	30.0	$\mu\text{A}$
$I_{IL}$	Input Leakage	$V_{IN} = 0\text{V}$ to $V_{CC}$		0.1	1.0	$\mu\text{A}$
$I_{OL}$	Output Leakage	$V_{IN} = 0\text{V}$ to $V_{CC}$		0.1	1.0	$\mu\text{A}$
$V_{IL1}^{(1)}$	Input Low Voltage	$4.5\text{V} \leq V_{CC} \leq 5.5\text{V}$		-0.6	0.8	V
$V_{IH1}^{(1)}$	Input High Voltage			2.0	$V_{CC} + 1$	
$V_{IL2}^{(1)}$	Input Low Voltage	$2.5\text{V} \leq V_{CC} \leq 2.7\text{V}$		-0.6	$V_{CC} \times 0.3$	V
$V_{IH2}^{(1)}$	Input High Voltage			$V_{CC} \times 0.7$	$V_{CC} + 1$	
$V_{OL1}$	Output Low Voltage	$4.5\text{V} \leq V_{CC} \leq 5.5\text{V}$	$I_{OL} = 2.1\text{ mA}$ $I_{OH} = 0.4\text{ mA}$	2.4	0.4	V
$V_{OH1}$	Output High Voltage					
$V_{OL2}$	Output Low Voltage	$2.5\text{V} \leq V_{CC} \leq 2.7\text{V}$	$I_{OL} = 0.15\text{ mA}$ $I_{OH} = -0.1\text{ mA}$	$V_{CC} - 0.2$	0.2	V
$V_{OH2}$	Output High Voltage					

Note: 1.  $V_{IL}$  min and  $V_{IH}$  max are reference only and are not tested.



## AC Characteristics

Applicable over recommended operating range from  $T_A = -40^{\circ}\text{C}$  to  $+85^{\circ}\text{C}$ ,  $V_{CC} = +2.5\text{V}$  to  $+5.5\text{V}$ ,  $CL = 1$  TTL Gate and  $100\text{ pF}$  (unless otherwise noted).

Symbol	Parameter	Test Condition	Min	Typ	Max	Units
$f_{CLK}$	CLK Clock Frequency	$4.5\text{V} \leq V_{CC} \leq 5.5\text{V}$	0		1	MHz
		$2.7\text{V} \leq V_{CC} \leq 5.5\text{V}$	0		1	
		$2.5\text{V} \leq V_{CC} \leq 5.5\text{V}$	0		0.5	
		$1.8\text{V} \leq V_{CC} \leq 5.5\text{V}$	0		0.25	
$t_{CKH}$	CLK High Time	$4.5\text{V} \leq V_{CC} \leq 5.5\text{V}$	250			ns
		$2.7\text{V} \leq V_{CC} \leq 5.5\text{V}$	250			
		$2.5\text{V} \leq V_{CC} \leq 5.5\text{V}$	500			
		$1.8\text{V} \leq V_{CC} \leq 5.5\text{V}$	1000			
$t_{CKL}$	CLK Low Time	$4.5\text{V} \leq V_{CC} \leq 5.5\text{V}$	250			ns
		$2.7\text{V} \leq V_{CC} \leq 5.5\text{V}$	250			
		$2.5\text{V} \leq V_{CC} \leq 5.5\text{V}$	500			
		$1.8\text{V} \leq V_{CC} \leq 5.5\text{V}$	1000			
$t_{CS}$	Minimum CS Low Time	$4.5\text{V} \leq V_{CC} \leq 5.5\text{V}$	250			ns
		$2.7\text{V} \leq V_{CC} \leq 5.5\text{V}$	250			
		$2.5\text{V} \leq V_{CC} \leq 5.5\text{V}$	500			
		$1.8\text{V} \leq V_{CC} \leq 5.5\text{V}$	1000			
$t_{CSS}$	CS Setup Time	Relative to SK				ns
		$4.5\text{V} \leq V_{CC} \leq 5.5\text{V}$	50			
		$2.7\text{V} \leq V_{CC} \leq 5.5\text{V}$	50			
		$2.5\text{V} \leq V_{CC} \leq 5.5\text{V}$	100			
$t_{DIS}$	DI Setup Time	Relative to SK				ns
		$4.5\text{V} \leq V_{CC} \leq 5.5\text{V}$	100			
		$2.7\text{V} \leq V_{CC} \leq 5.5\text{V}$	100			
		$2.5\text{V} \leq V_{CC} \leq 5.5\text{V}$	200			
$t_{CSH}$	CS Hold Time	Relative to SK				ns
		$4.5\text{V} \leq V_{CC} \leq 5.5\text{V}$	0			
		$2.7\text{V} \leq V_{CC} \leq 5.5\text{V}$	0			
		$2.5\text{V} \leq V_{CC} \leq 5.5\text{V}$	0			
$t_{DIH}$	DI Hold Time	Relative to SK				ns
		$4.5\text{V} \leq V_{CC} \leq 5.5\text{V}$	100			
		$2.7\text{V} \leq V_{CC} \leq 5.5\text{V}$	100			
		$2.5\text{V} \leq V_{CC} \leq 5.5\text{V}$	200			
$t_{PD1}$	Output Delay to '1'	AC Test				ns
		$4.5\text{V} \leq V_{CC} \leq 5.5\text{V}$			250	
		$2.7\text{V} \leq V_{CC} \leq 5.5\text{V}$			250	
		$2.5\text{V} \leq V_{CC} \leq 5.5\text{V}$			500	
$t_{PDO}$	Output Delay to '0'	AC Test				ns
		$4.5\text{V} \leq V_{CC} \leq 5.5\text{V}$			250	
		$2.7\text{V} \leq V_{CC} \leq 5.5\text{V}$			250	
		$2.5\text{V} \leq V_{CC} \leq 5.5\text{V}$			500	
$t_{RBD}$	RDY/ $\overline{\text{BUSY}}$ Delay to Status Valid	AC Test				ns
		$4.5\text{V} \leq V_{CC} \leq 5.5\text{V}$			250	
		$2.7\text{V} \leq V_{CC} \leq 5.5\text{V}$			250	
		$2.5\text{V} \leq V_{CC} \leq 5.5\text{V}$			500	
$t_{CZ}$	CS to DO in High Impedance	AC Test				ns
		CS = $V_{IL}$				
		$4.5\text{V} \leq V_{CC} \leq 5.5\text{V}$			100	
		$2.7\text{V} \leq V_{CC} \leq 5.5\text{V}$			100	
$t_{WC}$	Write Cycle Time					ms
			0.1		10	
Endurance <sup>(1)</sup>	5.0V, 25°C, Page Mode		1M			Write Cycles

Note: 1. This parameter is characterized and is not 100% tested.

### Instruction Set for the AT59C11

Instruction	SB	Op Code	Address		Data		Comments
			x 8	x 16	x 8	x 16	
READ	1	10XX	A <sub>6</sub> - A <sub>0</sub>	A <sub>5</sub> - A <sub>0</sub>			Reads data stored in memory, at specified address.
EWEN	1	0011	XXXXXXXX	XXXXXX			Write enable must precede all programming modes.
WRITE	1	X1XX	A <sub>6</sub> - A <sub>0</sub>	A <sub>5</sub> - A <sub>0</sub>	D <sub>7</sub> - D <sub>0</sub>	D <sub>15</sub> - D <sub>0</sub>	Writes memory location A <sub>n</sub> - A <sub>0</sub> .
ERAL	1	0010	XXXXXXXX	XXXXXX			Erases all memory locations. Valid only at V <sub>CC</sub> = 4.5V to 5.5V.
WRAL	1	0001	XXXXXXXX	XXXXXX	D <sub>7</sub> - D <sub>0</sub>	D <sub>15</sub> - D <sub>0</sub>	Writes all memory locations. Valid only at V <sub>CC</sub> = 4.5V to 5.5V.
EWDS	1	0000	XXXXXXXX	XXXXXX			Disables all programming instructions.

### Instruction Set for the AT59C22

Instruction	SB	Op Code	Address		Data		Comments
			x 8	x 16	x 8	x 16	
READ	1	10XX	A <sub>7</sub> - A <sub>0</sub>	A <sub>6</sub> - A <sub>0</sub>			Reads data stored in memory, at specified address.
EWEN	1	0011	XXXXXXXX	XXXXXXXX			Write enable must precede all programming modes.
WRITE	1	X1XX	A <sub>7</sub> - A <sub>0</sub>	A <sub>6</sub> - A <sub>0</sub>	D <sub>7</sub> - D <sub>0</sub>	D <sub>15</sub> - D <sub>0</sub>	Writes memory location A <sub>n</sub> - A <sub>0</sub> .
ERAL	1	0010	XXXXXXXX	XXXXXXXX			Erases all memory locations. Valid only at V <sub>CC</sub> = 4.5V to 5.5V.
WRAL	1	0001	XXXXXXXX	XXXXXXXX	D <sub>7</sub> - D <sub>0</sub>	D <sub>15</sub> - D <sub>0</sub>	Writes all memory locations. Valid when V <sub>CC</sub> = 5.0V ± 10% and Disable Register cleared.
EWDS	1	0000	XXXXXXXX	XXXXXXXX			Disables all programming instructions.

## Instruction Set for the AT59C13

Instruction	SB	Op Code	Address		Data		Comments
			x 8	x 16	x 8	x 16	
READ	1	10XX	A <sub>8</sub> - A <sub>0</sub>	A <sub>7</sub> - A <sub>0</sub>			Reads data stored in memory, at specified address.
EWEN	1	0011	XXXXXXXXXX	XXXXXXXXXX			Write enable must precede all programming modes.
WRITE	1	X1XX	A <sub>8</sub> - A <sub>0</sub>	A <sub>7</sub> - A <sub>0</sub>	D <sub>7</sub> - D <sub>0</sub>	D <sub>15</sub> - D <sub>0</sub>	Writes memory location A <sub>n</sub> - A <sub>0</sub> .
ERAL	1	0010	XXXXXXXXXX	XXXXXXXXXX			Erases all memory locations. Valid only at V <sub>CC</sub> = 4.5V to 5.5V.
WRAL	1	0001	XXXXXXXXXX	XXXXXXXXXX	D <sub>7</sub> - D <sub>0</sub>	D <sub>15</sub> - D <sub>0</sub>	Writes all memory locations. Valid when V <sub>CC</sub> = 5.0V ± 10% and Disable Register cleared.
EWDS	1	0000	XXXXXXXXXX	XXXXXXXXXX			Disables all programming instructions.

## Functional Description

The AT59C11/22/13 are accessed via a simple and versatile 4-wire serial communication interface. Device operation is controlled by six instructions issued by the host processor. **A valid instruction starts with a rising edge of CS** and consists of a Start Bit (logic "1") followed by the appropriate Op Code and the desired memory Address location.

**READ (READ):** The Read (READ) instruction contains the Address code for the memory location to be read. After the instruction and address are decoded, data from the selected memory location is available at the serial output pin DO. Output data changes are synchronized with the rising edges of serial clock CLK. It should be noted that a dummy bit (logic "0") precedes the 8- or 16-bit data output string.

**ERASE/WRITE (EWEN):** To assure data integrity, the part automatically goes into the Erase/Write Disable (EWDS) state when power is first applied. An Erase/Write Enable (EWEN) instruction must be executed first before any programming instructions can be carried out. Please note that once in the Erase/Write Enable state, programming remains enabled until an Erase/Write Disable (EWDS) instruction is executed or V<sub>CC</sub> power is removed from the part.

**WRITE (WRITE):** The Write (WRITE) instruction contains the 8 or 16 bits of data to be written into the specified memory location. The self-timed programming cycle, t<sub>WP</sub>, starts

after the last bit of data is received at serial data input pin DI. The Ready/Busy status of the AT59C11/22/13 can be determined by polling the RDY/BUSY pin. A logic "0" at RDY/BUSY indicates that programming is still in progress. A logic "1" indicates that the memory location at the specified address has been written with the data pattern contained in the instruction and the part is ready for further instructions.

**ERASE ALL (ERAL):** The Erase All (ERAL) instruction programs every bit in the memory array to the logic "1" state and is primarily used for testing purposes. The Ready/Busy status of the AT59C11/22/13 can be determined by polling the RDY/BUSY pin. The ERAL instruction is valid only at V<sub>CC</sub> = 5.0V ± 10%.

**WRITE ALL (WRAL):** The Write All (WRAL) instruction programs all memory locations with the data patterns specified in the instruction. The Ready/Busy status of the AT59C11/22/13 can be determined by polling the RDY/BUSY pin. The WRAL instruction is valid only at V<sub>CC</sub> = 5.0V ± 10%.

**ERASE/WRITE DISABLE (EWDS):** To protect against accidental data disturb, the Erase/Write Disable (EWDS) instruction disables all programming modes and should be executed after all programming operations. The operation of the READ instruction is independent of both the EWEN and EWDS instructions and can be executed at any time.

## Timing Diagrams

### Synchronous Data Timing

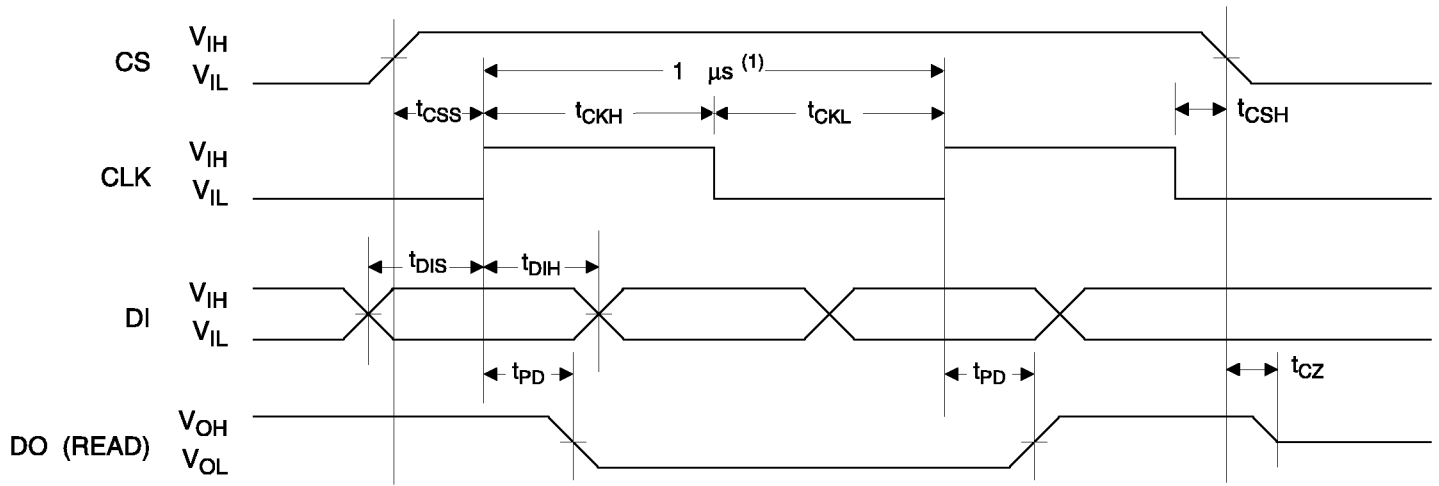

Note: 1. This is the minimum CLK period.

## Organization Key for Timing Diagrams

I/O	Density 1K		Density 2K		Density 4K	
	x 8	x 16	x 8	x 16	x 8	x 16
$A_N$	$A_6$	$A_5$	$A_7$	$A_6$	$A_8$	$A_7$
$D_N$	$D_7$	$D_{15}$	$D_7$	$D_{15}$	$D_7$	$D_{15}$

### READ Timing

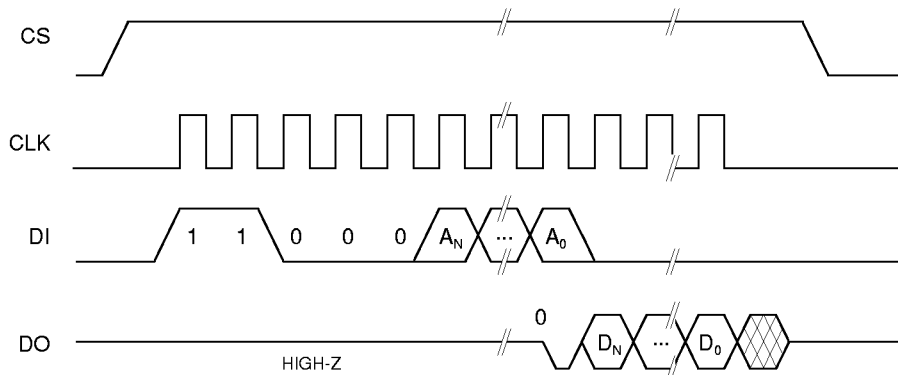

### WRITE Timing

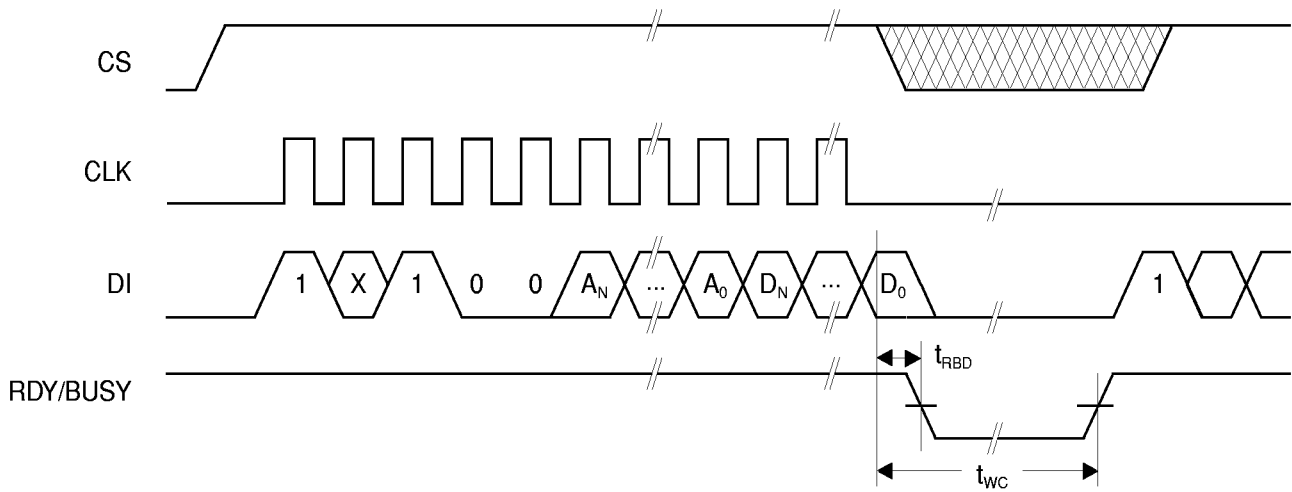

### EWEN/EWDS Timing

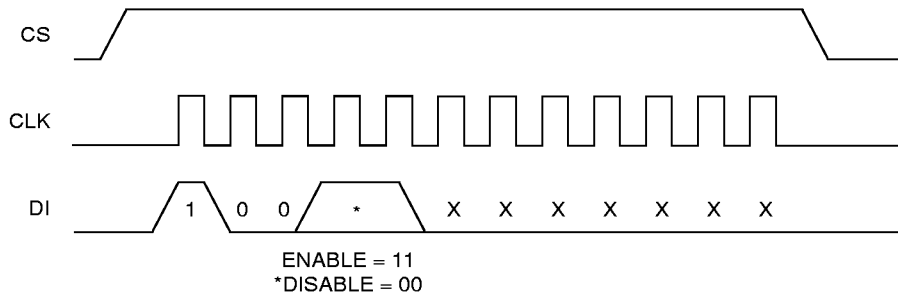



**ERAL Timing**

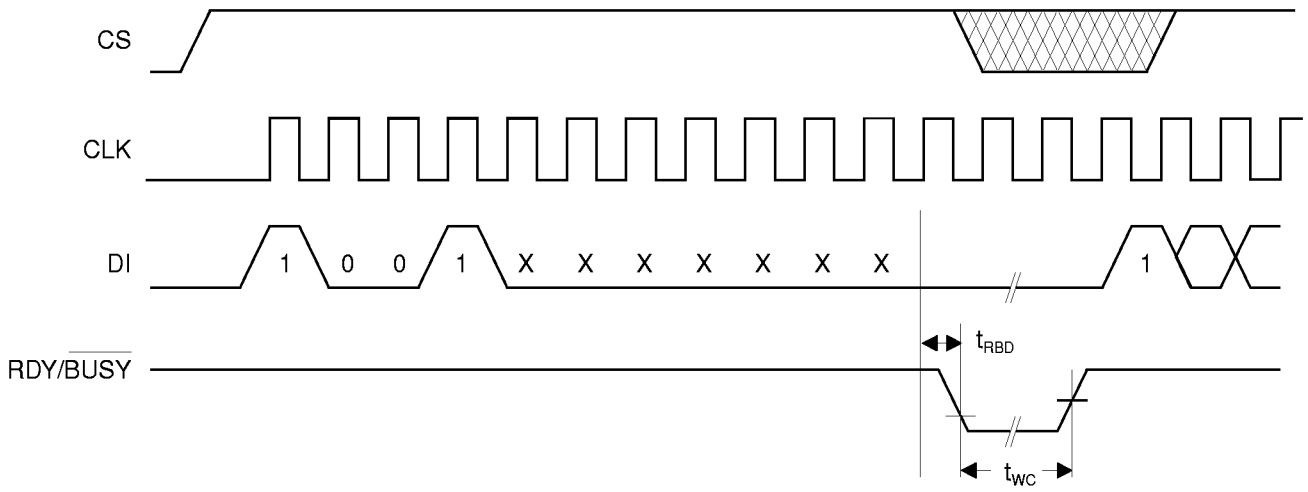

**WRAL Timing**

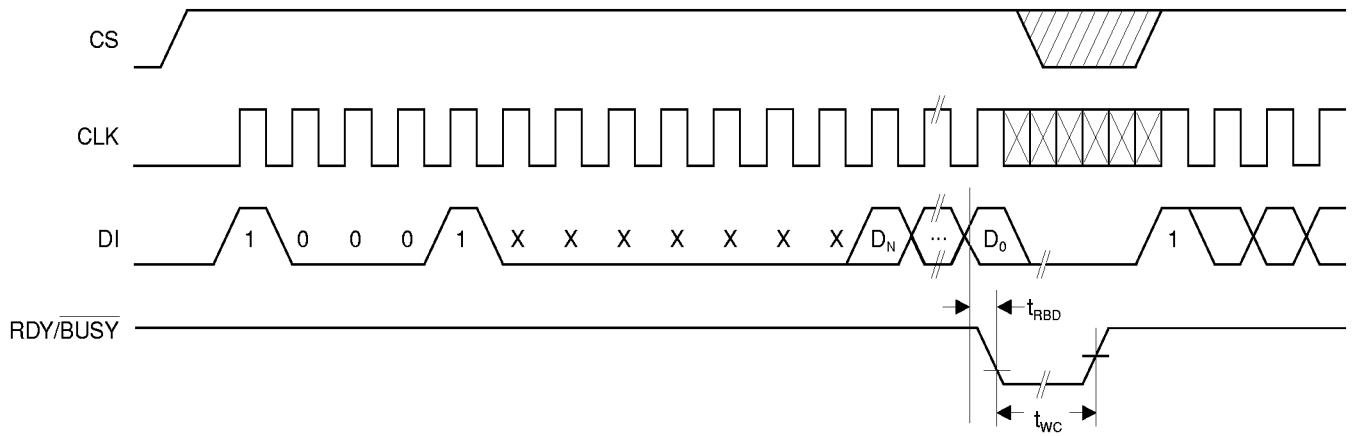



## AT59C11 Ordering Information

$t_{WC}$ (max) (ms)	$I_{CC}$ (max) ( $\mu A$ )	$I_{SB}$ (max) ( $\mu A$ )	$f_{MAX}$ (kHz)	Ordering Code	Package	Operation Range
10	2000	30.0	1000	AT59C11-10PC AT59C11W-10SC	8P3 8S2	Commercial (0°C to 70°C)
		30.0	1000	AT59C11-10PI AT59C11W-10SI	8P3 8S2	Industrial (-40°C to 85°C)
10	800	10.0	1000	AT59C11-10PC-2.7 AT59C11W-10SC-2.7	8P3 8S2	Commercial (0°C to 70°C)
		10.0	1000	AT59C11-10PI-2.7 AT59C11W-10SI-2.7	8P3 8S2	Industrial (-40°C to 85°C)
10	600	10.0	500	AT59C11-10PC-2.5 AT59C11W-10SC-2.5	8P3 8S2	Commercial (0°C to 70°C)
		10.0	500	AT59C11-10PI-2.5 AT59C11W-10SI-2.5	8P3 8S2	Industrial (-40°C to 85°C)

Package Type	
<b>8P3</b>	8-Lead, 0.300" Wide, Plastic Dual Inline Package (PDIP)
<b>8S2</b>	8-Lead, 0.200" Wide, Plastic Gull Wing Small Outline (EIAJ SOIC)
Options	
<b>Blank</b>	Standard Device (4.5V to 5.5V)
<b>-2.7</b>	Low-Voltage (2.7V to 5.5V)
<b>-2.5</b>	Low-Voltage (2.5V to 5.5V)

**AT59C22 Ordering Information**

$t_{WC}$ (max) (ms)	$I_{CC}$ (max) ( $\mu A$ )	$I_{SB}$ (max) ( $\mu A$ )	$f_{MAX}$ (kHz)	Ordering Code	Package	Operation Range
10	2000	30.0	1000	AT59C22-10PC AT59C22W-10SC	8P3 8S2	Commercial (0°C to 70°C)
		30.0	1000	AT59C22-10PI AT59C22W-10SI	8P3 8S2	Industrial (-40°C to 85°C)
10	800	10.0	1000	AT59C22-10PC-2.7 AT59C22W-10SC-2.7	8P3 8S2	Commercial (0°C to 70°C)
		10.0	1000	AT59C22-10PI-2.7 AT59C22W-10SI-2.7	8P3 8S2	Industrial (-40°C to 85°C)
10	600	10.0	500	AT59C22-10PC-2.5 AT59C22W-10SC-2.5	8P3 8S2	Commercial (0°C to 70°C)
		10.0	500	AT59C22-10PI-2.5 AT59C22W-10SI-2.5	8P3 8S2	Industrial (-40°C to 85°C)

Package Type	
<b>8P3</b>	8-Lead, 0.300" Wide, Plastic Dual Inline Package (PDIP)
<b>8S2</b>	8-Lead, 0.200" Wide, Plastic Gull Wing Small Outline (EIAJ SOIC)
Options	
<b>Blank</b>	Standard Device (4.5V to 5.5V)
<b>-2.7</b>	Low-Voltage (2.7V to 5.5V)
<b>-2.5</b>	Low-Voltage (2.5V to 5.5V)





## AT59C13 Ordering Information

$t_{WC}$ (max) (ms)	$I_{CC}$ (max) ( $\mu A$ )	$I_{SB}$ (max) ( $\mu A$ )	$f_{MAX}$ (kHz)	Ordering Code	Package	Operation Range
10	2000	30.0	1000	AT59C13-10PC AT59C13W-10SC	8P3 8S2	Commercial (0°C to 70°C)
		30.0	1000	AT59C13-10PI AT59C13W-10SI	8P3 8S2	Industrial (-40°C to 85°C)
10	800	10.0	1000	AT59C13-10PC-2.7 AT59C13W-10SC-2.7	8P3 8S2	Commercial (0°C to 70°C)
		10.0	1000	AT59C13-10PI-2.7 AT59C13W-10SI-2.7	8P3 8S2	Industrial (-40°C to 85°C)
10	600	10.0	500	AT59C13-10PC-2.5 AT59C13W-10SC-2.5	8P3 8S2	Commercial (0°C to 70°C)
		10.0	500	AT59C13-10PI-2.5 AT59C13W-10SI-2.5	8P3 8S2	Industrial (-40°C to 85°C)

Package Type	
<b>8P3</b>	8-Lead, 0.300" Wide, Plastic Dual Inline Package (PDIP)
<b>8S2</b>	8-Lead, 0.200" Wide, Plastic Gull Wing Small Outline (EIAJ SOIC)
Options	
<b>Blank</b>	Standard Device (4.5V to 5.5V)
<b>-2.7</b>	Low-Voltage (2.7V to 5.5V)
<b>-2.5</b>	Low-Voltage (2.5V to 5.5V)

Packaging Information

**8P3**, 8-Lead, 0.300" Wide, Plastic Dual Inline Package (PDIP)

Dimensions in Inches and (Millimeters)  
JEDEC STANDARD MS-001 BA

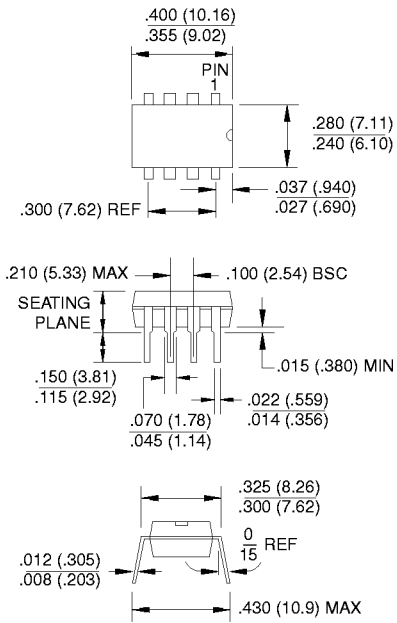

**8S2**, 8-Lead, 0.200" Wide, Plastic Gull Wing Small Outline (EIAJ SOIC)

Dimensions in Inches and (Millimeters)

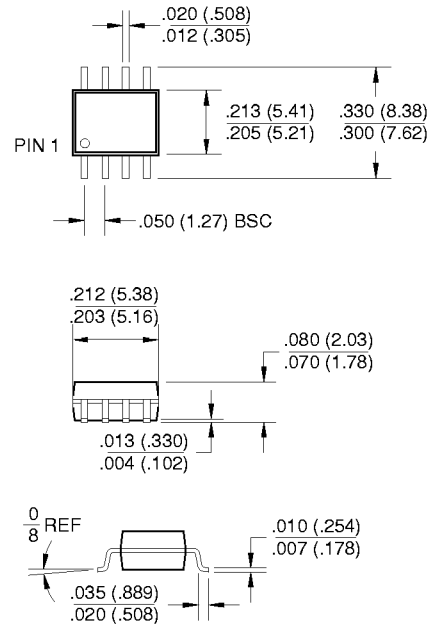



## Atmel Headquarters

### *Corporate Headquarters*

2325 Orchard Parkway  
San Jose, CA 95131  
TEL (408) 441-0311  
FAX (408) 487-2600

### *Europe*

Atmel U.K., Ltd.  
Coliseum Business Centre  
Riverside Way  
Camberley, Surrey GU15 3YL  
England  
TEL (44) 1276-686677  
FAX (44) 1276-686697

### *Asia*

Atmel Asia, Ltd.  
Room 1219  
Chinachem Golden Plaza  
77 Mody Road  
Tsimshatsui East  
Kowloon, Hong Kong  
TEL (852) 27219778  
FAX (852) 27221369

### *Japan*

Atmel Japan K.K.  
Tonetsu Shinkawa Bldg., 9F  
1-24-8 Shinkawa  
Chuo-ku, Tokyo 104-0033  
Japan  
TEL (81) 3-3523-3551  
FAX (81) 3-3523-7581

## Atmel Operations

### *Atmel Colorado Springs*

1150 E. Cheyenne Mtn. Blvd.  
Colorado Springs, CO 80906  
TEL (719) 576-3300  
FAX (719) 540-1759

### *Atmel Rousset*

Zone Industrielle  
13106 Rousset Cedex, France  
TEL (33) 4 42 53 60 00  
FAX (33) 4 42 53 60 01

---

### *Fax-on-Demand*

North America:  
1-(800) 292-8635  
International:  
1-(408) 441-0732

### *e-mail*

[literature@atmel.com](mailto:literature@atmel.com)

### *Web Site*

<http://www.atmel.com>

### *BBS*

1-(408) 436-4309

### © Atmel Corporation 1998.

Atmel Corporation makes no warranty for the use of its products, other than those expressly contained in the Company's standard warranty which is detailed in Atmel's Terms and Conditions located on the Company's website. The Company assumes no responsibility for any errors which may appear in this document, reserves the right to change devices or specifications detailed herein at any time without notice, and does not make any commitment to update the information contained herein. No licenses to patents or other intellectual property of Atmel are granted by the Company in connection with the sale of Atmel products, expressly or by implication. Atmel's products are not authorized for use as critical components in life support devices or systems.

Marks bearing ® and/or ™ are registered trademarks and trademarks of Atmel Corporation.

Terms and product names in this document may be trademarks of others.



Printed on recycled paper.

0173K-07/98/xM