

# AC640 • ACT640

## 54AC/74AC640 • 54ACT/74ACT640

### Octal Bidirectional Transceiver With 3-State Outputs

#### Description

The 'AC/'ACT640 octal bus transceiver is designed for asynchronous two-way communication between data buses. The device transmits data from bus A to bus B when  $T/\bar{R} = \text{HIGH}$ , or from bus B to bus A when  $T/\bar{R} = \text{LOW}$ . The enable input can be used to disable the device so the buses are effectively isolated.

- Bidirectional Data Path
- A and B Outputs Sink 24 mA/Source -24 mA
- 'ACT640 has TTL-Compatible Inputs

Ordering Code: See Section 6

#### Pin Names

- A<sub>0</sub> - A<sub>7</sub> Side A Inputs or 3-State Outputs
- $\bar{O}E$  Output Enable Input
- $T/\bar{R}$  Transmit/Receive Input
- B<sub>0</sub> - B<sub>7</sub> Side B Inputs or 3-State Outputs

#### Truth Table

$\bar{O}E$	$T/\bar{R}$	Applied Inputs	Valid Direction I/P→O/P	Output
H	X	X	X	X
L	H	H	A to B	L
L	H	L	A to B	H
L	L	H	B to A	L
L	L	L	B to A	H

H = HIGH Voltage Level  
L = LOW Voltage Level  
X = Immaterial

#### Connection Diagrams

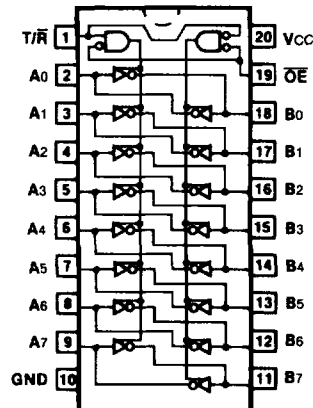

Pin Assignment for DIP, Flatpak and SOIC

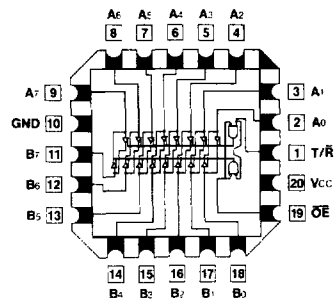

Pin Assignment for LCC

## DC Characteristics (unless otherwise specified)

Symbol	Parameter	54AC/ACT	74AC/ACT	Units	Conditions
I <sub>CC</sub>	Maximum Quiescent Supply Current	160	80	μA	V <sub>IN</sub> = V <sub>CC</sub> or Ground, V <sub>CC</sub> = 5.5 V, T <sub>A</sub> = Worst Case
I <sub>CC</sub>	Maximum Quiescent Supply Current	8.0	8.0	μA	V <sub>IN</sub> = V <sub>CC</sub> or Ground, V <sub>CC</sub> = 5.5 V, T <sub>A</sub> = 25°C
I <sub>CC(T)</sub>	Maximum Additional I <sub>CC</sub> /Input (ACT640)	1.6	1.5	mA	V <sub>IN</sub> = V <sub>CC</sub> - 2.1 V V <sub>CC</sub> = 5.5 V, T <sub>A</sub> = Worst Case

## AC Characteristics

Symbol	Parameter	V <sub>CC</sub> * (V)	74AC			54AC		74AC		Units	Fig. No.
			T <sub>A</sub> = +25°C C <sub>L</sub> = 50 pF			T <sub>A</sub> = -55°C to +125°C C <sub>L</sub> = 50 pF		T <sub>A</sub> = -40°C to +85°C C <sub>L</sub> = 50 pF			
			Min	Typ	Max	Min	Max	Min	Max		
t <sub>PLH</sub>	Propagation Delay A <sub>n</sub> to B <sub>n</sub> or B <sub>n</sub> to A <sub>n</sub>	3.3 5.0	5.5 4.0						ns	3-5	
t <sub>PHL</sub>	Propagation Delay A <sub>n</sub> to B <sub>n</sub> or B <sub>n</sub> to A <sub>n</sub>	3.3 5.0	5.5 4.0						ns	3-5	
t <sub>PZH</sub>	Output Enable Time	3.3 5.0	8.0 6.0						ns	3-7	
t <sub>PZL</sub>	Output Enable Time	3.3 5.0	7.5 5.5						ns	3-8	
t <sub>PHZ</sub>	Output Disable Time	3.3 5.0	7.0 6.0						ns	3-7	
t <sub>PLZ</sub>	Output Disable Time	3.3 5.0	7.5 6.0						ns	3-8	

\*Voltage Range 3.3 is 3.3 V ± 0.3 V  
Voltage Range 5.0 is 5.0 V ± 0.5 V

Military parameters given herein are for general references only. For current military specifications and subgroup testing information please request Fairchild's Table I data sheet from your Fairchild sales engineer or account representative.

# AC640 • ACT640

## AC Characteristics

Symbol	Parameter	Vcc* (V)	74ACT			54ACT		74ACT		Units	Fig. No.
			TA = +25°C CL = 50 pF			TA = -55°C to +125°C CL = 50 pF		TA = -40°C to +85°C CL = 50 pF			
			Min	Typ	Max	Min	Max	Min	Max		
tPLH	Propagation Delay An to Bn or Bn to An	5.0	5.0						ns	3-5	
tPHL	Propagation Delay An to Bn or Bn to An	5.0	5.0						ns	3-5	
tpZH	Output Enable Time	5.0	7.0						ns	3-7	
tpZL	Output Enable Time	5.0	6.0						ns	3-8	
tpHZ	Output Disable Time	5.0	6.5						ns	3-7	
tpLZ	Output Disable Time	5.0	6.0						ns	3-8	

\*Voltage Range 5.0 is 5.0 V ± 0.5 V

Military parameters given herein are for general references only. For current military specifications and subgroup testing information please request Fairchild's Table I data sheet from your Fairchild sales engineer or account representative.

## Capacitance

Symbol	Parameter	54/74AC/ACT	Units	Conditions
		Typ		
C <sub>IN</sub>	Input Capacitance	4.5	pF	Vcc = 5.5 V
C <sub>I/O</sub>	Input/Output Capacitance	15.0	pF	Vcc = 5.5 V
C <sub>PD</sub>	Power Dissipation Capacitance		pF	Vcc = 5.5 V