



Precision Monolithics Inc.

1.0 SCOPE

This specification covers the detail requirements for an ultra-low-offset voltage operational amplifier.

It is highly recommended that this data sheet be used as a baseline for new military or aerospace spec control drawings.

1.2 Part Number. The complete part numbers per Table I of this specification follow:

<u>Device</u>	<u>Part Number</u>	<u>Package</u>
A	OP-77AJ/883	J
B	OP-77BJ/883	J
A	OP-77AZ/883	Z
B	OP-77BZ/883	Z
B	OP-77BRC/883	RC

1.2.3 Case Outline.

<u>Letter</u>	<u>Case Outline (Lead finish per MIL-M-38510)</u>
J	8-lead metal can (TO-99)
Z	8-lead ceramic dual-in-line package (CERDIP)
RC	20-contact hermetic leadless chip carrier (LCC)

1.3 Absolute Maximum Ratings. ($T_A = 25^\circ\text{C}$, unless otherwise noted)

Supply Voltage.....	$\pm 22\text{V}$
Internal Power Dissipation	500mW
Differential Input Voltage.....	$\pm 30\text{V}$
Input Voltage (Note 1)	$\pm 22\text{V}$
Output Short-Circuit Duration	Indefinite
Storage Temperature Range.....	-65°C to $+150^\circ\text{C}$
Lead Temperature (Soldering, 60 sec).....	$+300^\circ\text{C}$
Operating Temperature Range	-55°C to $+125^\circ\text{C}$
DICE Junction Temperature Range (T_J)	-65°C to $+150^\circ\text{C}$

NOTES:

1. For supply voltages less than $\pm 22\text{V}$, the absolute maximum input voltage is equal to the supply voltages.

January 1988

5
OPERATIONAL AMPLIFIERS



1.5 Thermal Characteristics:

Thermal Resistance, TO-99 (J) package:

Junction-to-Case (θ_{JC}) = 45 °C/W MAX

Junction-to-Ambient (θ_{JA}) = 150 °C/W MAX

Thermal Resistance, CERDIP (Z) package:

Junction-to-Case (θ_{JC}) = 26 °C/W MAX

Junction-to Ambient (θ_{JA}) = 119 °C/W MAX

Thermal Resistance, LCC (RC) package:

Junction-to-Case (θ_{JC}) = 35 °C/W MAX

Junction-to Ambient (θ_{JA}) = 110 °C/W MAX

January 1988



TABLE 1

$V_S = \pm 15V$; $R_S = 50\Omega$; $V_{CM} = 0V$; $T_A = 25^\circ C$ unless otherwise specified.

Characteristics	Symbol	Special Conditions	OP-77/883				Units
			LIMITS A		LIMITS B		
			Min	Max	Min	Max	
Input Offset Voltage	V_{OS}		-	25	-	60	μV
		$-55^\circ C \leq T_A \leq +125^\circ C$	-	60	-	120	μV
Average Offset Voltage Drift	TCV_{OS}	$-55^\circ C \leq T_A \leq +125^\circ C$	-	0.3	-	0.6	$\mu V/^\circ C$
Input Offset Current	I_{OS}		-	1.5	-	2.8	nA
		$-55^\circ C \leq T_A \leq +125^\circ C$	-	2.2	-	4.5	nA
Input Bias Current	I_B		-0.2	2.0	-0.2	2.8	nA
		$-55^\circ C \leq T_A \leq +125^\circ C$	-0.2	4.0	-0.2	6.0	nA
Output Voltage Swing	V_O	$R_L \geq 10k\Omega$	± 13.5	-	± 13.5	-	V
		$R_L \geq 2k\Omega$	± 12.5	-	± 12.5	-	V
		$R_L \geq 1k\Omega$	± 12.0	-	± 12.0	-	V
		$R_L \geq 2k\Omega$	± 12.0	-	± 12.0	-	V
		$-55^\circ C \leq T_A \leq +125^\circ C$					
Supply Current	I_{SY}	No Load	-	2.0	-	2.0	mA
		No Load, $V_S = \pm 3V$	-	0.75	-	0.75	mA
Power Dissipation	P_d	No Load	-	60	-	60	mW
		No Load	-	75	-	75	mW
		$-55^\circ C \leq T_A \leq +125^\circ C$ No Load, $V_S = \pm 3V$	-	4.5	-	4.5	mW
Slew Rate	SR	$R_L \geq 2k\Omega, C_L = 50pF$	0.1	-	0.1	-	V/ μs
Common-Mode Rejection	CMR	$V_{CM} = IVR = \pm 13V$	120	-	116	-	dB
		$V_{CM} = IVR = \pm 13V$ $-55^\circ C \leq T_A \leq +125^\circ C$	120	-	110	-	dB
Input Voltage Range (Note 1)	IVR		± 13	-	± 13	-	V
		$-55^\circ C \leq T_A \leq +125^\circ C$	± 13	-	± 13	-	V

5
OPERATIONAL AMPLIFIERS



TABLE 1 (Continued)

$V_S = \pm 15V$; $R_S = 50\Omega$; $V_{CM} = 0V$; $T_A = 25^\circ C$ unless otherwise specified.

Characteristics	Symbol	Special Conditions	OP-77/883				Units
			LIMITS A		LIMITS B		
			Min	Max	Min	Max	
Power Supply Rejection Ratio	PSRR	$V_S = \pm 3V$ to $\pm 18V$ $V_S = \pm 3V$ to $\pm 18V$ $-55^\circ C \leq T_A \leq +125^\circ C$	--	3	--	3	$\mu V/V$
Input Noise Voltage (Note 2)	e_n	$f_O = 1Hz$ to $100Hz$	--	150	--	150	nV_{RMS}
Input Noise Current (Note 2)	i_n	$f_O = 1Hz$ to $100Hz$	--	8	--	8	pA_{RMS}
Open-Loop Voltage Gain	A_{VO}	$R_L \geq 2k\Omega$, $V_O = \pm 10V$	5000	--	2000	--	V/mV
		$R_L \geq 2k\Omega$, $V_O = \pm 10V$ $-55^\circ C \leq T_A \leq +125^\circ C$	2000	--	1000	--	V/mV
Small-Signal Bandwidth	BW	$A_{VCL} = +1$	0.4	--	0.4	--	MHz
Input Offset Adjustment	V_{OSadj+}	$R_p = 20k\Omega$	0.5	--	0.5	--	mV
	V_{OSadj-}	$R_p = 20k\Omega$	--	-0.5	--	-0.5	mV
Output Short Circuit	I_{SC+}		--	65	--	65	mA
	I_{SC-}		-65	--	-65	--	mA

NOTES:

1. IVR is defined as the V_{CM} range used for the CMR test.
2. This parameter is 100% tested.



TABLE 2

OP-77/883

**Electrical Test Requirements
For Class B Devices**

MIL-STD-883 Test Requirements	Subgroups (see Table 3)
Interim Electrical Parameters (pre Burn-In)	1
Final Electrical Test Parameters	1*, 2, 3, 4, 5, 6
Group A Test Requirements	1, 2, 3, 4, 5, 6, 7, 8

* PDA applies to Subgroup 1 only.
No other Subgroups are included in PDA.
 V_{OS} is excluded from PDA calculation.



TABLE 3

Group A Inspection

$V_S = \pm 15V$; $R_S = 50\Omega$; $V_{CM} = 0V$; $T_A = T_J$ unless otherwise specified.

Subgroup	Symbol	Special Conditions	OP-77/883				Units
			LIMITS A		LIMITS B		
			Min	Max	Min	Max	
Subgroup 1 $T_A = +25^\circ C$	I_{OS}		--	1.5	--	2.8	nA
	I_B		-0.2	2.0	-0.2	2.8	nA
	CMR	$V_{CM} = \pm 13V$	120	--	116	--	dB
	PSRR	$V_S = \pm 3V, \pm 18V$	--	3.0	--	3.0	$\mu V/V$
	A_{VO}	$R_L = 2k\Omega, V_O = \pm 10V$	5000	--	2000	-	V/mV
	V_O	$R_L = 10k\Omega$	± 13.5	--	± 13.5	--	V
		$R_L = 2k\Omega$	± 12.5	--	± 12.5	--	V
		$R_L = 1k\Omega$	± 12.0	--	± 12.0	--	V
	P_d	No Load	--	60	--	60	mW
		No Load, $V_S = \pm 3V$	--	4.5	--	4.5	mW
	V_{OSadj+}	$R_p = 20k\Omega$	0.5	--	0.5	--	mV
	V_{OSadj-}	$R_p = 20k\Omega$	--	-0.5	--	-0.5	mV
	I_{SC+}		--	65	--	65	mA
I_{SC-}		-65	--	-65	--	mA	
Subgroup 2 $T_A = +125^\circ C$	I_{OS}		--	2.2	--	4.5	nA
	I_B		-0.2	4.0	-0.2	6.0	nA
	CMR	$V_{CM} = \pm 13V$	120	--	110	--	dB
	PSRR	$V_S = \pm 3V, \pm 18V$	--	3.0	--	5.0	$\mu V/V$
	A_{VO}	$R_L = 2k\Omega, V_O = \pm 10V$	2000	--	1000	--	V/mV
	V_O	$R_L = 2k\Omega$	± 12	--	± 12	--	V



TABLE 3

Group A Inspection (Continued)

$V_S = \pm 15V$; $R_S = 50\Omega$; $V_{CM} = 0V$; $T_A = T_J$ unless otherwise specified.

Subgroup	Symbol	Special Conditions	OP-77/883				Units
			LIMITS A		LIMITS B		
			Min	Max	Min	Max	
Subgroup 2 $T_A = +125^\circ$ (Continued)	P_d	No Load	--	75	--	75	mW
Subgroup 3 $T_A = -55^\circ C$	All Tests, Limits and Conditions are the same as for Subgroup 2.						
Subgroup 4 $T_A = +25^\circ C$	V_{OS}		--	25	--	60	μV
Subgroup 5 $T_A = +125^\circ C$	V_{OS}		--	60	--	120	μV
Subgroup 6 $T_A = -55^\circ C$	V_{OS}		--	60	--	120	μV
Subgroup 7 $T_A = +25^\circ C$	BW	$A_{VCL} = +1$	0.4	--	0.4	--	MHz
	SR	$R_L = 2k\Omega, C_L = 50pF$	0.1	--	0.1	--	$V/\mu s$
Subgroup 8 $-55^\circ C \leq T_A \leq +125^\circ C$	TCV_{OS}		--	0.3	--	0.6	$\mu V/^\circ C$

5
OPERATIONAL AMPLIFIERS



3.2.1 Simplified Schematic and Pin Connections.

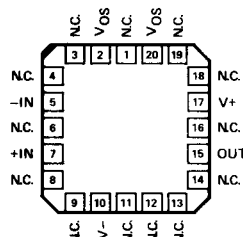
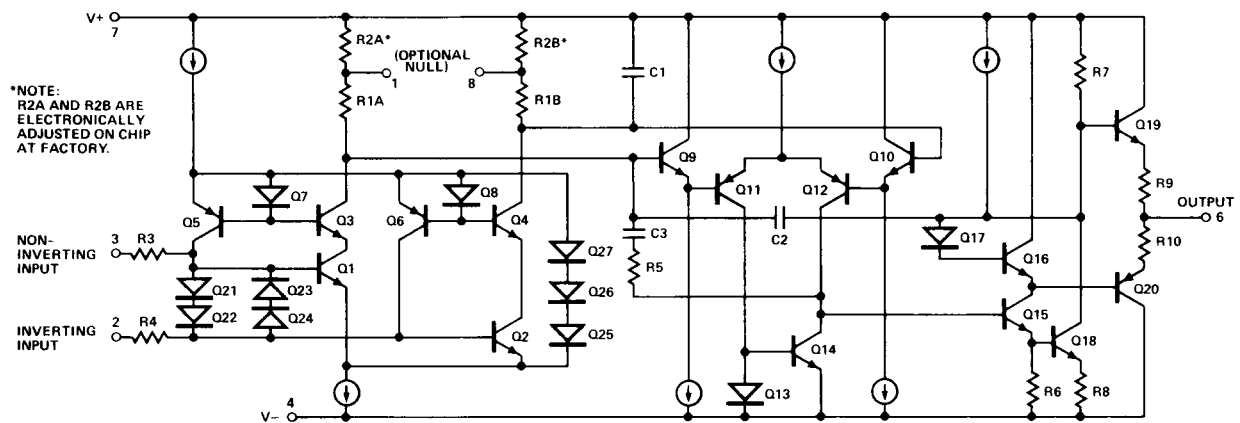

OP-77BRC/883
LCC
(RC-Suffix)

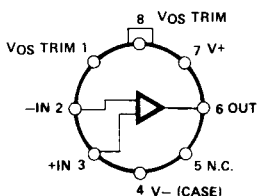

TO-99
(J-Suffix)

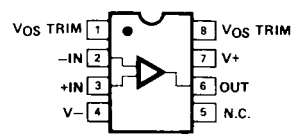

8-PIN HERMETIC DIP
(Z-Suffix)

3.2.4 Microcircuit Group Assignment. This microcircuit is covered by microcircuit group 61.

4.2 Life Test/Burn-In Circuit.

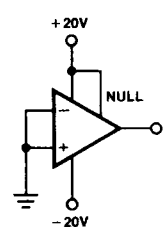

J AND Z PACKAGES