

REVISIONS

LTR	DESCRIPTION	DATE (YR-MO-DA)	APPROVED
A	Add device type 03. Add one vendor, CAGE 64155. Make changes to table I and throughout.	91-02-14	M. A. FRYE
B	Changes in accordance with 5962-R271-92.	92-11-20	M. A. FRYE
C	Changes in accordance with 5962-R016-97.	96-10-23	R. MONNIN
D	Changes in accordance with 5962-R253-97.	97-04-08	R. MONNIN
E	Drawing updated to reflect current requirements. - ro	02-06-20	R. MONNIN
F	Drawing updated as part of 5 year review. -rrp	09-01-13	R. HEBER

THE ORIGINAL FIRST SHEET OF THIS DRAWING HAS BEEN REPLACED.

REV																				
SHEET																				
REV																				
SHEET																				
REV STATUS OF SHEETS	REV SHEET	F	F	F	F	F	F	F	F	F	F									
		1	2	3	4	5	6	7	8	9										

PMIC N/A	PREPARED BY RICK C. OFFICER	<p align="center">DEFENSE SUPPLY CENTER COLUMBUS COLUMBUS, OHIO 43218-3990 http://www.dsc.dla.mil</p> <p>MICROCIRCUIT, LINEAR, PRECISION VOLTAGE REFERENCE, 2.5 VOLT, MONOLITHIC SILICON</p>																	
<p align="center">STANDARD MICROCIRCUIT DRAWING</p> <p>THIS DRAWING IS AVAILABLE FOR USE BY ALL DEPARTMENTS AND AGENCIES OF THE DEPARTMENT OF DEFENSE</p> <p align="center">AMSC N/A</p>	CHECKED BY CHARLES E. BESORE																		
	APPROVED BY MICHAEL A. FRYE																		
	DRAWING APPROVAL DATE 87-11-17																		
	REVISION LEVEL F	SIZE A	CAGE CODE 14933	5962-86861															
		SHEET 1 OF 9																	

1. SCOPE

1.1 Scope. This drawing describes device requirements for MIL-STD-883 compliant, non-JAN class level B microcircuits in accordance with MIL-PRF-38535, appendix A.

1.2 Part or Identifying Number (PIN). The complete PIN is as shown in the following example:

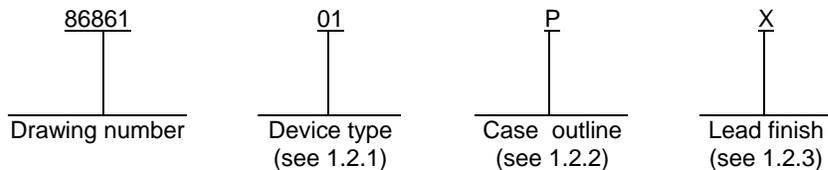

1.2.1 Device type(s). The device type(s) identify the circuit function as follows:

<u>Device type</u>	<u>Generic number</u>	<u>Circuit function</u>
01	580S, 1503	Precision 2.5 V reference (1%)
02	580T, 1503A	Precision 2.5 V reference (0.4%)
03	580U	Precision 2.5 V reference (0.4%)

1.2.2 Case outline(s). The case outline(s) are as designated in MIL-STD-1835 and as follows:

<u>Outline letter</u>	<u>Descriptive designator</u>	<u>Terminals</u>	<u>Package style</u>
P	GDIP1-T8 or CDIP2-T8	8	Dual in-line
X	See figure 1	3	Can
Y	MACY1-X3	3	Can

1.2.3 Lead finish. The lead finish is as specified in MIL-PRF-38535, appendix A.

1.3 Absolute maximum ratings.

Supply voltage (V _{CC})	40 V dc
Maximum power dissipation (P _D):	
Case P	600 mW ^{1/}
Case X	350 mW
Case Y	1.0 W
Storage temperature range	-65°C to +150°C
Lead temperature (soldering, 10 seconds)	+300°C
Junction temperature (T _J)	+175°C
Thermal resistance, junction-to-case (θ _{JC}):	
Case P	See MIL-STD-1835
Case X	30°C/W
Case Y	15°C/W
Thermal resistance, junction-to-ambient (θ _{JA}):	
Case X	150°C/W
Case Y	120°C/W

^{1/} Derate case P at 4.8 mW/°C above +25°C.

STANDARD MICROCIRCUIT DRAWING DEFENSE SUPPLY CENTER COLUMBUS COLUMBUS, OHIO 43218-3990	SIZE A		5962-86861
		REVISION LEVEL F	SHEET 2

1.4 Recommended operating conditions.

Supply voltage (V_{CC}) +4.5 V dc to +30 V dc
Ambient operating temperature range (T_A) -55°C to +125°C

2. APPLICABLE DOCUMENTS

2.1 Government specification, standards, and handbooks. The following specification, standards, and handbooks form a part of this drawing to the extent specified herein. Unless otherwise specified, the issues of these documents are those cited in the solicitation or contract.

DEPARTMENT OF DEFENSE SPECIFICATION

MIL-PRF-38535 - Integrated Circuits, Manufacturing, General Specification for.

DEPARTMENT OF DEFENSE STANDARDS

MIL-STD-883 - Test Method Standard Microcircuits.
MIL-STD-1835 - Interface Standard Electronic Component Case Outlines.

DEPARTMENT OF DEFENSE HANDBOOKS

MIL-HDBK-103 - List of Standard Microcircuit Drawings.
MIL-HDBK-780 - Standard Microcircuit Drawings.

(Copies of these documents are available online at <http://assist.daps.dla.mil/quicksearch/> or from the Standardization Document Order Desk, 700 Robbins Avenue, Building 4D, Philadelphia, PA 19111-5094.)

2.2 Order of precedence. In the event of a conflict between the text of this drawing and the references cited herein, the text of this drawing takes precedence. Nothing in this document, however, supersedes applicable laws and regulations unless a specific exemption has been obtained.

3. REQUIREMENTS

3.1 Item requirements. The individual item requirements shall be in accordance with MIL-PRF-38535, appendix A for non-JAN class level B devices and as specified herein. Product built to this drawing that is produced by a Qualified Manufacturer Listing (QML) certified and qualified manufacturer or a manufacturer who has been granted transitional certification to MIL-PRF-38535 may be processed as QML product in accordance with the manufacturers approved program plan and qualifying activity approval in accordance with MIL-PRF-38535. This QML flow as documented in the Quality Management (QM) plan may make modifications to the requirements herein. These modifications shall not affect form, fit, or function of the device. These modifications shall not affect the PIN as described herein. A "Q" or "QML" certification mark in accordance with MIL-PRF-38535 is required to identify when the QML flow option is used.

3.2 Design, construction, and physical dimensions. The design, construction, and physical dimensions shall be as specified in MIL-PRF-38535, appendix A and herein.

3.2.1 Case outlines. The case outlines shall be in accordance with 1.2.2 herein and figure 1.

3.2.2 Terminal connections. The terminal connections shall be as specified on figure 2.

3.3 Electrical performance characteristics. Unless otherwise specified herein, the electrical performance characteristics are as specified in table I and shall apply over the full ambient operating temperature range.

3.4 Electrical test requirements. The electrical test requirements shall be the subgroups specified in table II. The electrical tests for each subgroup are described in table I.

3.5 Marking. Marking shall be in accordance with MIL-PRF-38535, appendix A. The part shall be marked with the PIN listed in 1.2 herein. In addition, the manufacturer's PIN may also be marked. For packages where marking of the entire SMD PIN number is not feasible due to space limitations, the manufacturer has the option of not marking the "5962-" on the device.

STANDARD MICROCIRCUIT DRAWING DEFENSE SUPPLY CENTER COLUMBUS COLUMBUS, OHIO 43218-3990	SIZE A		5962-86861
		REVISION LEVEL F	SHEET 3

TABLE I. Electrical performance characteristics.

Test	Symbol	Conditions -55°C ≤ T _A ≤ +125°C V _{CC} = +15 V, I _L = 0 mA unless otherwise specified	Group A subgroups	Device type	Limits		Unit
					Min	Max	
Quiescent current	I _{CC}		1	01,02		2.0	mA
				03		1.5	
			2,3	All		2.0	
Output voltage	V _{OUT}	T _A = +25°C <u>1/</u>	1	All	2.475	2.525	V
			12	02,03	2.49	2.51	
Line regulation	VR _{LINE1}	V _{CC} = 7 V to 30 V, T _A = +25°C	1	01,02		±6	mV
				03		±2	
	VR _{LINE2}	V _{CC} = 4.5 V to 7 V, T _A = +25°C		01,02		±3	
				03		±1	
Load regulation	VR _{LOAD}	I _L = 0 mA to 10 mA, T _A = +25°C	1	All		±10	mV
Output voltage temperature coefficient	TCV _{OUT}	<u>1/</u>	2,3	01		±25	mV
				02		±11	
				03		±4.5	

1/ Measurements of output voltage temperature coefficient is acceptable for output voltage across temperature measurement (subgroups 2 and 3) or visa versa.

STANDARD MICROCIRCUIT DRAWING DEFENSE SUPPLY CENTER COLUMBUS COLUMBUS, OHIO 43218-3990	SIZE A		5962-86861
		REVISION LEVEL F	SHEET 4

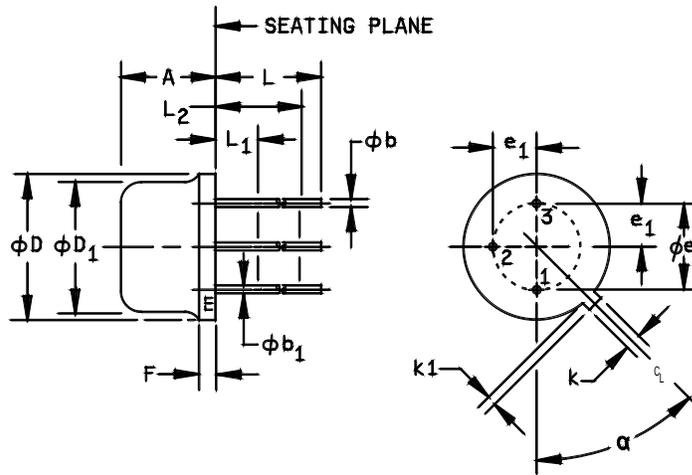

Symbol	Inches		Millimeters		Notes
	Min	Max	Min	Max	
A	0.115	0.150	2.92	3.81	
ϕb	0.016	0.019	0.41	0.48	1,4
ϕb_1	---	0.021	---	0.53	1,4
ϕD	0.209	0.230	5.31	5.84	
ϕD_1	0.178	0.195	4.52	4.95	
ϕe	0.100 T.P.		2.54 T.P.		2
e_1	0.050 T.P.		1.27 T.P.		2
F	---	0.030	---	0.76	
k	0.036	0.046	0.91	1.17	
k1	0.028	0.048	0.71	1.22	3
L	0.500	---	12.70	---	1
L1	---	0.050	---	1.27	1
L2	0.250	---	6.35	---	
α	45° T.P.				

NOTES:

1. (Three leads) ϕb applies between L_1 and L_2 . ϕb_1 applies between L_2 and 0.5 inch (12.70 mm) from seating plane. Diameter is uncontrolled in L_1 and beyond 0.5 inch (12.70 mm) from seating plane.
2. Leads having maximum diameter 0.019 inch (0.48 mm) measured in gauging plane 0.054 inch (1.4 mm) + 0.001 inch (0.03 mm) – 0.000 inch (0.00 mm) below the seating plane of the device are within 0.007 inch (0.18 mm) of their true positions relative to a maximum-width tab.
3. Measured from maximum diameter of the actual device.
4. All leads – increased maximum limit by 0.003 inch (0.08 mm) when hot solder dip finish is applied.
5. The U.S. government preferred system of measurement is the metric SI system. However, since this item was originally designed using inch-pound units of measurement, in the event of conflict between the metric and inch-pound units, the inch-pound units shall take precedence.

FIGURE 1. Case outline.

STANDARD MICROCIRCUIT DRAWING DEFENSE SUPPLY CENTER COLUMBUS COLUMBUS, OHIO 43218-3990	SIZE A		5962-86861
		REVISION LEVEL F	SHEET 5

Device type	01, 02, 03		
Case outlines	P	X	Y
Terminal number	Terminal symbol		
1	+V _{IN}	+V _{IN}	+V _{IN}
2	V _{OUT}	V _{OUT}	V _{OUT}
3	-V _{IN}	-V _{IN}	-V _{IN}
4	NC	---	---
5	NC	---	---
6	NC	---	---
7	NC	---	---
8	NC	---	---

NC = No connection

FIGURE 2. Terminal connections.

STANDARD MICROCIRCUIT DRAWING DEFENSE SUPPLY CENTER COLUMBUS COLUMBUS, OHIO 43218-3990	SIZE A		5962-86861
		REVISION LEVEL F	SHEET 6

3.5.1 Certification/compliance mark. A compliance indicator "C" shall be marked on all non-JAN devices built in compliance to MIL-PRF-38535, appendix A. The compliance indicator "C" shall be replaced with a "Q" or "QML" certification mark in accordance with MIL-PRF-38535 to identify when the QML flow option is used.

3.6 Certificate of compliance. A certificate of compliance shall be required from a manufacturer in order to be listed as an approved source of supply in MIL-HDBK-103 (see 6.6 herein). The certificate of compliance submitted to DSCC-VA prior to listing as an approved source of supply shall affirm that the manufacturer's product meets the requirements of MIL-PRF-38535, appendix A and the requirements herein.

3.7 Certificate of conformance. A certificate of conformance as required in MIL-PRF-38535, appendix A shall be provided with each lot of microcircuits delivered to this drawing.

3.8 Notification of change. Notification of change to DSCC-VA shall be required for any change that affects this drawing.

3.9 Verification and review. DSCC, DSCC's agent, and the acquiring activity retain the option to review the manufacturer's facility and applicable required documentation. Offshore documentation shall be made available onshore at the option of the reviewer.

4. VERIFICATION

4.1 Sampling and inspection. Sampling and inspection procedures shall be in accordance with MIL-PRF-38535, appendix A.

4.2 Screening. Screening shall be in accordance with method 5004 of MIL-STD-883, and shall be conducted on all devices prior to quality conformance inspection. The following additional criteria shall apply:

- a. Burn-in test, method 1015 of MIL-STD-883.
 - (1) Test condition A, B, C, or D. The test circuit shall be maintained by the manufacturer under document revision level control and shall be made available to the preparing or acquiring activity upon request. The test circuit shall specify the inputs, outputs, biases, and power dissipation, as applicable, in accordance with the intent specified in method 1015 of MIL-STD-883.
 - (2) $T_A = +125^\circ\text{C}$, minimum.
- b. Interim and final electrical test parameters shall be as specified in table II herein, except interim electrical parameter tests prior to burn-in are optional at the discretion of the manufacturer.
- c. Optional subgroup 12 is used for grading and part selection at $T_A = +25^\circ\text{C}$. It is not included in PDA.

4.3 Quality conformance inspection. Quality conformance inspection shall be in accordance with method 5005 of MIL-STD-883 including groups A, B, C, and D inspections. The following additional criteria shall apply.

4.3.1 Group A inspection.

- a. Tests shall be as specified in table II herein.
- b. Subgroups 4, 5, 6, 7, 8, 9, 10, and 11 in table I, method 5005 of MIL-STD-883 shall be omitted.
- c. Optional subgroup 12 is used for grading and part selection at $T_A = +25^\circ\text{C}$.

STANDARD MICROCIRCUIT DRAWING DEFENSE SUPPLY CENTER COLUMBUS COLUMBUS, OHIO 43218-3990	SIZE A		5962-86861
		REVISION LEVEL F	SHEET 7

TABLE II. Electrical test requirements.

MIL-STD-883 test requirements	Subgroups (in accordance with MIL-STD-883, method 5005, table I)
Interim electrical parameters (method 5004)	1
Final electrical test parameters (method 5004)	1*, 2, 3, 12
Group A test requirements (method 5005)	1, 2, 3, 12
Groups C and D end-point electrical parameters (method 5005)	1

* PDA applies to subgroup 1.

4.3.2 Groups C and D inspections.

- a. End-point electrical parameters shall be as specified in table II herein.
- b. Steady-state life test conditions, method 1005 of MIL-STD-883.
 - (1) Test condition A, B, C, or D. The test circuit shall be maintained by the manufacturer under document revision level control and shall be made available to the preparing or acquiring activity upon request. The test circuit shall specify the inputs, outputs, biases, and power dissipation, as applicable, in accordance with the intent specified in method 1005 of MIL-STD-883.
 - (2) $T_A = +125^{\circ}\text{C}$, minimum.
 - (3) Test duration: 1,000 hours, except as permitted by method 1005 of MIL-STD-883.

5. PACKAGING

5.1 Packaging requirements. The requirements for packaging shall be in accordance with MIL-PRF-38535, appendix A.

6. NOTES

6.1 Intended use. Microcircuits conforming to this drawing are intended for use for Government microcircuit applications (original equipment), design applications, and logistics purposes.

6.2 Replaceability. Microcircuits covered by this drawing will replace the same generic device covered by a contractor-prepared specification or drawing.

STANDARD MICROCIRCUIT DRAWING DEFENSE SUPPLY CENTER COLUMBUS COLUMBUS, OHIO 43218-3990	SIZE A		5962-86861
		REVISION LEVEL F	SHEET 8

6.3 Configuration control of SMD's. All proposed changes to existing SMD's will be coordinated with the users of record for the individual documents. This coordination will be accomplished using DD Form 1692, Engineering Change Proposal.

6.4 Record of users. Military and industrial users shall inform Defense Supply Center Columbus (DSCC) when a system application requires configuration control and the applicable SMD. DSCC will maintain a record of users and this list will be used for coordination and distribution of changes to the drawings. Users of drawings covering microelectronics devices (FSC 5962) should contact DSCC-VA, telephone (614) 692-0544.

6.5 Comments. Comments on this drawing should be directed to DSCC-VA, Columbus, Ohio 43218-3990, or telephone (614) 692-0547

6.6 Approved sources of supply. Approved sources of supply are listed in MIL-HDBK-103. The vendors listed in MIL-HDBK-103 have agreed to this drawing and a certificate of compliance (see 3.6 herein) has been submitted to and accepted by DSCC-VA.

STANDARD MICROCIRCUIT DRAWING DEFENSE SUPPLY CENTER COLUMBUS COLUMBUS, OHIO 43218-3990	SIZE A		5962-86861
		REVISION LEVEL F	SHEET 9

STANDARD MICROCIRCUIT DRAWING BULLETIN

DATE: 09-01-13

Approved sources of supply for SMD 5962-86861 are listed below for immediate acquisition information only and shall be added to MIL-HDBK-103 and QML-38535 during the next revision. MIL-HDBK-103 and QML-38535 will be revised to include the addition or deletion of sources. The vendors listed below have agreed to this drawing and a certificate of compliance has been submitted to and accepted by DSCC-VA. This information bulletin is superseded by the next dated revision of MIL-HDBK-103 and QML-38535. DSCC maintains an online database of all current sources of supply at <http://www.dscclia.mil/Programs/Smcr/>.

Standard microcircuit drawing PIN <u>1/</u>	Vendor CAGE number	Vendor similar PIN <u>2/</u>
5962-8686101PA	34333	SG1503Y/883B
	60264	MTLT580SQD8
5962-8686101XA	24355	AD580SH/883B
	60264	MTLT580SQH
	<u>3/</u>	SG1503T/883B
	<u>3/</u>	LT580SH/883
5962-8686101XC	<u>3/</u>	MX580SH/883B
5962-8686101YA	34333	SG1503T/883B
5962-8686102PA	<u>3/</u>	SG1503AY/883B
	60264	MTLT580TQD8
5962-8686102XA	24355	AD580TH/883B
	60264	MTLT580TQH
	<u>3/</u>	LT580TH/883
5962-8686102XC	<u>3/</u>	MX580TH/883B
5962-8686103XA	24355	AD580UH/883B
	60264	MTLT580UQH
	<u>3/</u>	LT580UH/883
5962-8686103XC	<u>3/</u>	MX580UH/883B
5962-8686103PA	60264	MTLT580UQD8

- 1/ The lead finish shown for each PIN representing a hermetic package is the most readily available from the manufacturer listed for that part. If the desired lead finish is not listed contact the vendor to determine its availability.
- 2/ Caution. Do not use this number for item acquisition. Items acquired to this number may not satisfy the performance requirements of this drawing.
- 3/ Not available from an approved source of supply.

STANDARD MICROCIRCUIT DRAWING BULLETIN – Continued.

<u>Vendor CAGE number</u>	<u>Vendor name and address</u>
60264	Minco Technology Labs, Inc. 1805 Rutherford Lane Austin, TX 78754-5101
24355	Analog Devices Route 1 Industrial Park P.O. Box 9106 Norwood, MA 02062 Point of contact: 804 Woburn Street Wilmington, MA 01887-3462
34333	Microsemi Analog Mixed Signal Group 11861 Western Avenue Garden Grove, CA 92841-2119

The information contained herein is disseminated for convenience only and the Government assumes no liability whatsoever for any inaccuracies in the information bulletin.