



MIC4426/4427/4428

Dual High Speed MOSFET Driver

Bipolar/CMOS/DMOS Process

General Description

The MIC4426/4427/4428 family of buffer/drivers are built using a new, highly reliable BiCMOS/DMOS process. They are improved versions of the MIC426/427/428 family of buffer/drivers (with which they are pin compatible) and are capable of giving reliable service in far more demanding electrical environments: they will not latch under any conditions within their power and voltage ratings. They are not subject to damage when up to 5V of noise spiking, of either polarity, occurs on the ground pin. They can accept, without either damage or logic upset, up to half an amp of reverse current (of either polarity) being forced back into their outputs. All terminals are fully protected against up to 2kV of electrostatic discharge.

As a result, the MIC4426/27/28 series drivers are much easier to use, more flexible in operation, and much more forgiving than any other driver, CMOS or bipolar, currently available. Because they are fabricated in BiCMOS/DMOS, they dissipate a minimum of power, and provide rail-to-rail voltage swings to better insure the logic state of any load they are driving.

Although primarily intended for driving power MOSFETs, the 4426/4427/4428 series drivers are equally well suited to driving any other load (capacitive, resistive, or inductive) which requires a low-impedance driver capable of high peak currents and fast switching times. For example, heavily loaded clock lines, coaxial cables, or piezoelectric transducers all can be driven from the MIC4426/27/28. The only known limitation on loading is that total power dissipated in the driver must be kept within the maximum power dissipation limits of the package.

Features

- Built using reliable, low power Bipolar/CMOS/DMOS processes
- Latch-Up Protected: Withstands >500mA Reverse Current
- Logic Input Will Withstand Negative Swing Up to 5V
- ESD Protected2kV
- High Peak Output Current 1.5A Peak
- Wide Operating Range 4.5V to 18V
- High Capacitive Load
- Drive Capability 1000pF in 25nS
- Short Delay Times <40nS typ.
- Consistent Delay Times with Changes in Supply Voltage
- Matched Rise and Fall Times
- Logic High Input for Any Voltage From 2.4V to V_s^-
- Logic Input Threshold Independent of Supply Voltage
- Low Supply Current
 - 4 mA with Logic 1 Input
 - 400 μ A with Logic 0 Input
- Low Output Impedance 7 Ω
- Output Voltage Swing to Within 25mV of Ground or V_s^+
- Pin-Out Same as MIC426/427/428
- Available in Inverting, Non-Inverting, and Differential Configurations
- MIL-STD-883 Method 5004/5005 version available

2

As MOSFET drivers, the MIC4426/27/28 can easily switch 1000pF gate capacitances in under 30nS, and provide low enough impedances in both the ON and OFF states to assure that a MOSFET's intended state will not be affected even by large transients.

Functional Diagram

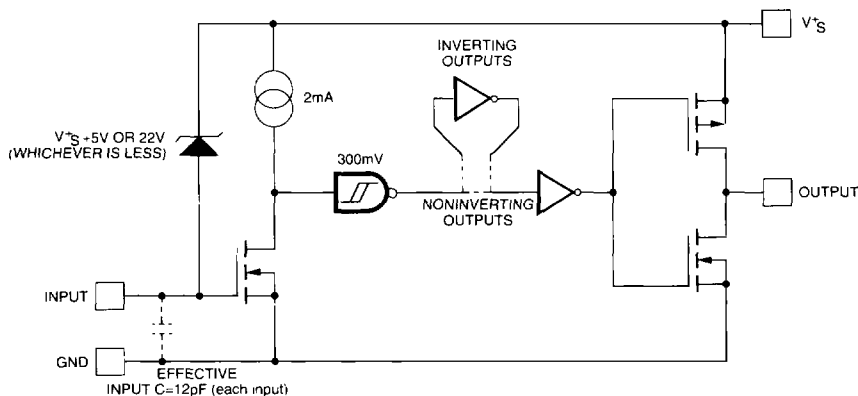

Ordering Information

Part Number	Temperature Range	Package	Configuration
MIC4426CM MIC4426BM	0°C to +70°C -40°C to +85°C	8-Pin SOIC	Dual Inverting
MIC4426CN MIC4426BN	0°C to +70°C -40°C to +85°C	8-Pin Plastic DIP	Dual Inverting
MIC4426BJ MIC4426AJ MIC4426AJB*	-40°C to +85°C -55°C to +125°C -55°C to +125°C	8-Pin CerDIP	Dual Inverting
MIC4427CM MIC4427BM	0°C to +70°C -40°C to +85°C	8-Pin SOIC	Dual Non-Inverting
MIC4427CN MIC4427BN	0°C to +70°C -40°C to +85°C	8-Pin Plastic DIP	Dual Non-Inverting
MIC4427BJ MIC4427AJ MIC4427AJB*	-40°C to +85°C -55°C to +125°C -55°C to +125°C	8-Pin CerDIP	Dual Non-Inverting
MIC4428CM MIC4428BM	0°C to +70°C -40°C to +85°C	8-Pin SOIC	Inverting + Non-Inverting
MIC4428CN MIC4428BN	0°C to +70°C -40°C to +85°C	8-Pin Plastic DIP	Inverting + Non-Inverting
MIC4428BJ MIC4428AJ MIC4428AJB*	-40°C to +85°C -55°C to +125°C -55°C to +125°C	8-Pin CerDIP	Inverting + Non-Inverting
MIC4426CY MIC4426AY MIC4427CY MIC4427AY MIC4428CY MIC4428AY	0°C to +70°C -55°C to +125°C 0°C to +70°C -55°C to +125°C 0°C to +70°C -55°C to +125°C	Die Die Die Die Die Die	Dual Inverting Dual Inverting Dual Non-Inverting Dual Non-Inverting Inverting + Non-Inverting Inverting + Non-Inverting

* AJB indicates units screened to MIL-STD 883, Method 5004, condition B, and burned-in for 1-week.

Absolute Maximum Ratings (Notes 1 and 2)

If Military/Aerospace specified devices are required, contact Micrel for availability and specifications.

Supply Voltage	22 V
Maximum Chip Temperature	150°C
Storage Temperature Range	-65°C to 150°C
Lead Temperature (10 sec.)	300°C
Package Thermal Resistance	
CERDIP R _{θJ-A}	150°C/W
CERDIP R _{θJ-C}	50°C/W
PDIP R _{θJ-A}	125°C/W
PDIP R _{θJ-C}	42°C/W
SOIC R _{θJ-A}	250°C/W
SOIC R _{θJ-C}	75°C/W

Operating Temperature Range

C Version	0°C to +70°C
B Version	-40°C to +85°C
A Version	-55°C to +125°C

Package Power Dissipation

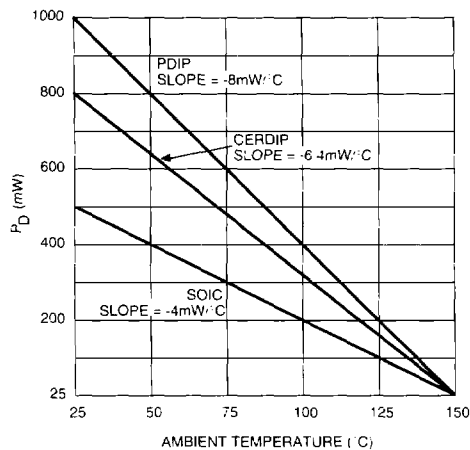

MIC4426/4427/4428 Electrical Characteristics:Specifications measured at $T_A = 25^\circ\text{C}$ with $4.5\text{V} \leq V_S \leq 18\text{V}$ unless otherwise specified.

Symbol	Parameter	Conditions	Min	Typ	Max	Units
INPUT						
V_{IH}	Logic 1 Input Voltage		2.4			V
V_{IL}	Logic 0 Input Voltage				0.8	V
I_{IN}	Input Current	$0 \leq V_{IN} \leq V_S$	-1		1	μA
OUTPUT						
V_{OH}	High Output Voltage		$V_S - 0.025$			V
V_{OL}	Low Output Voltage				0.025	V
R_O	Output Resistance	$I_{OUT} = 10\text{mA}$, $V_S = 18\text{V}$		7	10	Ω
I_{PK}	Peak Output Current			1.5		A
I	Latch-Up Protection Withstand Reverse Current		>500			mA
SWITCHING TIME						
T_R	Rise Time	Test Figure 1		25	30	nS
T_F	Fall Time	Test Figure 1		25	30	nS
T_{D1}	Delay Time	Test Figure 1			30	nS
T_{D2}	Delay Time	Test Figure 1			50	nS
POWER SUPPLY						
I_S	Power Supply Current	$V_{IN} = 3.0\text{V}$ (Both Inputs)			4.5	mA
I_S	Power Supply Current	$V_{IN} = 0.0\text{V}$ (Both Inputs)			0.4	mA

2

MIC4426/4427/4428 Electrical Characteristics:Specifications measured over operating temperature range with $4.5\text{V} \leq V_S \leq 18\text{V}$ unless otherwise specified.

Symbol	Parameter	Conditions	Min	Typ	Max	Units
INPUT						
V_{IH}	Logic 1 Input Voltage		2.4			V
V_{IL}	Logic 0 Input Voltage				0.8	V
I_{IN}	Input Current	$0 \leq V_{IN} \leq V_S$	-1		1	μA
OUTPUT						
V_{OH}	High Output Voltage		$V_S - 0.025$			V
V_{OL}	Low Output Voltage				0.025	V
R_O	Output Resistance	$I_{OUT} = 10\text{mA}$, $V_S = 18\text{V}$		9	12	Ω

MIC4426/4427/4428 Electrical Characteristics:

Specifications measured over operating temperature range with $4.5\text{ V} \leq V_S \leq 18\text{ V}$ unless otherwise specified.

Symbol	Parameter	Conditions	Min	Typ	Max	Units
OUTPUT						
I_{PK}	Peak Output Current			1.5		A
I	Latch-Up Protection Withstand Reverse Current		>500			mA
SWITCHING TIME						
T_R	Rise Time	Test Figure 1			40	nS
T_F	Fall Time	Test Figure 1			40	nS
T_{D1}	Delay Time	Test Figure 1			40	nS
T_{D2}	Delay Time	Test Figure 1			60	nS
POWER SUPPLY						
I_S	Power Supply Current	$V_{IN} = 3.0\text{ V}$ (Both Inputs)			8	mA
I_S	Power Supply Current	$V_{IN} = 0.0\text{ V}$ (Both Inputs)			0.6	mA

Note 1: Functional operation above the absolute maximum stress ratings is not implied.

Note 2: Static Sensitive device (above 2kV). Store only in conductive containers. Handling personnel and equipment should be grounded to prevent static damage.

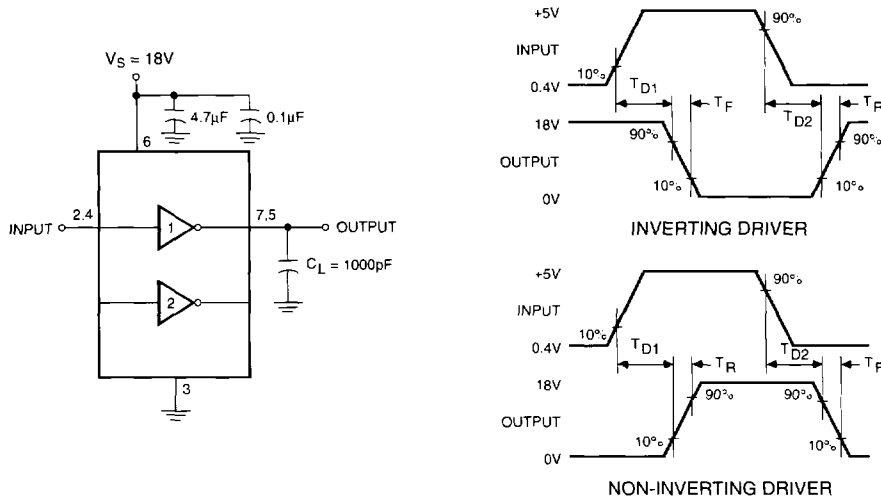
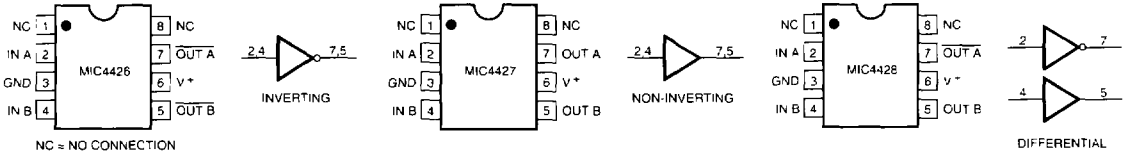
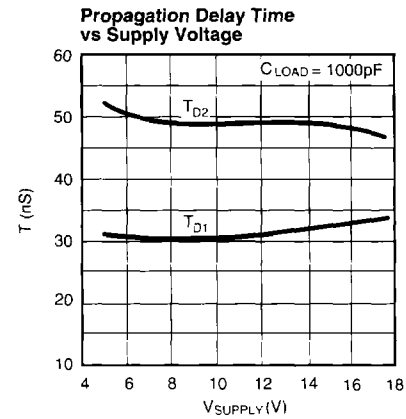
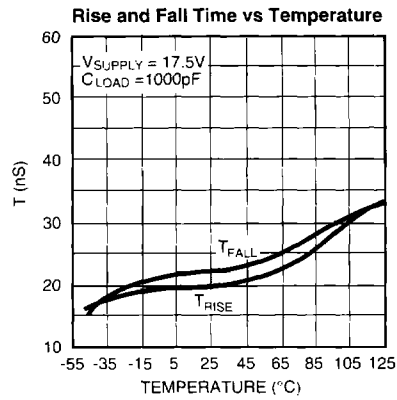
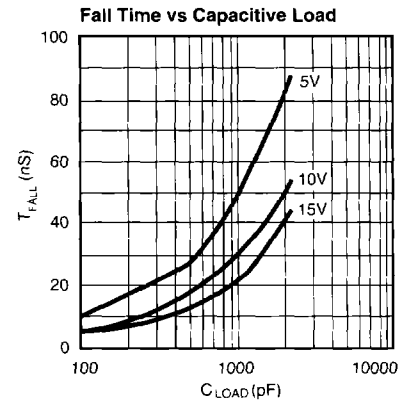
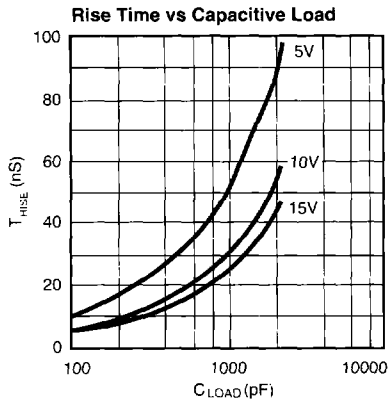
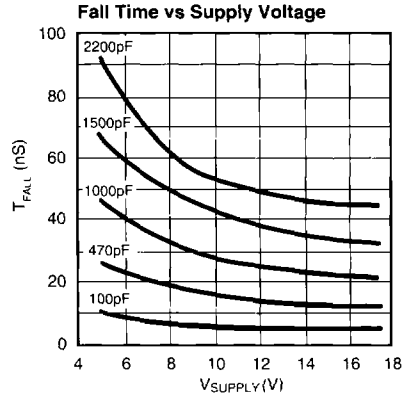
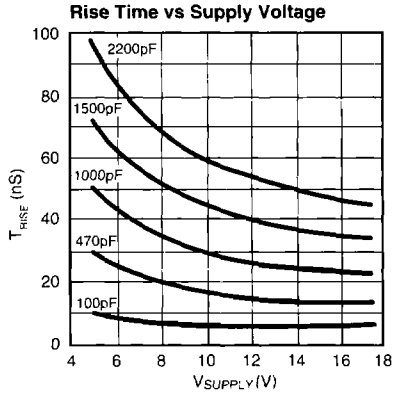

Figure 1. Switching Time Test Circuit

Pin Configuration



Typical Characteristic Curves



2

Typical Characteristic Curves (Continued)

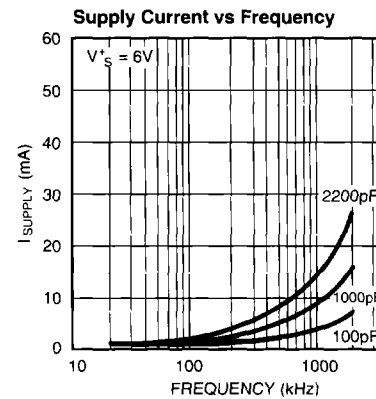
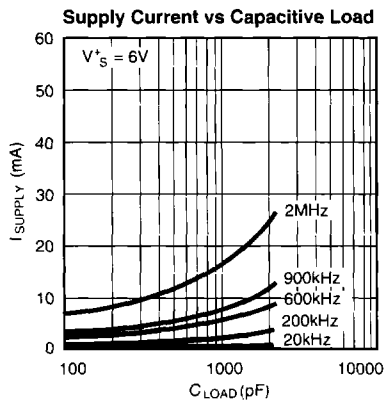
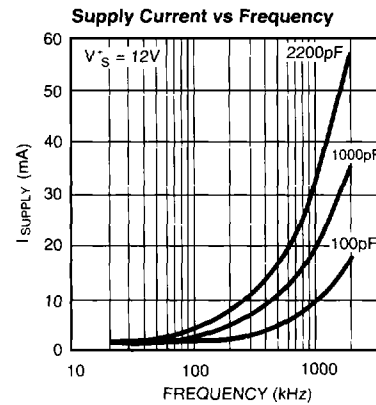
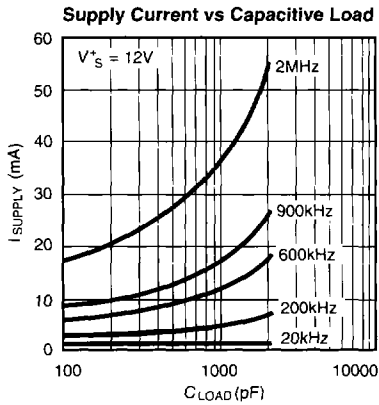
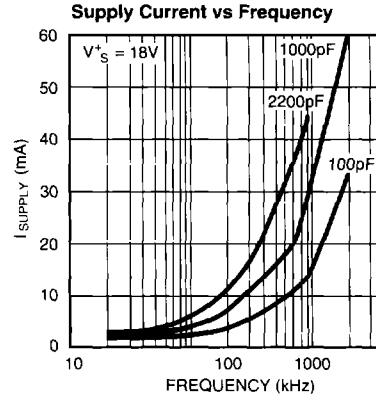
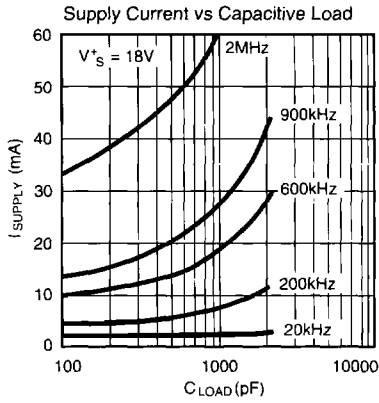

Typical Characteristic Curves (Continued)

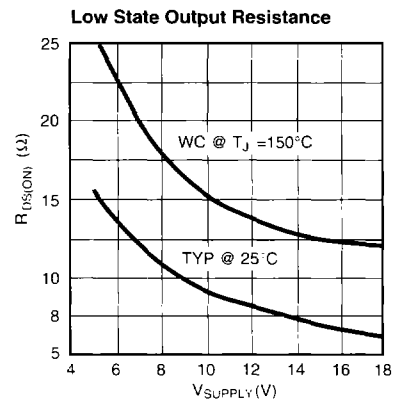
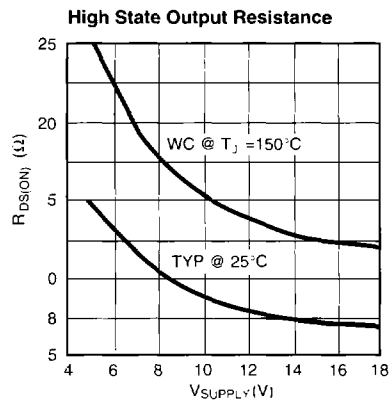
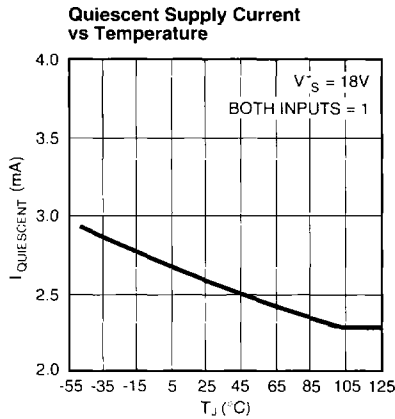
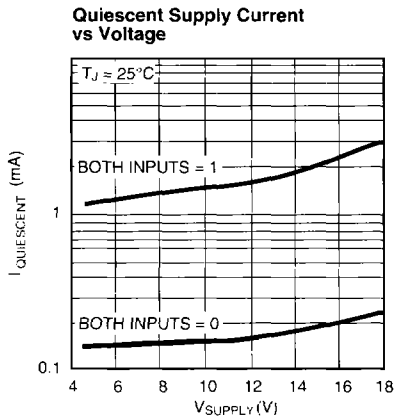
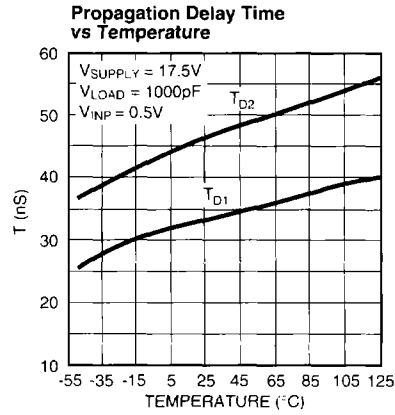
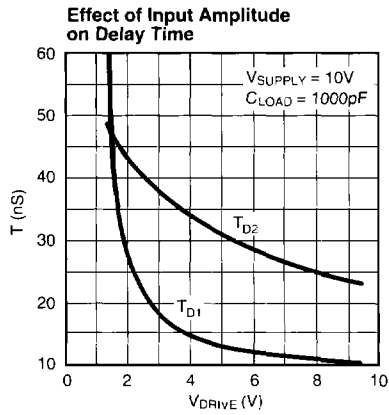

2

Crossover Energy Loss

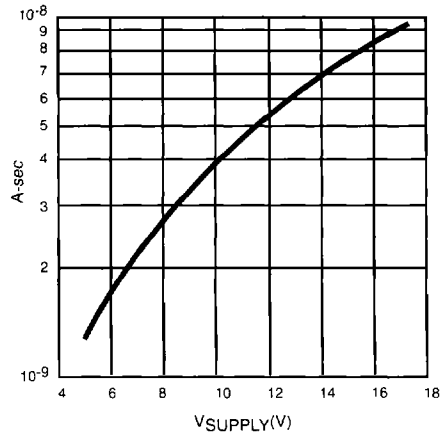

Note 1: The values on this graph represent the loss seen by both drivers in a package during one complete cycle. For a single driver divide the stated values by 2. For a single transition of a single driver, divide the stated value by 4.