

*New
KIN
03000*

Kingbright Electronic Co., Ltd.



Mail Address : P. O. Box 81-153 Taipei, Taiwan
Telex No. : 22249 TWNKIN

Cable Address: "TWNKIN" Taipei
Telephones : 715-2848 • 713-0682

2.5 x 5mm RECTANGULAR LED LAMP

L-511

Unit: mm
Tolerance: ±0.2

✓ New

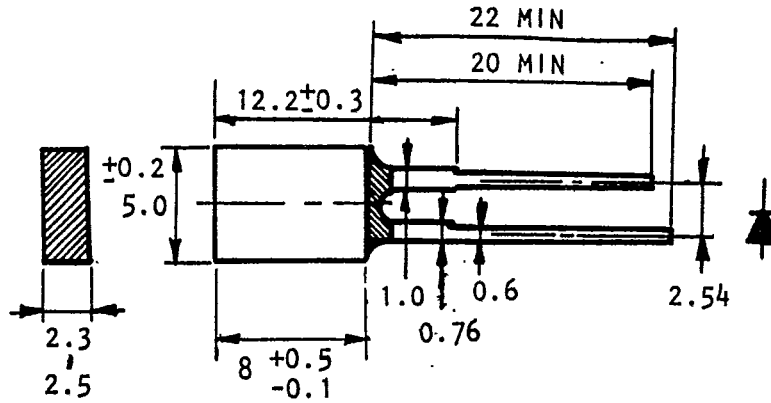

SELECTION GUIDE

PART NO.	SOURCE (DICE)	LENSE TYPE (RESIN)	AXIAL LUMINOUS INTENSITY IN MCD @ 20mA		VIEWING ANGLE
			MIN	TYP	
✓ L-511RDT	RED (GaAsP)	Red Top Diffused	0.5	2.0	120°
✓ L-511HDT	HIGH EFFICIENCY RED (GaP)	Red Top Diffused	0.5	2.2	120°
✓ L-511IDT	HIGH INTENSITY RED (GaAsP/GaP)	Red Top Diffused	2.0	4.0	120°
✓ L-511GDT	GREEN (GaP)	Green Top Diff.	1.0	3.5	120°
✓ L-511YDT	YELLOW (GaAsP/GaP)	Yellow Top Diff.	4.0	6.0	120°
✓ L-511EDT	ORANGE (GaAsP/GaP)	Orange Top Diff.	2.0	4.0	120°
✓ L-511ADT	AMBER (GaAsP/GaP)	Amber Top Diff.	4.0	6.0	120°