

# Dual and single low noise op amp

# NE5533/5533A/ NE/SA/SE5534/5534A

## DESCRIPTION

The 5533/5534 are dual and single high-performance low noise operational amplifiers. Compared to other operational amplifiers, such as TL083, they show better noise performance, improved output drive capability and considerably higher small-signal and power bandwidths.

This makes the devices especially suitable for application in high quality and professional audio equipment, in instrumentation and control circuits and telephone channel amplifiers. The op amps are internally compensated for gain equal to, or higher than, three. The frequency response can be optimized with an external compensation capacitor for various applications (unity gain amplifier, capacitive load, slew rate, low overshoot, etc.) If very low noise is of prime importance, it is recommended that the 5533A/5534A version be used which has guaranteed noise specifications.

## FEATURES

- Small-signal bandwidth: 10MHz
- Output drive capability: 600Ω, 10VRMS at  $V_S = \pm 18V$
- Input noise voltage:  $4nV/\sqrt{Hz}$
- DC voltage gain: 100000
- AC voltage gain: 6000 at 10kHz
- Power bandwidth: 200kHz
- Slew rate: 13V/μs
- Large supply voltage range: ±3 to ±20V
- 5534 MIL-STD processing available

## APPLICATIONS

- Audio equipment
- Instrumentation and control circuits
- Telephone channel amplifiers
- Medical equipment

## ORDERING INFORMATION

DESCRIPTION	TEMPERATURE RANGE	ORDER CODE
14-Pin Plastic DIP	0 to +70°C	NE5533N
16-Pin Plastic SO package	0 to +70°C	NE5533AD
14-Pin Plastic DIP	0 to +70°C	NE5533AN
16-Pin Plastic SO package	0 to +70°C	NE5533D
8-Pin Plastic SO package	0 to +70°C	NE5534D
8-Pin Hermetic Cerdip	0 to +70°C	NE5534FE
8-Pin Plastic DIP	0 to +70°C	NE5534N
8-Pin Plastic SO package	0 to +70°C	NE5534AD
8-Pin Hermetic Cerdip	0 to +70°C	NE5534AF
8-Pin Plastic DIP	0 to +70°C	NE5534AN
8-Pin Plastic DIP	-40°C to +85°C	SA5534N
8-Pin Plastic SO package	-40°C to +85°C	SA5534AD
8-Pin Hermetic Cerdip	-55°C to +125°C	SE5534AF
8-Pin Plastic DIP	-55°C to +125°C	SE5534N
8-Pin Hermetic Cerdip	-55°C to +125°C	SE5534AF
8-Pin Plastic DIP	-55°C to +125°C	SE5534AN

## PIN CONFIGURATIONS

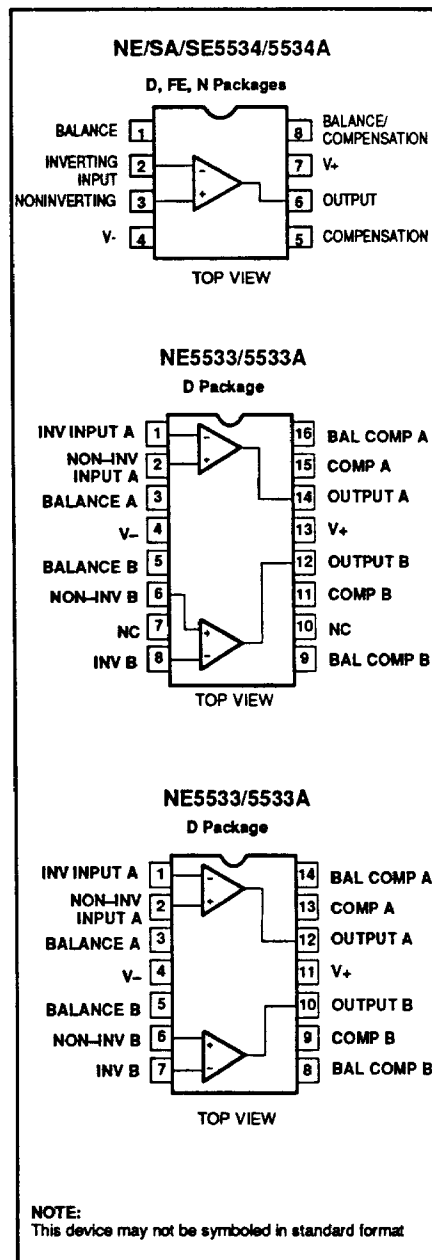

## Dual and single low noise op amp

NE5533/5533A/  
NE/SA/SE5534/5534A

## ABSOLUTE MAXIMUM RATINGS

SYMBOL	PARAMETER	RATING	UNIT
$V_S$	Supply voltage	$\pm 22$	V
$V_{IN}$	Input voltage	$\pm V$ supply	V
$V_{DIFF}$	Differential input voltage <sup>1</sup>	$\pm 0.5$	V
$T_A$	Operating temperature range		
	SE	-55 to +125	°C
	SA	-40 to +85	°C
	NE	0 to +70	°C
$T_{STG}$	Storage temperature range	-65 to +150	°C
$T_J$	Junction temperature	150	°C
$P_D$	Power dissipation at 25°C <sup>2</sup>		
	5533D	1350	mW
	5533N	1500	mW
	5534D	750	mW
	5534FE	800	mW
	5534N	1150	mW
	Output short-circuit duration <sup>3</sup>	Indefinite	
$T_{SOLD}$	Lead soldering temperature (10sec max)	300	°C

## NOTES:

- Diodes protect the inputs against over voltage. Therefore, unless current-limiting resistors are used, large currents will flow if the differential input voltage exceeds 0.6V. Maximum current should be limited to  $\pm 10$ mA.
- For operation at elevated temperature, derate packages based on the following junction-to-ambient thermal resistance:
  - 8-pin ceramic DIP 150°C/W
  - 8-pin plastic DIP 105°C/W
  - 8-pin plastic SO 160°C/W
  - 14-pin plastic DIP 80°C/W
  - 16-pin plastic SO 90°C/W
- Output may be shorted to ground at  $V_S = \pm 15$ V,  $T_A = 25^\circ\text{C}$ . Temperature and/or supply voltages must be limited to ensure dissipation rating is not exceeded.

## Dual and single low noise op amp

NE5533/5533A/  
NE/SA/SE5534/5534A

## DC ELECTRICAL CHARACTERISTICS

 $T_A=25^\circ\text{C}$ ,  $V_S=\pm 15\text{V}$ , unless otherwise specified. 1, 2, 3

SYMBOL	PARAMETER	TEST CONDITIONS	SE5534/5534A			NE5533/5533A NE/SA5534/5534A			UNIT
			Min	Typ	Max	Min	Typ	Max	
$V_{OS}$	Offset voltage	Over temperature		0.5	2		0.5	4	mV
$\Delta V_{OS}/\Delta T$				5	3		5	5	$\mu\text{V}/^\circ\text{C}$
$I_{OS}$	Offset current	Over temperature		10	200		20	300	nA
$\Delta I_{OS}/\Delta T$				200	500		200	400	$\text{pA}/^\circ\text{C}$
$I_B$	Input current	Over temperature		400	800		500	1500	nA
$\Delta I_B/\Delta T$				5	1500		5	2000	$\text{nA}/^\circ\text{C}$
$I_{CC}$	Supply current per op amp	Over temperature		4	6.5		4	8	mA
				9			10	10	mA
$V_{CM}$	Common mode input range		$\pm 12$	$\pm 13$		$\pm 12$	$\pm 13$		V
CMRR	Common mode rejection ratio		80	100		70	100		dB
PSRR	Power supply rejection ratio			10	50		10	100	$\mu\text{V}/\text{V}$
$A_{VOL}$	Large-signal voltage gain	$R_L \geq 600\Omega$ , $V_O = \pm 10\text{V}$ Over temperature	50	100		25	100		V/mV
			25			15			V/mV
$V_{OUT}$	Output swing	$R_L \geq 600\Omega$	$\pm 12$	$\pm 13$		$\pm 12$	$\pm 13$		V
		Over temperature	$\pm 10$	$\pm 12$		$\pm 10$	$\pm 12$		V
		$R_L \geq 600\Omega$ , $V_S = \pm 18\text{V}$	$\pm 15$	$\pm 16$		$\pm 15$	$\pm 16$		V
		$R_L \geq 2\text{k}\Omega$	$\pm 13$	$\pm 13.5$		$\pm 13$	$\pm 13.5$		V
		Over temperature	$\pm 12$	$\pm 12.5$		$\pm 12$	$\pm 12.5$		V
$R_{IN}$	Input resistance		50	100		30	100		k $\Omega$
$I_{SC}$	Output short circuit current			38			38		mA

## NOTES:

- For NE5533/5533A/5534/5534A,  $T_{MIN} = 0^\circ\text{C}$ ,  $T_{MAX} = 70^\circ\text{C}$
- For SE5534/5534A,  $T_{MIN} = -55^\circ\text{C}$ ,  $T_{MAX} = +125^\circ\text{C}$
- For SA5534/5534A,  $T_{MIN} = -40^\circ\text{C}$ ,  $T_{MAX} = +125^\circ\text{C}$

# Dual and single low noise op amp

# NE5533/5533A/ NE/SA/SE5534/5534A

## AC ELECTRICAL CHARACTERISTICS

T<sub>A</sub>=25°C, V<sub>S</sub>=±15V, unless otherwise specified.

SYMBOL	PARAMETER	TEST CONDITIONS	SE5534/5534A			NE5533/5533A NESA5534/5534A			UNIT
			Min	Typ	Max	Min	Typ	Max	
R <sub>OUT</sub>	Output resistance	A <sub>V</sub> =30dB closed-loop f=10kHz, R <sub>L</sub> =600Ω, C <sub>C</sub> =22pF		0.3			0.3		Ω
	Transient response	Voltage-follower, V <sub>IN</sub> =50mV R <sub>L</sub> =600Ω, C <sub>C</sub> =22pF, C <sub>L</sub> =100pF							
t <sub>R</sub>	Rise time			20			20		ns
	Overshoot			20			20		%
	Transient response	V <sub>IN</sub> =50mV, R <sub>L</sub> =600Ω C <sub>C</sub> =47pF, C <sub>L</sub> =500pF							
t <sub>R</sub>	Rise time			50			50		ns
	Overshoot			35			35		%
A <sub>V</sub>	Gain	f=10kHz, C <sub>C</sub> =0		6			6		V/mV
		f=10kHz, C <sub>C</sub> =22pF		2.2			2.2		V/mV
GBW	Gain bandwidth product	C <sub>C</sub> =22pF, C <sub>L</sub> =100pF		10			10		MHz
SR	Slew rate	C <sub>C</sub> =0		13			13		V/μs
		C <sub>C</sub> =22pF		6			6		V/μs
	Power bandwidth	V <sub>OUT</sub> =±10V, C <sub>C</sub> =0		200			200		kHz
		V <sub>OUT</sub> =±10V, C <sub>C</sub> =22pF		95			95		kHz
		V <sub>OUT</sub> =±14V, R <sub>L</sub> =600Ω C <sub>C</sub> =22pF, V <sub>CC</sub> =±18V		70			70		kHz

## ELECTRICAL CHARACTERISTICS

T<sub>A</sub>=25°C, V<sub>S</sub> = 15V, unless otherwise specified.

SYMBOL	PARAMETER	TEST CONDITIONS	5533/5534			5533A/5534A			UNIT
			Min	Typ	Max	Min	Typ	Max	
V <sub>NOISE</sub>	Input noise voltage	f <sub>O</sub> =30Hz		7			5.5	7	nV/√Hz
		f <sub>O</sub> =1kHz		4			3.5	4.5	nV/√Hz
I <sub>NOISE</sub>	Input noise current	f <sub>O</sub> =30Hz		2.5			1.5		pA/√Hz
		f <sub>O</sub> =1kHz		0.6			0.4		pA/√Hz
	Broadband noise figure	f=10Hz-20kHz, R <sub>S</sub> =5kΩ					0.9		dB
	Channel separation	f=1kHz, R <sub>S</sub> =5kΩ		110			110		dB

# Dual and single low noise op amp

NE5533/5533A/  
NE/SA/SE5534/5534A

## EQUIVALENT SCHEMATIC

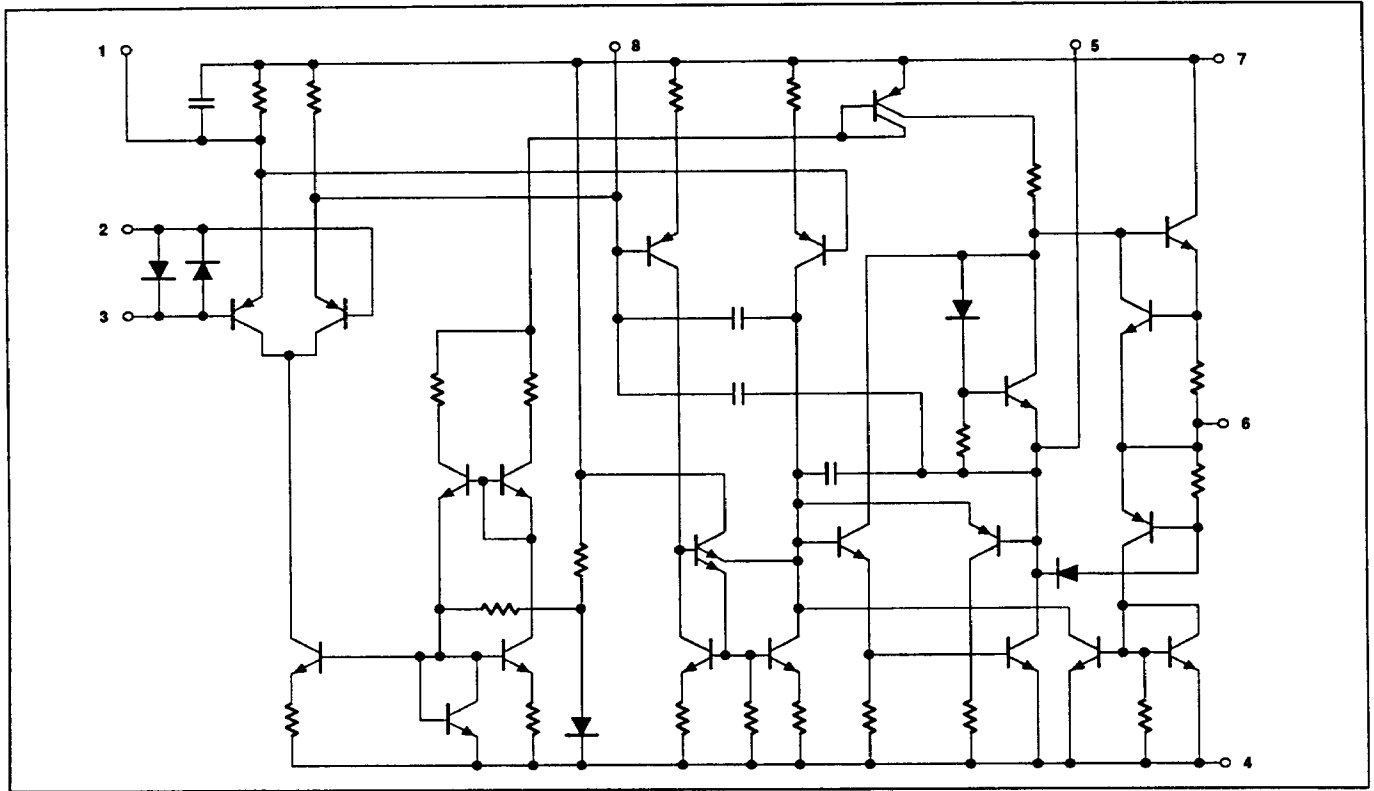

# Dual and single low noise op amp

# NE5533/5533A/ NE/SA/SE5534/5534A

## TYPICAL PERFORMANCE CHARACTERISTICS

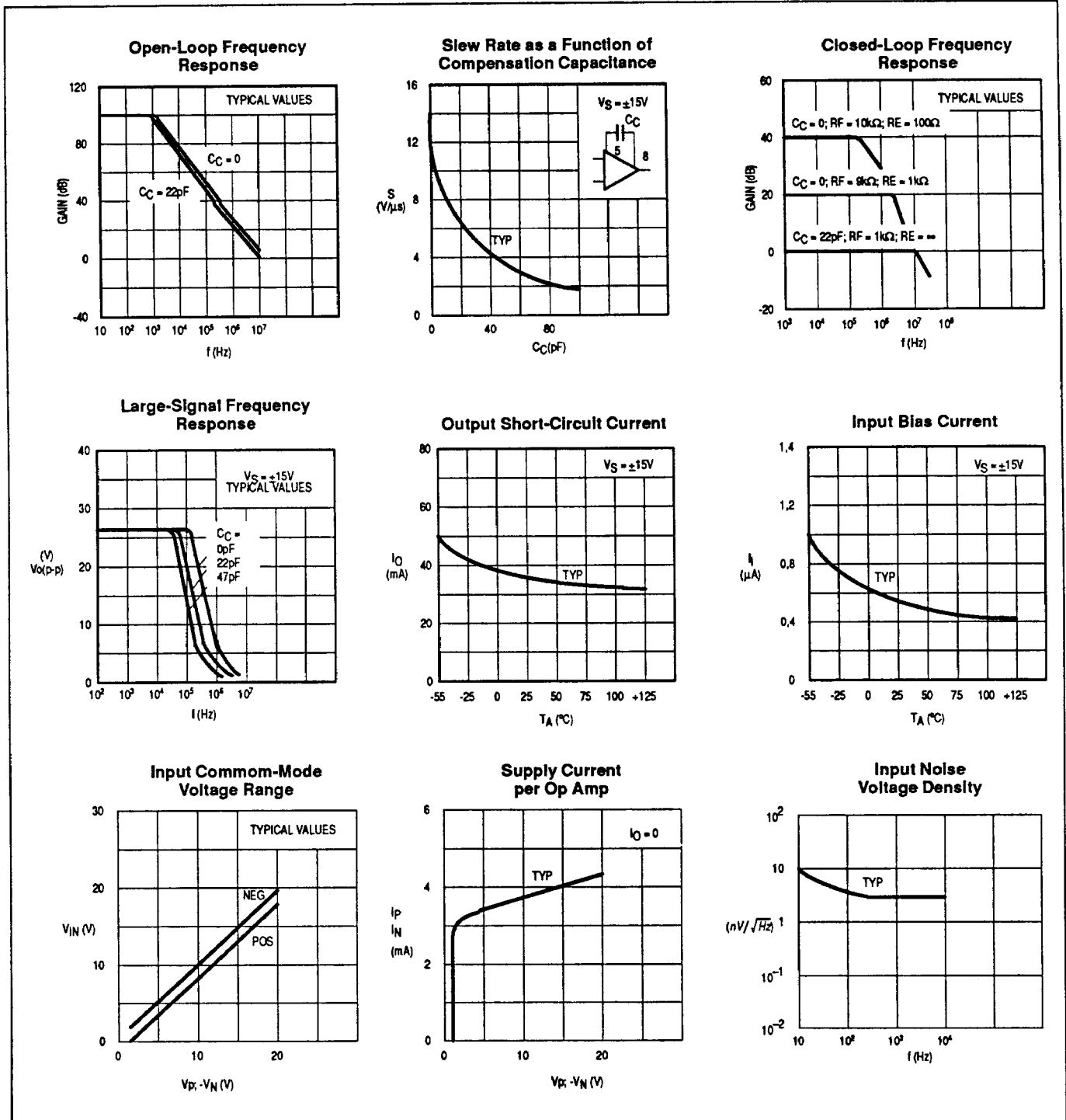

Dual and single low noise op amp

NE5533/5533A/  
NE/SA/SE5534/5534A

TYPICAL PERFORMANCE CHARACTERISTICS (Continued)

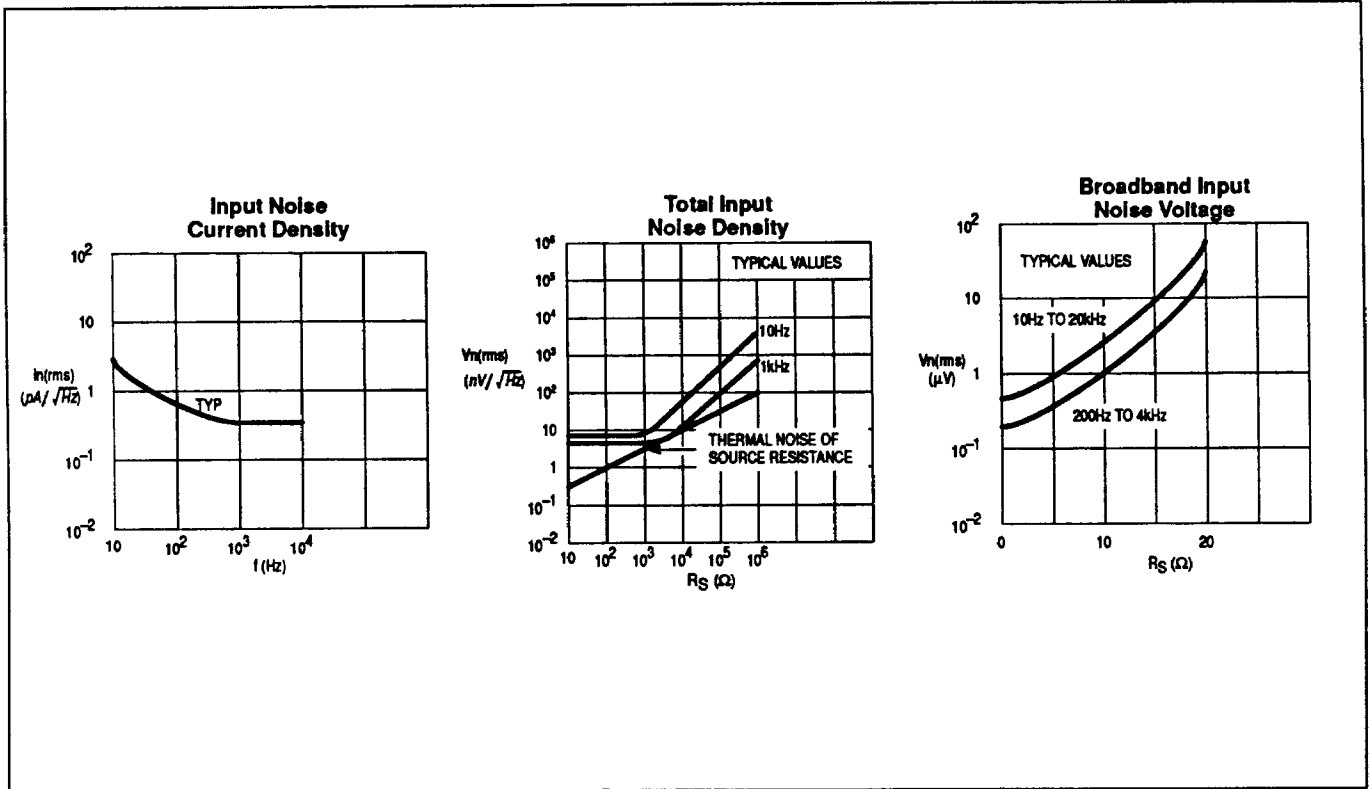

# Dual and single low noise op amp

NE5533/5533A/  
NE/SA/SE5534/5534A

## TEST LOAD CIRCUITS

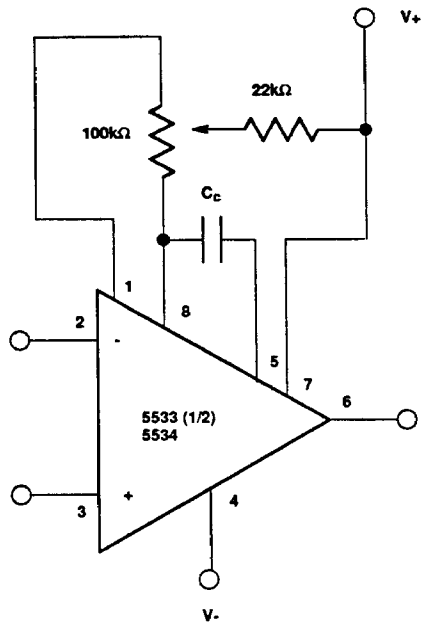

Frequency Compensation and Offset Voltage Adjustment Circuit

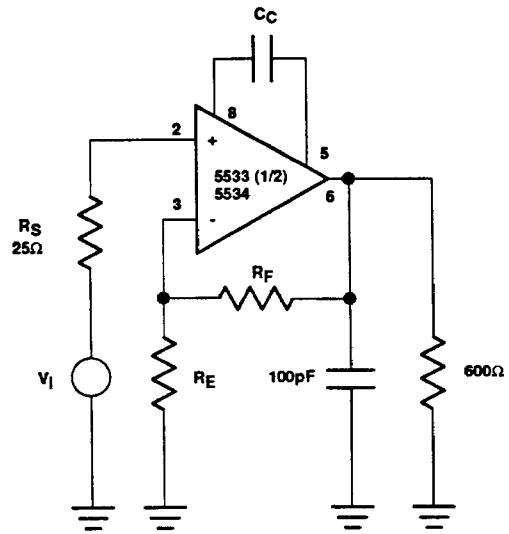

Closed-Loop Frequency Response



# Dual and single low noise op amp

NE5533/5533A/  
NE/SA/SE5534/5534A

## NOISE TEST BLOCK DIAGRAM

