

DRAWING FOR REFERENCE: This is subject to change without notice
08/11/2012

TO

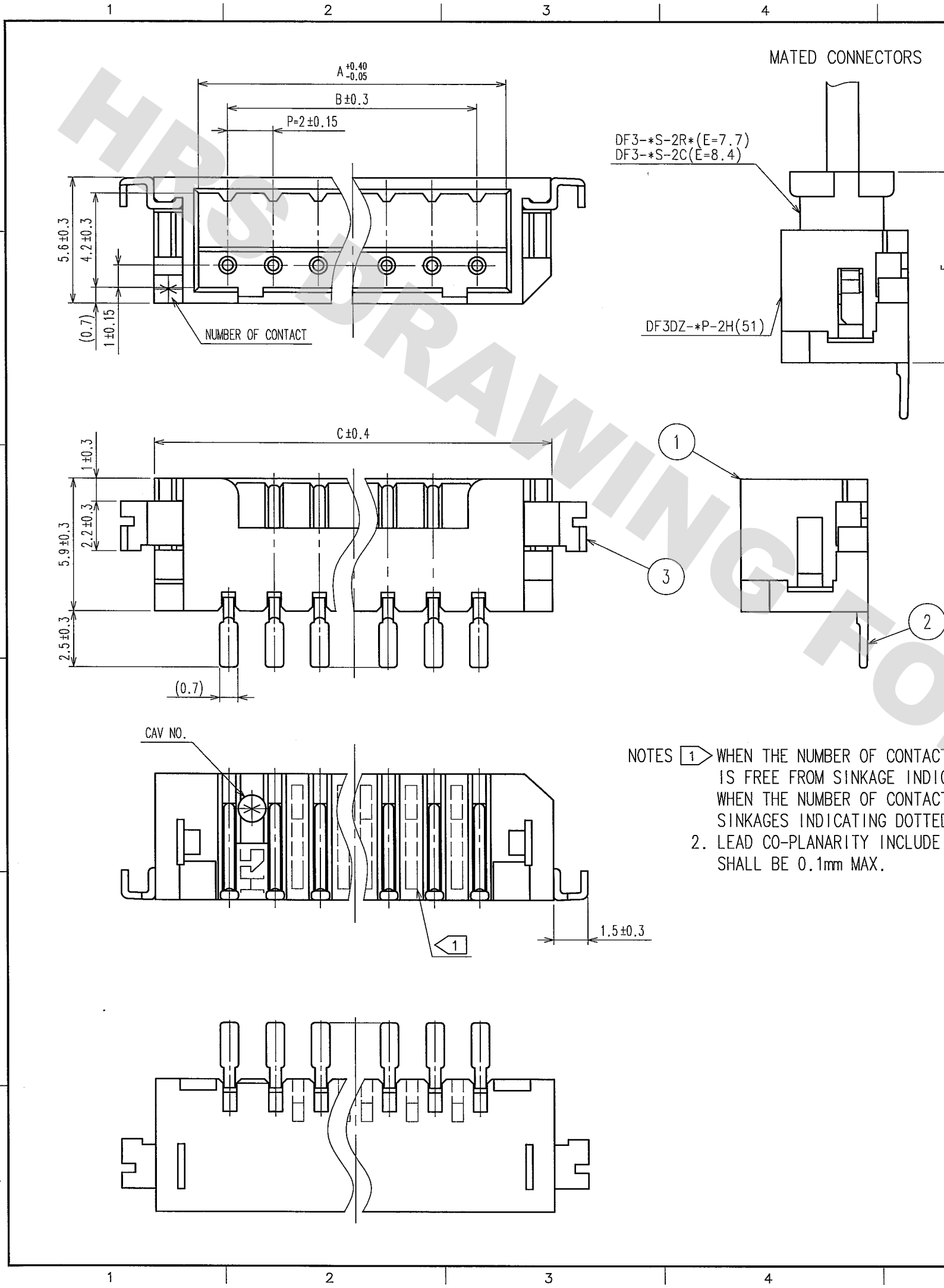

COUNT	DESCRIPTION OF REVISIONS	BY	CHKD	DATE	COUNT	DESCRIPTION OF REVISIONS	BY	CHKD	DATE
2	RE-H-06617	I.D	T.M	'04.11.27					
5	DIS-H-002463	T.O	H.U	07.10.01					

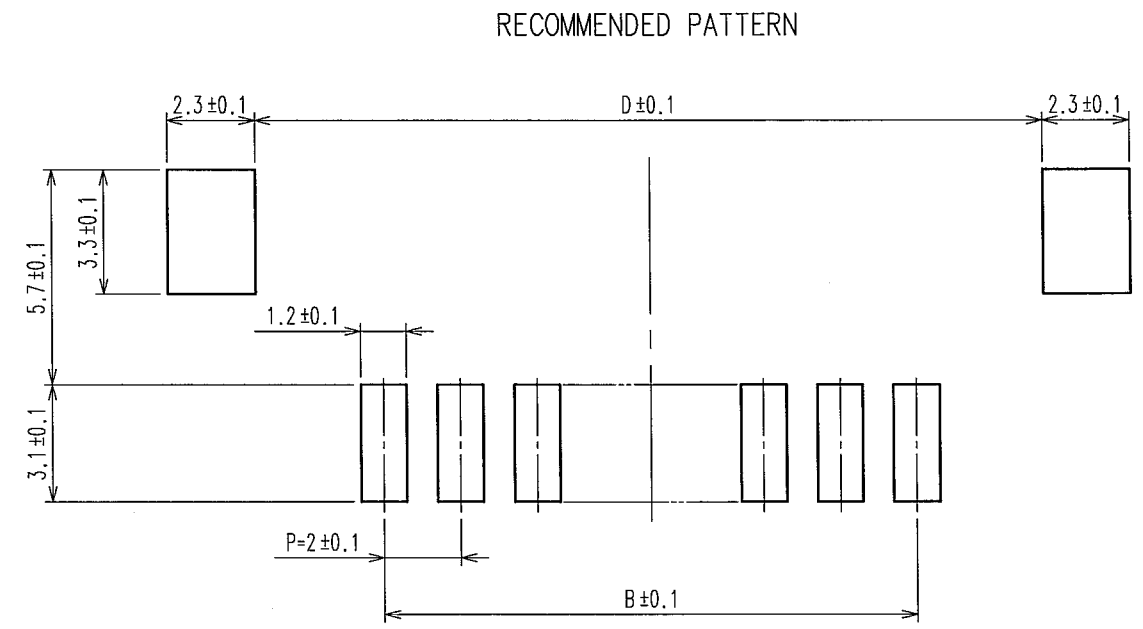

PART NO.	CODE NO.	A	B	C	D
DF3DZ- 2P-2H(51)	CL543-1070-0-51	4.6	2.0	8.5	8.74
DF3DZ- 3P-2H(51)	CL543-1071-3-51	6.6	4.0	10.5	10.74
DF3DZ- 4P-2H(51)	CL543-1072-6-51	8.6	6.0	12.5	12.74
DF3DZ- 5P-2H(51)	CL543-1073-9-51	10.6	8.0	14.5	14.74
DF3DZ- 6P-2H(51)	CL543-1074-1-51	12.6	10.0	16.5	16.74
DF3DZ- 7P-2H(51)	CL543-1075-4-51	14.6	12.0	18.5	18.74
DF3DZ- 8P-2H(51)	CL543-1076-7-51	16.6	14.0	20.5	20.74
DF3DZ- 9P-2H(51)	—	18.6	16.0	22.5	22.74
DF3DZ-10P-2H(51)	CL543-1078-2-51	20.6	18.0	24.5	24.74
DF3DZ-11P-2H(51)	CL543-1079-5-51	22.6	20.0	26.5	26.74
DF3DZ-12P-2H(51)	CL543-1080-4-51	24.6	22.0	28.5	28.74
DF3DZ-13P-2H(51)	—	26.6	24.0	30.5	30.74
DF3DZ-14P-2H(51)	—	28.6	26.0	32.5	32.74
DF3DZ-15P-2H(51)	CL543-1083-2-51	30.6	28.0	34.5	34.74

NOTES 1 WHEN THE NUMBER OF CONTACT IS 2 TO 10, THIS PART IS FREE FROM SINKAGE INDICATING DOTTED LINES. WHEN THE NUMBER OF CONTACT IS 11 TO 15, THERE ARE SINKAGES INDICATING DOTTED LINES.
2. LEAD CO-PLANARITY INCLUDE REINFORCED METAL FITTINGS SHALL BE 0.1mm MAX.

2	BRASS	SURFACE:GOLD PLATED 0.2μ m min UNDER PLATING:NICKEL PLATED 1μ m min	5	POLYESTER	CLEAR(COVER TAPE)	
1	POLYAMIDE	BEIGE,UL94V-0	4	J<6	CLEAR(EMBOSSD CARRIER TAPE)	
			3	BRASS	SURFACE:TIN PLATED 1μ m min UNDER PLATING:NICKEL PLATED 1μ m min	
NO.	MATERIAL	FINISH, REMARKS	NO.	MATERIAL	FINISH, REMARKS	
CODE NO. (OLD) CL		DRAWN M.Nakamoto '04.03.30	DESIGNED H.Umehara '04.03.30	CHECKED T.Miyazaki '04.03.30	APPROVED T.Oma '04.03.31	RELEASED ..
DRAWING NO. EDC3-305941-13			PART NO. DF3DZ-*P-2H(51)			
SCALE 5 : 1			CODE NO. CL543-			
UNITS mm			1/2			

COUNT	DESCRIPTION OF REVISIONS	BY	CHKD	DATE	COUNT	DESCRIPTION OF REVISIONS	BY	CHKD	DATE

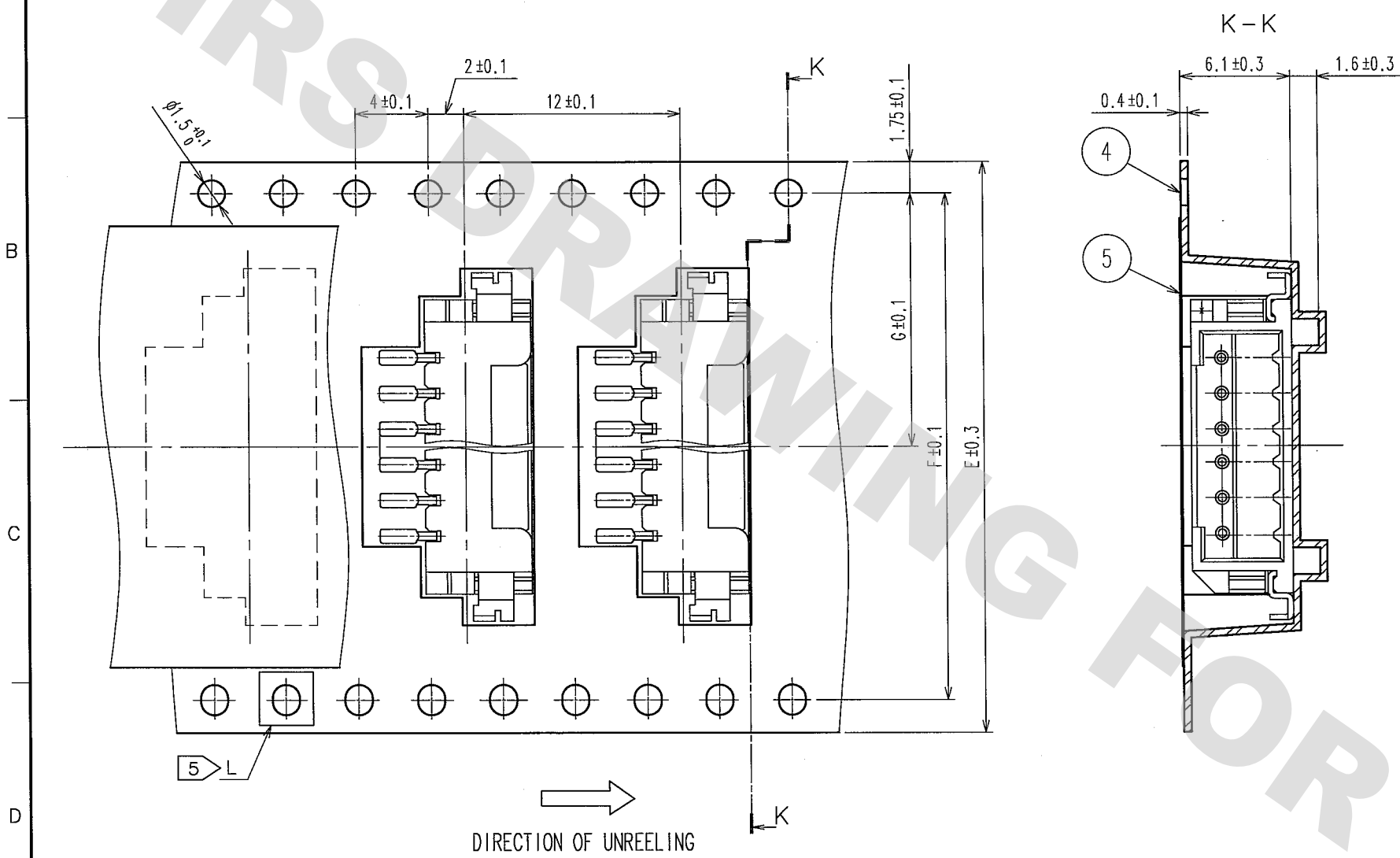

PART NO.	CODE NO.	NUMBER OF CONTACT	E	F	G	H	J
DF3DZ- 2P-2H(51)	CL543-1070-0-51	2	24.0	/	11.5	24.4	PS
DF3DZ- 3P-2H(51)	CL543-1071-3-51	3	24.0	/	11.5	24.4	PS
DF3DZ- 4P-2H(51)	CL543-1072-6-51	4	24.0	/	11.5	24.4	PS
DF3DZ- 5P-2H(51)	CL543-1073-9-51	5	32.0	28.4	14.2	32.4	PS
DF3DZ- 6P-2H(51)	CL543-1074-1-51	6	32.0	28.4	14.2	32.4	PS
DF3DZ- 7P-2H(51)	CL543-1075-4-51	7	32.0	28.4	14.2	32.4	PS
DF3DZ- 8P-2H(51)	CL543-1076-7-51	8	44.0	40.4	20.2	44.4	PS
DF3DZ-10P-2H(51)	CL543-1078-2-51	10	44.0	40.4	20.2	44.4	PS
DF3DZ-11P-2H(51)	CL543-1079-5-51	11	56.0	52.4	26.2	56.4	PS
DF3DZ-12P-2H(51)	CL543-1080-4-51	12	56.0	52.4	26.2	56.4	PS
DF3DZ-15P-2H(51)	CL543-1083-2-51	15	56.0	52.4	26.2	56.4	PS

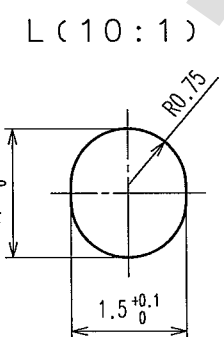

- NOTES
- 1 REEL 1000 CONNECTORS.
 4. AT THE BEGINNING OF THE REEL, 30 COMPONENTS SHALL BE EMPTY. AT THE END OF THE REEL, 20 COMPONENTS SHALL BE EMPTY.
 - 5 WHEN THE TAPE WIDTH IS 32 OR 44 OR 56 mm, SPROCKET HOLES SHALL BE SET ON BOTH SIDES OF REEL AS SHOWN ON THIS DRAWING.
 - 6 THE MATERIAL OF THE EMBOSSED CARRIER TAPE REFERS TO THE TABLE.
 7. THE REEL IS POLYETHYLENE PACKAGED WITH AN DRY AGENT INSIDE FOR MOISTURE-PROOF PACKAGING.
 8. FOR THE STORAGE OF 168 HOURS OR MORE AFTER OPENING THE PACKAGE, KEEP THE PRODUCTS UNDER MOISTURE PROOF CONDITIONS.
 9. EXCEPT ON THE MATING SURFACE, COMPONENT INFLATION DOES NOT AFFECT THE PRODUCTS PERFORMANCE.

STYLE AND DIMENSION OF REEL

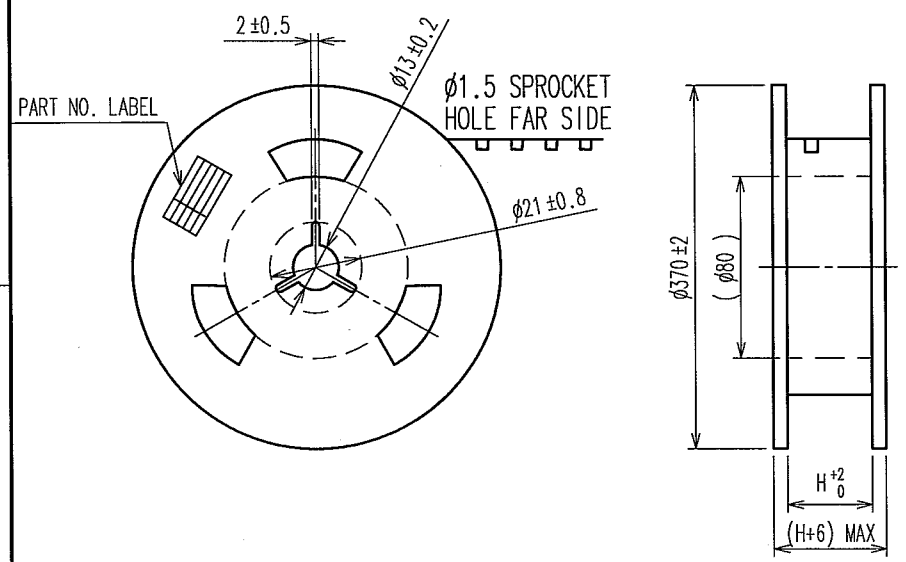

SUPPLIER QUANTITY PART No. CODE No. DATE OF MANUFACTURED

DETAIL OF PART No. LABEL

生産月日	年 月 日
図番	CL543-****-51
品名	DF3DZ-*P-2H(51)
納入数量	1000k o
納入者	ヒロセ電機(株)

NO.	MATERIAL	FINISH, REMARKS	NO.	MATERIAL	FINISH, REMARKS
CODE NO. (OLD)	CL		DRAWN	M.Nakamoto	'04.03.30
			DESIGNED	H.Umehara	'04.03.30
			CHECKED	T.Miyazaki	'04.03.30
			APPROVED	T.Oma	'04.03.31
			RELEASED		

DRAWING NO. EDC3-305941-13

PART NO. DF3DZ-*P-2H(51)

SCALE FR:EE

UNITS mm

CODE NO. CL543-

DRAWING FOR REFERENCE: This is subject to change without notice 08/11/2012

TO