



CY2291/CY2291F/CY2291I
CY2292/CY2292F/CY2292I
CY2295/CY2295I

**Three-PLL General Purpose
 EPROM Programmable Clock Generator**

Features	Benefits
• Three integrated phase-locked loops	Provides all necessary system clocks in a single package
• EPROM programmability	Easy customization and fast turnaround time
• Low skew, low jitter, high accuracy outputs	Meets critical timing requirements in complex system designs
• Power management options (Shutdown, OE, Suspend)	Supports low power applications
• Frequency select option	Enables design flexibility and margin testing
• Smooth slewing on CPUCLK	Allows downstream PLLs to stay locked on CPUCLK output
• 3.3V or 5V operation	Enables application compatibility

Part Number	Outputs	Input Frequency Range	Output Frequency Range	Specifics
CY2291	8	10 MHz–25 MHz (external crystal) 1 MHz–30 MHz (reference clock)	76.923 kHz–100 MHz (5V) 76.923 kHz–80 MHz (3.3V)	Factory Programmable Commercial Temperature
CY2291I	8	10 MHz–25 MHz (external crystal) 1 MHz–30 MHz (reference clock)	76.923 kHz–90 MHz (5V) 76.923 kHz–66.6 MHz (3.3V)	Factory Programmable Industrial Temperature
CY2291F	8	10 MHz–25 MHz (external crystal) 1 MHz–30 MHz (reference clock)	76.923 kHz–90 MHz (5V) 76.923 kHz–66.6 MHz (3.3V)	Field Programmable Commercial Temperature
CY2292	6	10 MHz–25 MHz (external crystal) 1 MHz–30 MHz (reference clock)	76.923 kHz–100 MHz (5V) 76.923 kHz–80 MHz (3.3V)	Factory Programmable Commercial Temperature
CY2292I	6	10 MHz–25 MHz (external crystal) 1 MHz–30 MHz (reference clock)	76.923 kHz–90 MHz (5V) 76.923 kHz–66.6 MHz (3.3V)	Factory Programmable Industrial Temperature
CY2292F	6	10 MHz–25 MHz (external crystal) 1 MHz–30 MHz (reference clock)	76.923 kHz–90 MHz (5V) 76.923 kHz–66.6 MHz (3.3V)	Field Programmable Commercial Temperature
CY2295	8	10 MHz–25 MHz (external crystal) 1 MHz–30 MHz (reference clock)	76.923 kHz–100 MHz (5V) 76.923 kHz–80 MHz (3.3V)	Factory Programmable Commercial Temperature
CY2295I	8	10 MHz–25 MHz (external crystal) 1 MHz–30 MHz (reference clock)	76.923 kHz–90 MHz (5V) 76.923 kHz–66.6 MHz (3.3V)	Factory Programmable Industrial Temperature

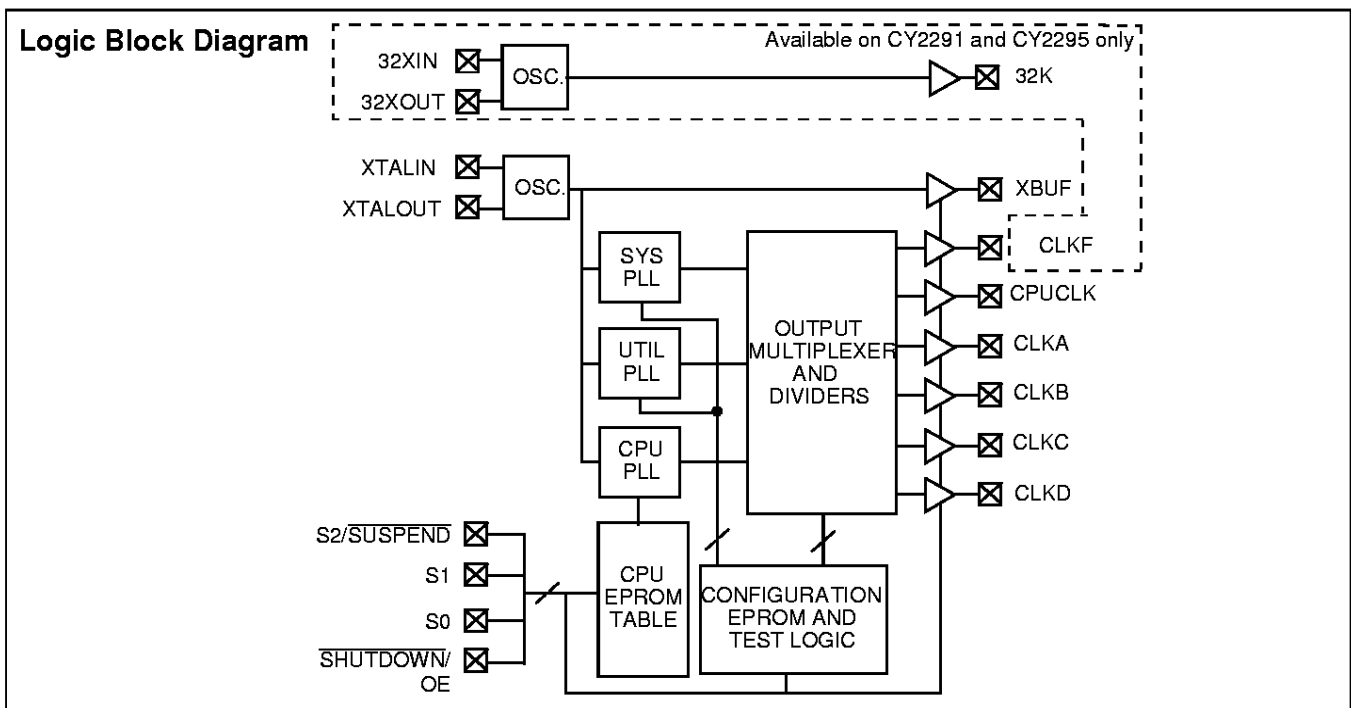



Pin Configurations

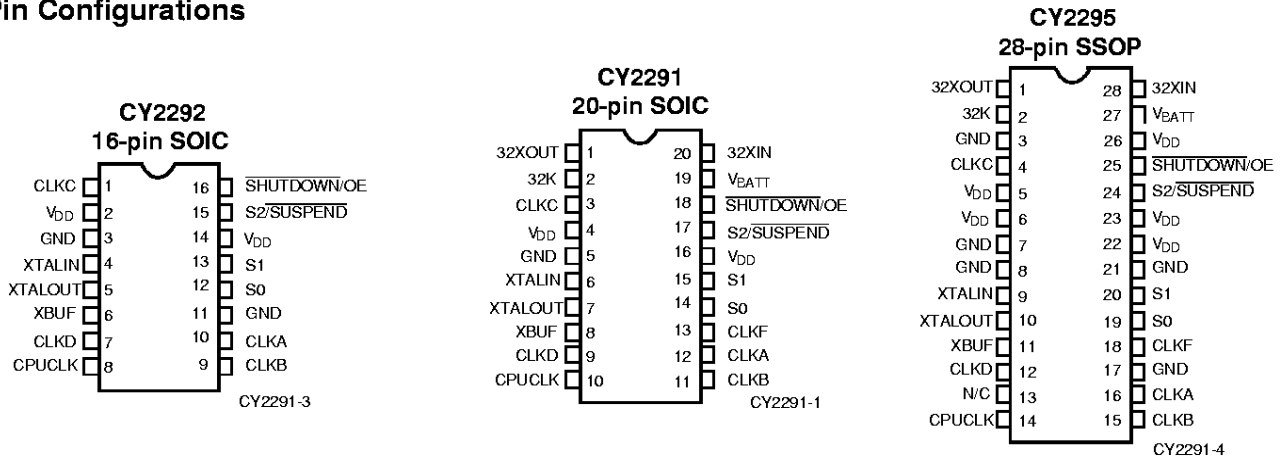

Pin Summary

Name	Pin Number CY2291	Pin Number CY2292	Pin Number CY2295	Description
32XOUT	1	—	1	32.768 kHz crystal feedback
32K	2	—	2	32.768 kHz output (always active if V _{BATT} is present)
CLKC	3	1	4	Configurable clock output C
V _{DD}	4, 16	2, 14	5, 6, 22, 23, 26	Voltage supply
GND	5	3, 11	3, 7, 8, 17, 21	Ground
XTALIN ^[1]	6	4	9	Reference crystal input or external reference clock input
XTALOUT ^[1, 2]	7	5	10	Reference crystal feedback
XBUF	8	6	11	Buffered reference clock output
CLKD	9	7	12	Configurable clock output D
CPUCLK	10	8	14	CPU frequency clock output
CLKB	11	9	15	Configurable clock output B
CLKA	12	10	16	Configurable clock output A
CLKF	13	—	18	Configurable clock output F
S0	14	12	19	CPU clock select input, bit 0
S1	15	13	20	CPU clock select input, bit 1
S2/SUSPEND	17	15	24	CPU clock select input, bit 2. Optionally enables suspend feature when LOW ^[3]
SHUTDOWN/OE	18	16	25	Places outputs in three-state ^[4] condition and shuts down chip when LOW. Optionally, only places outputs in three-state ^[4] condition and does not shut down chip when LOW
V _{BATT}	19	—	27	Battery supply for 32.768-kHz circuit
32XIN	20	—	28	32.768-kHz crystal input

Notes:

- For best accuracy, use a parallel-resonant crystal, C_{LOAD} ≈ 17 pF or 18 pF.
- Float XTALOUT pin if XTALIN is driven by reference clock (as opposed to crystal).
- Please refer to application note "Understanding the CY2291, CY2292 and CY2295" for more information.
- The CY2291 has weak pull-downs on all outputs (except 32K). Hence, when a three-state condition is forced on the outputs, the output pins are pulled LOW.



Operation

The CY2291, CY2292 and CY2295 are a third-generation family of clock generators. The CY2291 is upwardly compatible with the industry standard ICD2023 and ICD2028 and continues their tradition by providing a high level of customizable features to meet the diverse clock generation needs of modern motherboards and other synchronous systems. The CY2292 differs from the CY2291 in that it comes in a 16-pin 150-mil SOIC package, and does not provide either the 32-kHz or CLKF outputs. The CY2295 is available in a space-saving 28-pin SSOP package.

All parts provide a highly configurable set of clocks for PC motherboard applications. Each of the four configurable clock outputs (CLKA–CLKD) can be assigned 1 of 30 frequencies in any combination. Multiple outputs configured for the same or related^[3] frequencies will have low (≤ 500 ps) skew, in effect providing on-chip buffering for heavily loaded signals.

The CY2291, CY2292, and CY2295 can be configured for either 5V or 3.3V operation. The internal ROM tables use EPROM technology, allowing full customization of output frequencies. The reference oscillator has been designed for 10-MHz to 25-MHz crystals, providing additional flexibility. No external components are required with this crystal. Alternatively, an external reference clock of frequency between 1 MHz and 30 MHz can be used. Customers using the 32-kHz oscillator on the CY2291 or CY2295 should connect a 10-M Ω resistor in parallel with the 32-kHz crystal.

Output Configuration

The CY2291 and CY2295 (and CY2292) have five (four) independent frequency sources on chip. These are the 32-kHz oscillator (not available on CY2292), the reference oscillator, and three Phase Locked Loops (PLLs). Each PLL has a specific function. The System PLL (SPLL) drives the CLKF output (not available on CY2292) and provides fixed output frequencies on the configurable outputs. The SPLL offers the most output frequency divider options. The CPU PLL (CPLL) is controlled by the select inputs (S0–S2) to provide eight user-selectable frequencies with smooth slewing between frequencies. The Utility PLL (UPLL) provides the most accurate clock. It is often used for miscellaneous frequencies not provided by the other frequency sources.

All configurations are EPROM programmable, providing short sample and production lead times. Please refer to the application note “Understanding the CY2291, CY2292, and CY2295” for information on configuring the part.

Power Saving Features

The $\overline{\text{SHUTDOWN/OE}}$ input three-states the outputs when pulled LOW (the 32-kHz clock output is not affected). If system shutdown is enabled (the default), a LOW on this pin also shuts off the PLLs, counters, the reference oscillator, and all other active components. The resulting current on the V_{DD} pins will be less than 50 μA (for Commercial Temp. or 100 μA for Industrial Temp.) plus 15 μA max. for the 32-kHz subsystem and is typically 10 μA . After leaving shutdown mode, the PLLs will have to re-lock. All outputs except 32K have a weak pull-down so that the outputs do not float when three-stated.^[4]

The $\overline{\text{S2/SUSPEND}}$ input can be configured to shut down a customizable set of outputs and/or PLLs, when LOW. All PLLs and any of the outputs except 32K can be shut off in nearly any combination. The only limitation is that if a PLL is shut off, all outputs derived from it must also be shut off. Suspending a PLL shuts off all associated logic, while suspending an output simply forces a three-state condition.^[3]

The CPUCLK can slew (transition) smoothly between 8 MHz and the maximum output frequency (100 MHz at 5V/80 MHz at 3.3V for Commercial Temp. parts or 90 MHz at 5V/66.6 MHz at 3.3V for Industrial Temp. and for field-programmed parts). This feature is extremely useful in “Green” PC and laptop applications, where reducing the frequency of operation can result in considerable power savings. This feature meets all 486 and Pentium processor slewing requirements.

CyClocks™ Software

CyClocks is an easy-to-use application that allows you to configure any one of the EPROM programmable clocks offered by Cypress. You may specify the input frequency, PLL & output frequencies, and different functional options. Please note the output frequency ranges in this datasheet when specifying them in CyClocks to ensure that you stay within the limits. CyClocks also has a power calculation feature that allows you to see the power consumption of your specific configuration. You can download a copy of CyClocks for free on Cypress’s website at www.cypress.com.



Maximum Ratings

(Above which the useful life may be impaired. For user guidelines, not tested.)

Supply Voltage	-0.5V to +7.0V
DC Input Voltage	-0.5V to +7.0V
Storage Temperature	-65°C to +150°C

Max. Soldering Temperature (10 sec)	260°C
Junction Temperature	150°C
Package Power Dissipation	750 mW
Static Discharge Voltage	>2000V (per MIL-STD-883, Method 3015)

Operating Conditions^[5]

Parameter	Description	Part Numbers	Min.	Max.	Unit
V _{DD}	Supply Voltage, 5.0V (3.3V) operation	All	4.5 (3.0)	5.5 (3.6)	V
V _{BATT}	Battery Backup Voltage	All	2.0	5.5	V
T _A	Operating Temperature, Ambient	CY2291/CY2291F CY2292/CY2292F CY2295	0	+70	°C
		CY2291I CY2292I CY2295I	-40	+85	°C
C _{LOAD}	Max. Load Capacitance 5.0V (3.3V) Operation	All		25 (15)	pF
f _{REF}	Reference Frequency	All	10.0	25.0	MHz
f _{REF}	Reference Frequency, External Reference Clock ^[6, 7]	All	1	30	MHz

Electrical Characteristics

Parameter	Description	Conditions	Min.	Typ.	Max.	Unit
V _{OH} ^[8]	HIGH-Level Output Voltage	I _{OH} = 4.0 mA	2.4			V
V _{OL} ^[8]	LOW-Level Output Voltage	I _{OL} = 4.0 mA			0.4	V
V _{OH-32}	32.768-kHz HIGH-Level Output Voltage	I _{OH} = 0.5 mA	V _{BATT} 0.5			V
V _{OL-32}	32.768-kHz LOW-Level Output Voltage	I _{OL} = 0.5 mA			0.4	V
V _{IH}	HIGH-Level Input Voltage ^[9]	Except crystal pins	2.0			V
V _{IL}	LOW-Level Input Voltage ^[9]	Except crystal pins			0.8	V
I _{IH}	Input HIGH Current	V _{IN} = V _{DD} -0.5V		< 1	10	μA
I _{IL}	Input LOW Current	V _{IN} = +0.5V		< 1	10	μA
I _{OZ}	Output Leakage Current	Three-state outputs			250	μA
I _{DD}	V _{DD} Supply Current ^[10]	V _{DD} = V _{DD} max., 5V (3.3V) operation		75(50)	100(65)	mA
I _{DDS}	V _{DD} Power Supply Current in Shutdown Mode ^[10]	Shutdown active, excluding V _{BATT}	CY2291/CY2291F CY2292/CY2292F CY2295	10	50	μA
			CY2291I CY2292I CY2295I	10	100	μA
I _{BATT}	V _{BATT} Power Supply Current	V _{BATT} = 3.0V		5	15	μA

Notes:

- Electrical parameters are guaranteed with these operating conditions.
- External input reference clock must have a duty cycle between 40% and 60%, measured at V_{DD}/2.
- Please refer to application note "Crystal Oscillator Topics" for information on AC-coupling the external input reference clock.
- All outputs swing rail to rail.
- Xtal inputs have CMOS thresholds.
- Load = Max., V_{IN} = 0V or V_{DD}, Typical (-104) configuration, CPUCLK = 66 MHz. Other configurations will vary. Power can be approximated by the following formula (multiply by 0.65 for 3V operation):

$$I_{DD} = 10 + 0.06 \cdot (F_{CPLL} + F_{UPLL} + 2 \cdot F_{SPLL}) + 0.27 \cdot (F_{CLKA} + F_{CLKB} + F_{CLKC} + F_{CLKD} + F_{CPUCLK} + F_{CLKF} + F_{XBUF})$$



Switching Characteristics^[11]

Parameter	Name	Description	Min.	Typ.	Max.	Unit	
t ₁	Output Period	Clock output range, 5V operation	CY2291 CY2292 CY2295	10 (100 MHz)		13000 (76.923 kHz)	ns
			CY2291F/CY2291I CY2292F/CY2291I CY2295I	11.1 (90 MHz)		13000 (76.923 kHz)	ns
t ₁	Output Period	Clock output range, 3.3V operation	CY2291 CY2292 CY2295	12.5 (80 MHz)		13000 (76.923 kHz)	ns
			CY2291F/CY2291I CY2292F/CY2291I CY2295I	15 (66.6 MHz)		13000 (76.923 kHz)	ns
	Output Duty Cycle ^[12]	Duty cycle for outputs, defined as $t_2 \div t_1$ ^[13] f _{OUT} ≥ 66 MHz		40%	50%	60%	
		Duty cycle for outputs, defined as $t_2 \div t_1$ ^[13] f _{OUT} < 66 MHz		45%	50%	55%	
t ₃	Rise Time	Output clock rise time ^[14]		3	5	ns	
t ₄	Fall Time	Output clock fall time ^[14]		2.5	4	ns	
t ₅	Output Disable Time	Time for output to enter three-state mode after SHUTDOWN/OE goes LOW		10	15	ns	
t ₆	Output Enable Time	Time for output to leave three-state mode after SHUTDOWN/OE goes HIGH		10	15	ns	
t ₇	Skew	Skew delay between any identical or related outputs ^[3, 13]		<0.25	0.5	ns	
t ₈	CPUCLK Slew	Frequency transition rate	1.0		20.0	MHz/ ms	
t _{9A}	Clock Jitter ^[15]	Peak-to-peak period jitter (t _{9A} max. – t _{9A} min.), % of clock period (f _{OUT} ≤ 4 MHz)		<0.5	1	%	
t _{9B}	Clock Jitter ^[15]	Peak-to-peak period jitter (t _{9B} max. – t _{9B} min.) (4 MHz ≤ f _{OUT} ≤ 16 MHz)		<0.7	1	ns	
t _{9C}	Clock Jitter ^[15]	Peak-to-peak period jitter (16 MHz < f _{OUT} ≤ 50 MHz)		<400	500	ps	
t _{9D}	Clock Jitter ^[15]	Peak-to-peak period jitter (f _{OUT} > 50 MHz)		<250	350	ps	
t _{10A}	Lock Time for CPLL	Lock Time from Power-up		<25	50	ms	
t _{10B}	Lock Time for UPLL and SPLL	Lock Time from Power-up		<0.25	1	ms	
	Slew Limits	CPU PLL Slew Limits	CY2291 CY2292 CY2295	8		100 (5V) 80 (3.3V)	MHz
			CY2291F/CY2291I CY2292F/CY2291I CY2295I	8		90 (5V) 66.6 (3.3V)	MHz

Notes:

11. Guaranteed by design and characterization, not 100% tested in production.
12. XBUF duty cycle depends on XTALIN duty cycle.
13. Measured at 1.4V.
14. Measured between 0.4V and 2.4V.
15. Jitter varies with configuration. All standard configurations sample tested at the factory conform to this limit. For more information on jitter, please refer to the application note: "Jitter in PLL-Based Systems."

Switching Waveforms

All Outputs, Duty Cycle and Rise/Fall Time

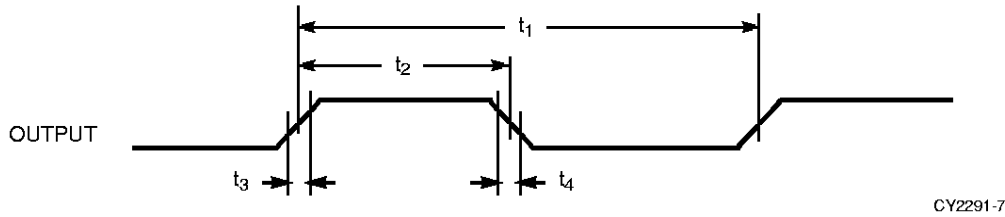

Output Three-State Timing^[4]

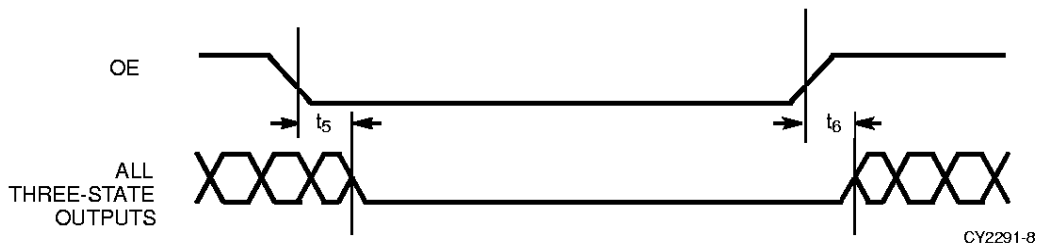

CLK Outputs Jitter and Skew

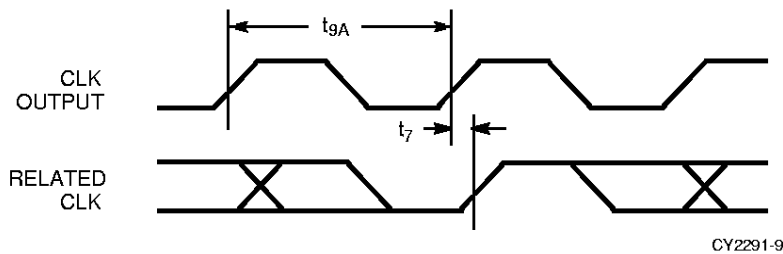

CPU Frequency Change

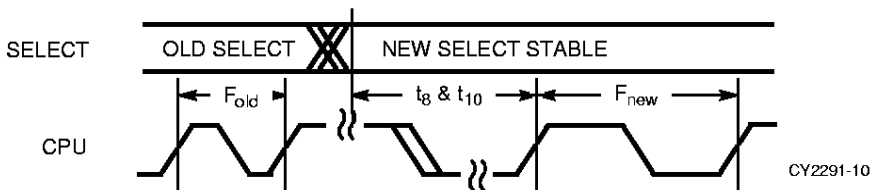



Test Circuit

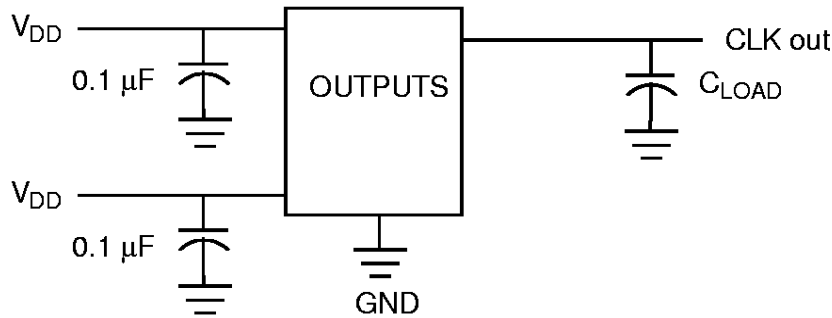

CY2291-11

Ordering Information

Ordering Code	Package Name	Package Type	Operating Range	Operating Voltage
CY2291SC-XXX	S5	20-Pin SOIC	Commercial	5.0V
CY2292SC-XXX	S16	16-Pin SOIC	Commercial	5.0V
CY2295PVC-XXX	O28	28-Pin SSOP	Commercial	5.0V
CY2291SL-XXX	S5	20-Pin SOIC	Commercial	3.3V
CY2292SL-XXX	S16	16-Pin SOIC	Commercial	3.3V
CY2295PVL-XXX	O28	28-Pin SSOP	Commercial	3.3V
CY2291F	S5	20-Pin SOIC	Commercial	3.3V or 5.0V
CY2292F	S16	16-Pin SOIC	Commercial	3.3V or 5.0V
CY2291SI-XXX	S5	20-Pin SOIC	Industrial	3.3V or 5.0V
CY2292SI-XXX	S16	16-Pin SOIC	Industrial	3.3V or 5.0V
CY2295PVI-XXX	O28	28-Pin SSOP	Industrial	3.3V or 5.0V

Document #: 38-00410-D

Custom Configuration Request Procedure

The CY229x are EPROM-programmable devices which may be configured in the factory or in the field by a Cypress Field Application Engineer (FAE). The output frequencies requested will be matched as closely as the internal PLL divider and multiplier options allow. All custom requests must be submitted to your local Cypress FAE or sales representative. There are two methods to use to request custom configurations:

1. Use CyClocks™ software. This software automatically calculates the output frequencies that can be generated by the CY229x devices and provides a print-out of final pinout which can be submitted (in electronic or print format) to your local FAE or sales representative. The CyClocks software is available free-of-charge from the Cypress website (<http://www.cypress.com>) or from your local sales representative.
2. Use the custom configuration form attached. All areas must be filled in with the exception of shaded cells and the form submitted to the appropriate Cypress FAE or sales representative.

If requesting samples through the factory:

Once the custom request has been processed you will receive a part number with a 3-digit extension (e.g., CY2292SC-128) specific to the frequencies and pinout of your device. This will be the part number used for samples requests and production orders.



CY2291/2/5 CUSTOM CONFIGURATION REQUEST FORM
 (Please submit to your local FAE or sales representative)

Company _____ Engineer _____ FAE/Sales _____
 Phone# _____ Fax# _____ Date _____

CIRCLE ONE **CY2291** **CY2292** **CY2295**

The CY2291, CY2295, and CY2292 are the industry's most flexible frequency synthesizers, offering a high degree of configurability due to their unique internal programmable EPROM array. Of the CY2291/2/5's outputs, six (five on the CY2292) may be defined within the scope of the PLL frequencies and divider criteria described in the following. Shaded areas are for Cypress use only. Contact your local Cypress representative for assistance.

1. **OPERATING VOLTAGE** (Circle one) **3.3V** **5.0V**
2. **INPUT REFERENCE FREQUENCY** (Circle one) **Crystal** **External Clock** **14.31818 MHz** (Default)
 If a different reference is required, specify the frequency in the box to the right
 (must be between 10 MHz and 25 MHz for crystal, 1 MHz and 30 MHz for external clock):

3. **CPU-PLL (CPLL) FREQUENCIES** ("Off" is a valid selection for any address and will automatically be entered for blanks.)
- | Select | Requested | Actual |
|----------|-----------|--------|
| S2 S1 S0 | | |
| 0 0 0 | | |
| 0 0 1 | | |
| 0 1 0 | | |
| 0 1 1 | | |
| 1 0 0 | | |
| 1 0 1 | | |
| 1 1 0 | | |
| 1 1 1 | | |
- If the Suspend Option is specified in #7 below, the Select MSB (S2) serves a dual function as both the MSB CPU address and as the Suspend select pin. The CPU frequencies specified for addresses 000–011 will be active unless the CPU-PLL is shut down during the suspend mode (CPU-PLL is circled in #7). Also, any outputs derived from a non-suspended CPU-PLL (assigned in #5 as options 5–8) that are not circled in #7 will remain active during the suspend mode.
- Range: 8–100 MHz at 5V; 8–80 MHz at 3.3V (Commercial)
 8–90 MHz at 5V, 8–66.6 MHz at 3.3V (Industrial/Field-Prog)
 Default = "Off" for all selections

4. **UTILITY-PLL (UPLL) AND SYSTEM-PLL (SPLL) FREQUENCIES** ("Off" is a valid frequency selection for either PLL.)
 To minimize harmonic effects, avoid setting any PLL to an equal or multiple frequency of another PLL.
- | Requested | Actual | Requested | Actual |
|--|---|--|---|
| UPLL | | SPLL | |
- Range: 8–100 MHz at 5V; 8–80 MHz at 3.3V (Commercial)
 8–90 MHz at 5V, 8–66.6 MHz at 3.3V (Industrial/Field-Prog)
 Default = 96 MHz at 5V; 48 MHz at 3.3V

5. **OUTPUT CONFIGURATION** ("Off" is a valid selection for any output and will automatically be entered for blanks.)
 Assign by number from the Output Options Table below and fill in the Frequency column as a double-check.

Output Options Table

1. Ref	6. CPll/2	11. UPLL/4	16. SPll/4	21. SPll/12	26. SPll/40
2. Ref/2	7. CPll/4	12. UPLL/8	17. SPll/5	22. SPll/13	27. SPll/48
3. Ref/4	8. CPll/8	13. SPll	18. SPll/6	23. SPll/20	28. SPll/52
4. Ref/8	9. UPLL	14. SPll/2	19. SPll/8	24. SPll/24	29. SPll/96
5. CPll	10. UPLL/2	15. SPll/3	20. SPll/10	25. SPll/26	30. SPll/104

	Option	Frequency
32K (Fixed 32 kHz)	–	32.768kHz
CLKF (Options 14–16, Off)		
XBUF (Option 1 only)	1	
GPUCLK (Options 5–7, Off)		

32K and CLKF are not available on the CY2292.

	Option	Frequency
CLKA (Options 1–30, Off)		
CLKB (Options 1–30, Off)		
CLKC (Options 1–30, Off)		
CLKD (Options 1–30, Off)		

For CLKD only: option #4 (Ref/8) is replaced with Ref/3.

6. **SHUTDOWN OPTION** (Circle Yes or No) **Yes** **No**
7. **SUSPEND OPTION** (Circle Yes or No) **Yes** **No**
- IF SUSPEND = "Yes": Circle each resource to be shut down when the Suspend mode is active (S2=0). Note that suspending a PLL automatically suspends its outputs.
- | | | |
|----------|--------|------|
| CPU-PLL | XBUF | CLKA |
| UTIL-PLL | GPUCLK | CLKB |
| SYS-PLL | CLKF | CLKC |
| | | CLKD |

FOR CYPRESS USE ONLY (Shaded Areas above and below)

Customer Configuration	Marking
Date	Quantity

Package Diagrams

20-Lead (300-Mil) Molded SOIC S5

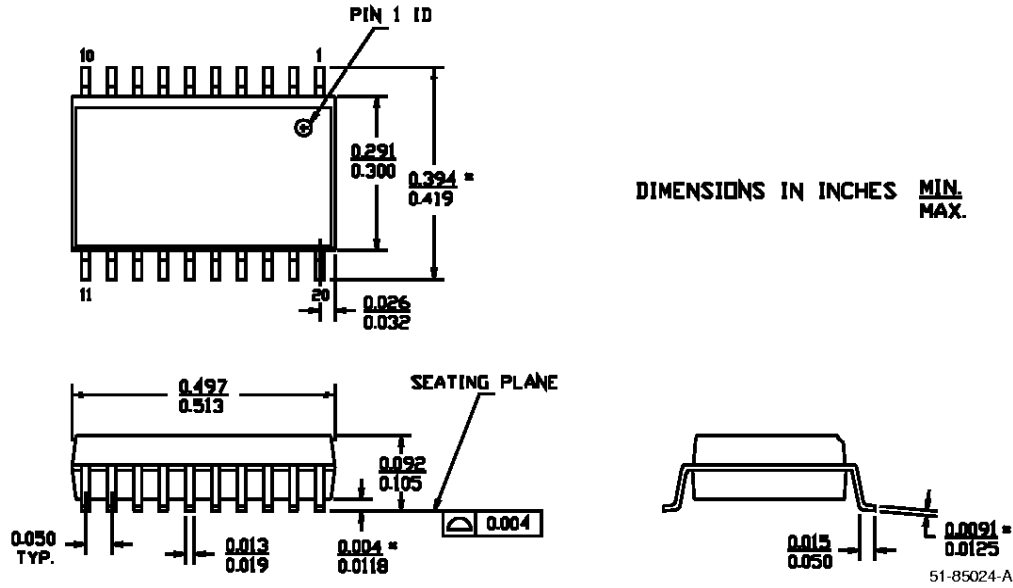

16-Lead (150-Mil) Molded SOIC S16

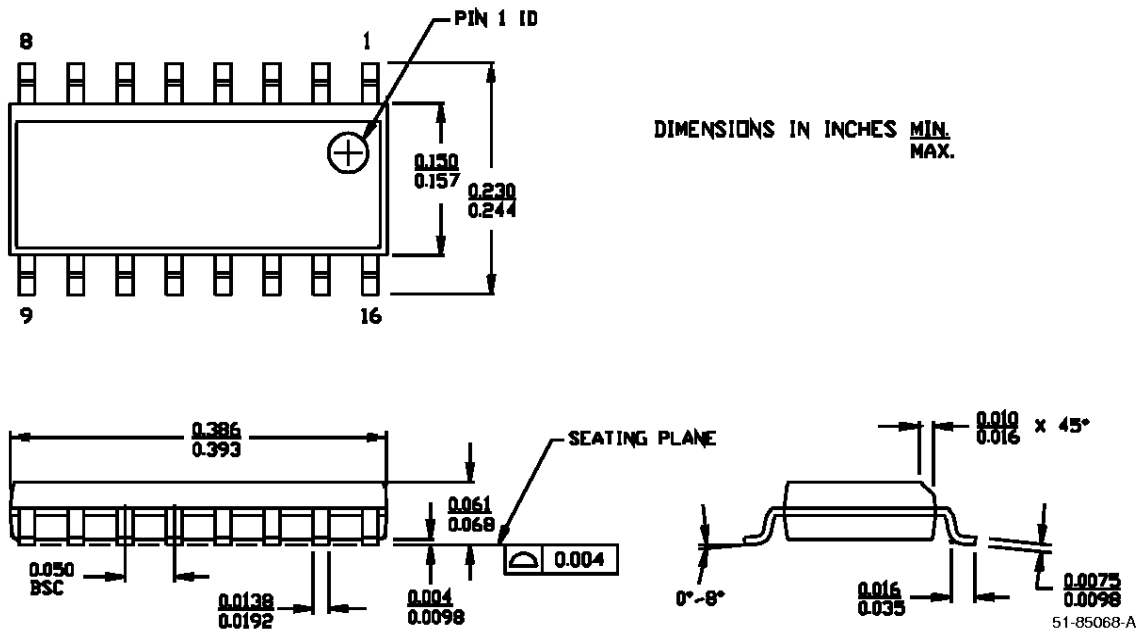



Package Diagrams (continued)

28-Lead (210-Mil) Shrunk Small Outline Package O28

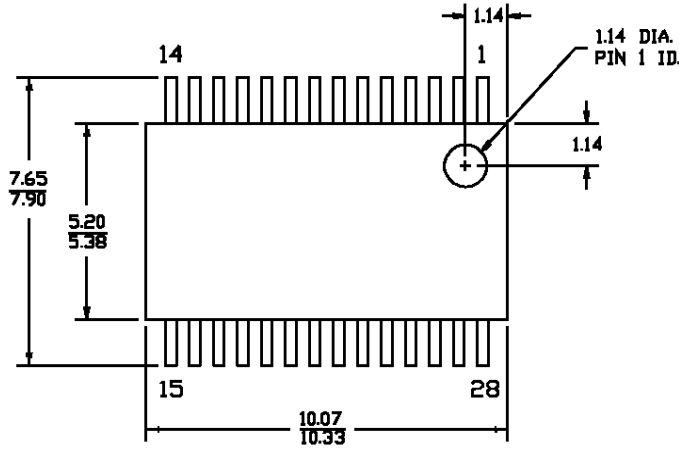

DIMENSIONS IN MILLIMETERS MIN.
MAX.

