

Customer Information Sheet

DRAWING No.: M80-804XXXX

SHEET 2 OF 2

IF IN DOUBT - ASK

©

NOT TO SCALE

THIRD ANGLE PROJECTION

ALL DIMENSIONS IN mm

SPECIFICATIONS:

MATERIAL:
 MOULDING = GLASS-FILLED PBT,
 UL94V-0, BLACK
 CONTACTS = PHOSPHOR BRONZE
 LATCHES = BERYLLIUM COPPER
FINISH:
 CONTACTS:
 05 = 0.75µ GOLD
 22 = 0.75µ GOLD ON CONTACT AREA.
 3.0µ 90/10 TIN/LEAD ON TAILS
 LATCH = 1.25µ NICKEL
ELECTRICAL:
 CURRENT RATING (25°C) = 3.0A MAX.
 CURRENT RATING (85°C) = 2.2A MAX.
 WORKING VOLTAGE = 120V AC/DC
 VOLTAGE PROOF = 360V AC/DC
 CONTACT RESISTANCE:
 INITIAL = 20 mΩ MAX.
 AFTER CONDITIONING = 25 mΩ MAX.
 INSULATION RESISTANCE:
 INITIAL = 1000 MΩ MIN.
 AFTER CONDITIONING = 100 MΩ MIN.
MECHANICAL:
 DURABILITY = 500 OPERATIONS
ENVIRONMENTAL:
 TEMPERATURE RANGE = -55°C TO +125°C
PACKING:
 TUBE
 FOR COMPLETE SPECIFICATION, SEE COMPONENT SPECIFICATION C005XX (LATEST ISSUE)

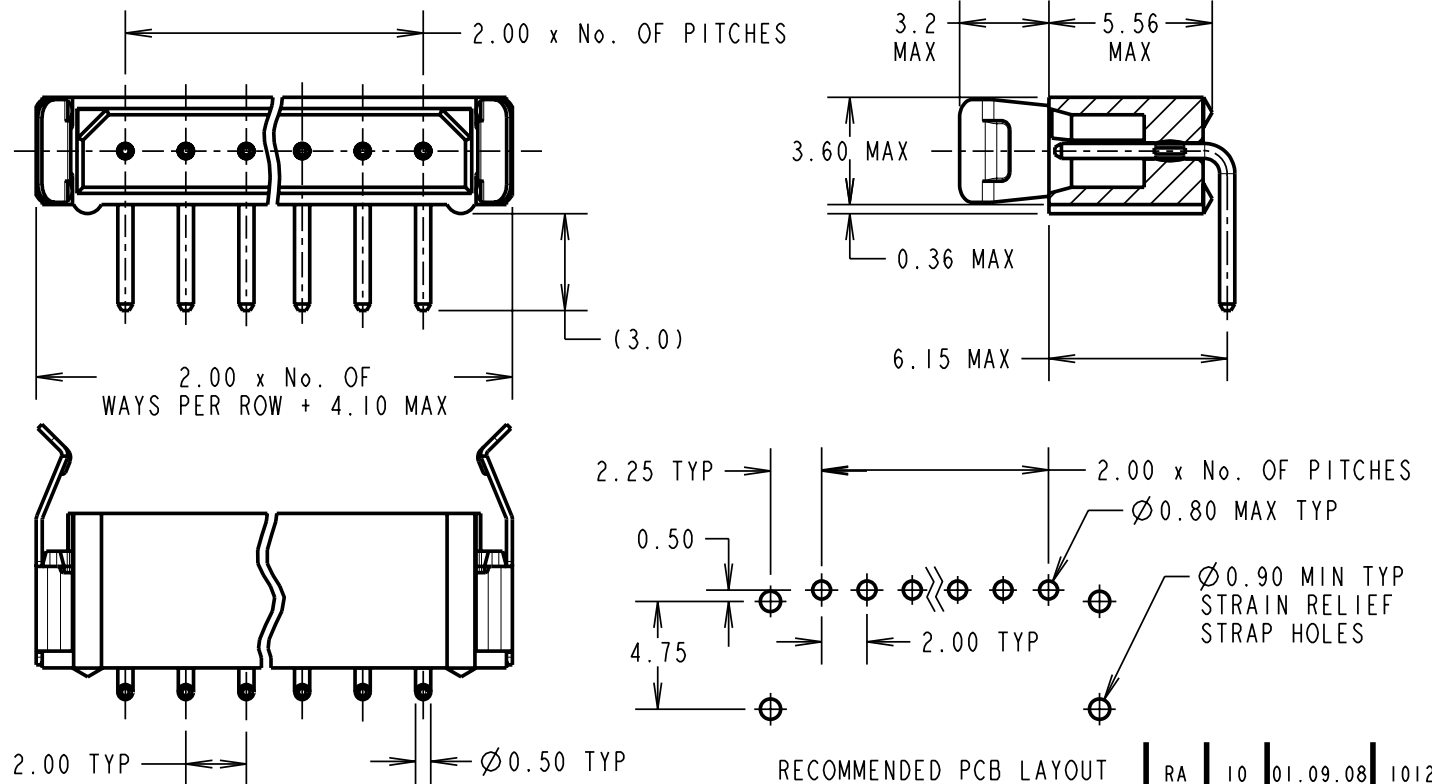

RECOMMENDED PCB LAYOUT

OBSELETE
 All B5743 versions
 LTB date 09-03-2018
 C/N 20971

NOTES:

- 2-OFF STRAIN RELIEF STRAPS M80-0030006 ARE INCLUDED WITH THIS CONNECTOR.
- FOR RoHS COMPLIANT EQUIVALENT PRODUCT USE M80-846XXXX CONNECTORS.

~~BRITISH STANDARD ORDER CODE:
B5743-1XX-M-L-Y
 TOTAL No. OF WAYS
 02 - 07, 17, 22
 FINISH:
 Y = SELECTIVE GOLD & TIN/LEAD~~

ORDER CODE:
M80-804XXXX
 TOTAL No. OF WAYS
 02 - 07, 17, 22.
 FINISH:
 05 = GOLD
 22 = SELECTIVE GOLD & TIN/LEAD

RA	10	01.09.08	10127
NAME	ISS.	DATE	C/NOTE
APPROVED:		R. ADDE	
CHECKED:		M.G.PLESTED	
DRAWN:		D. BECK	
CUSTOMER REF.:			
ASSEMBLY DRG:			

HARWIN

HARWIN USA
 TEL: 603 893 5376
 FAX: 603 893 5396
 mis@harwin.com

HARWIN Europe (UK)
 TEL: 023 9231 4545
 FAX: 023 9231 4590
 mis@harwin.co.uk

HARWIN Asia
 TEL: +65 6 779 4909
 FAX: +65 6 779 3868
 mis@harwin.com.sg

THIS DRAWING AND ANY INFORMATION OR DESCRIPTIVE MATTER SET OUT HEREON ARE CONFIDENTIAL AND COPYRIGHT PROPERTY OF THE HARWIN GROUP AND MUST NOT BE DISCLOSED, LOANED, COPIED OR USED FOR MANUFACTURING, TENDERING OR FOR ANY OTHER PURPOSE WITHOUT THEIR WRITTEN PERMISSION.

TOLERANCES
 X. = ±1mm
 X.X = ±0.25mm
 X.XX = ±0.10mm
 X.XXX = ±0.01mm
ANGLES = ±5°
 UNLESS STATED

MATERIAL:
 SEE ABOVE
FINISH:
 SEE ABOVE
S/AREA:
 mm²

TITLE:
 DATAMATE SIL
 HORIZONTAL MALE PC TAIL
 ASSEMBLY - FRICTION LATCH
DRAWING NUMBER:
M80-804XXXX
 SHT
 2 OF 2