

GS820V32Q/T

4/5/6, 2.5V I/O, 2.0mA

64K x 32 Burst

80-133MHz (P/L)

66MHz (FT)

Features

- Single 3.3V +5%/ -5% power supply
- Separate VDDQ to allow 2.375V to 3.465V output supply level
- High frequency operation: 133MHz
- Fast access time: 4.5ns Clock to Q
- Low power: 0.5mA ISB and IDD static
- FT mode pin for either flow-thru or pipeline operation
- LBO mode pin for linear or interleave (Pentium™ and X86) burst mode
- Byte write (BWE) and global write (GW) operation
- 3 chip enable signals for easy depth expansion
- 2 cycles enable (pipeline mode) and 1 cycle disable to allow multiple bank without data buss contention
- Compatible to both 3.3V and 2.5V interface level
- Standard Industrial Temperature Option: -40 to +85C
- JEDEC standard 100 lead package:

Q: QFP
T: TQFP

Pentium is a trademark of Intel Corp.

Functional Description

The GS820V32 is a 64Kx32 high performance synchronous SRAM with 2 bit burst counter. It is designed to provide L2 Cache for Pentium™ and other high performance CPU. Addresses (A0-15), data IOs (DQ1-32), chip enables (CE1, CE2, CE3), address control inputs (ADSP, ADSC, ADV) and write control inputs (BWT, BW2, BW3, BW4, BWE, GW) are synchronous and are controlled by a positive edge triggered clock (CLK).

Output enable (OE) and power down control (ZZ) are asynchronous. 2 mode control pins (LBO & FT) define 4 operation modes of linear/interleave burst order and output flow-thru/pipeline. Burst can be initiated with either ADSP or ADSC inputs. Subsequent burst address are generated internally and are controlled by ADV. The burst sequence is either interleave order (Pentium™ and X86) or linear order and is defined by LBO.

Output registers are provided and are controlled by FT mode pin. With FT mode pin, output registers can be programmed in either pipeline mode for very high frequency operation (133MHz) or flow-thru mode for reduced latency.

Byte write operation can be obtained through byte write enable (BWE) input combined with 4 individual byte write signals BW1-4. In addition, global write (GW) signal is also available to write all bytes at once.

Low power state (standby mode) can be obtained either through the assertion of ZZ signal or simply stop the clock (CLK). In standby mode, memory data are still retained. Low power design of 0.5mA standby are provided on L version.

The GS820V32 operates from a 3.3V power supply and all inputs and outputs are LVTTTL compatible. Separate output power (VDDQ) and ground (VSSQ) pins are employed to decouple output noise from internal circuit and VDDQ allow user the flexibility to employ lower output supply level like 2.5V. GS820V32's interface level is also compatible to 2.5V supply level.

The GS820V32 is implemented with GSI's high performance CMOS technology and is available in JEDEC standard 100 lead QFP (Q version) and TQFP (T version) package.

3

Pin configuration

Top view

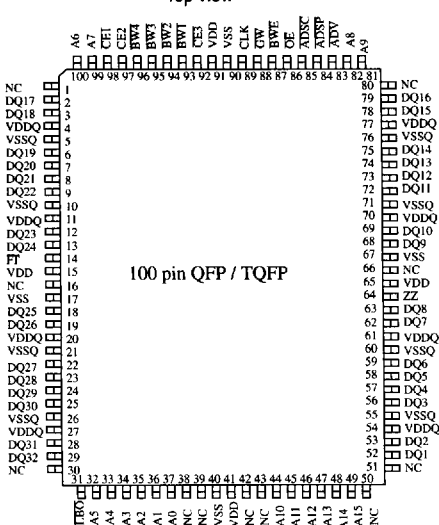

100 pin QFP / TQFP

A0-15	Address Inputs
CLK	Clock Input
BWE	Byte Write Enable
BWT, BW2 BW3, BW4	Byte Write. BWT for DQ1-8; BW2 for DQ9-16; BW3 for DQ17-24; BW4 for DQ25-32
GW	Global Write Enable
CE1, CE2, CE3	Chip Enable
OE	Output Enable
ADV	Burst Address advance
ADSP, ADSC	Address Status
DQ1-32	Data I/O
ZZ	Power down control
FT	Flow-Thru mode
LBO	Linear Burst mode
VDD	3.3V Power Supply
VSS	Ground
VDDQ	Output Power Supply, 2.375V to VDD (3.465Vmax)
VSSQ	Output Ground
NC	No Connect

GS820V32Q/T
4/5/6, 2.5V I/O, 2.0mA

64K x 32 Burst

80-133MHz (P/L)
66MHz (FT)

Functional Block Diagram

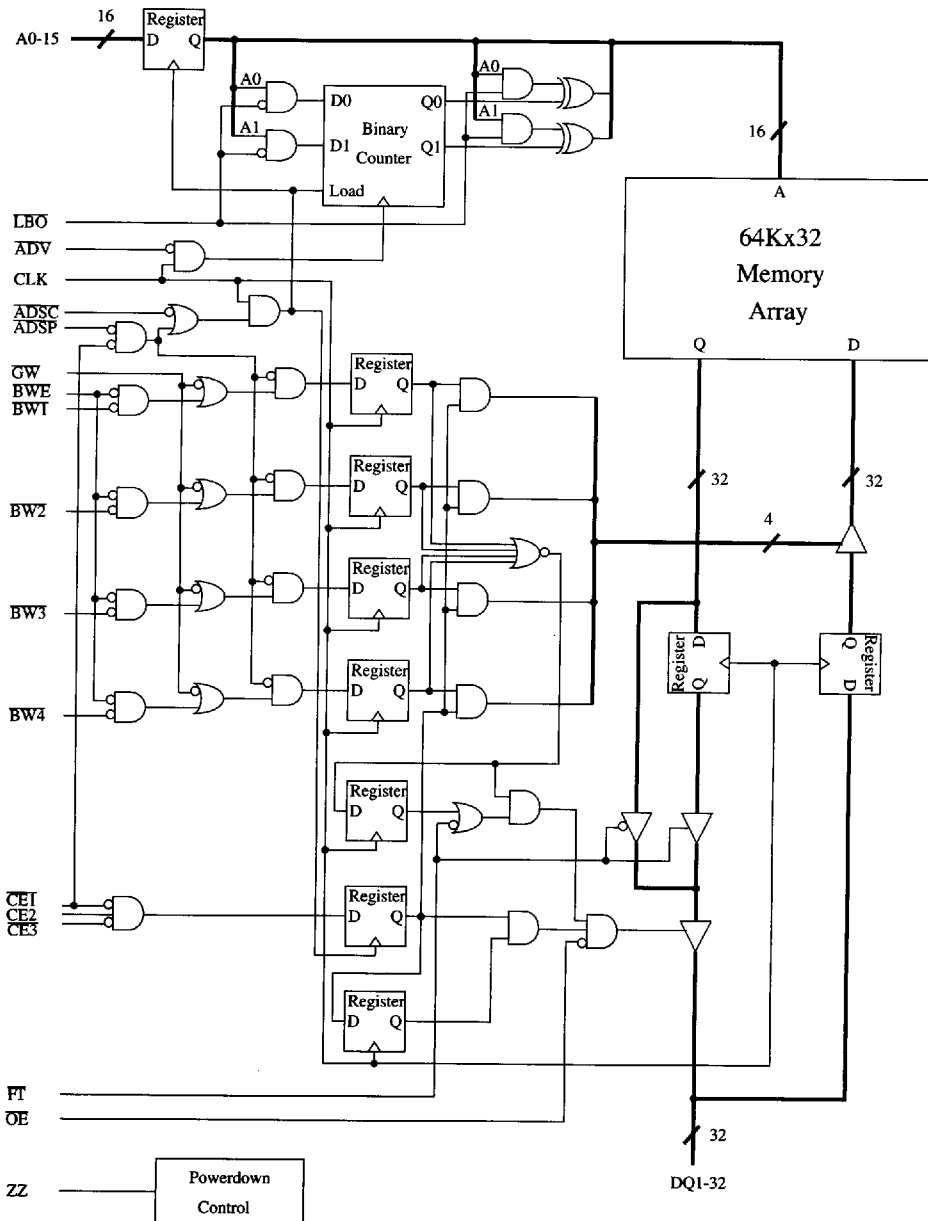

Mode pin function

LBO	Function
L	Linear Burst
H or NC	Interleaved Burst

FT	Function
L	Flow-Thru
H or NC	Pipeline

Power down control

ZZ	Function
L or NC	Active
H	Standby IDD=ISB

Note: There are pull up devices on LBO and FT pins and pull down device on ZZ pin, so those input pins can be unconnected and the chip will operate in the default states as specified in the above tables.

Linear Burst sequence

	A[1:0]	A[1:0]	A[1:0]	A[1:0]
1st address	00	01	10	11
2nd address	01	10	11	00
3rd address	10	11	00	01
4th address	11	00	01	10

The burst wrap around to initial state upon completion

Interleaved Burst sequence

	A[1:0]	A[1:0]	A[1:0]	A[1:0]
1st address	00	01	10	11
2nd address	01	00	11	10
3rd address	10	11	00	01
4th address	11	10	01	00

The burst wrap around to initial state upon completion

Byte Write Function

Function	SGW	BWE	BWI	BW2	BW3	BW4
Read	H	H	X	X	X	X
Read	H	L	H	H	H	H
Write all bytes	L	X	X	X	X	X
Write all bytes	H	L	L	L	L	L
Write byte 1	H	L	L	H	H	H
Write byte 2	H	L	H	L	H	H
Write byte 3	H	L	H	H	L	H
Write byte 4	H	L	H	H	H	L

Note: H=logic high, L=logic low, NC= no connect

Synchronous truth table

Cycle	Address used	CE1	CE2	CE3	ADSP	ADSC	ADV	BW \bar{x}
Deselect	none	H	X	X	X	L	X	X
Deselect	none	L	L	X	X	L	X	X
Deselect	none	L	X	H	X	L	X	X
Deselect	none	L	L	X	L	X	X	X
Deselect	none	L	X	H	L	X	X	X
Read, begin burst	external	L	H	L	L	X	X	X
Read, begin burst	external	L	H	L	H	L	X	H
Read, continue burst	next	X	X	X	H	H	L	H
Read, continue burst	next	H	X	X	X	H	L	H
Read, suspend burst	current	X	X	X	H	H	H	H
Read, suspend burst	current	H	X	X	X	H	H	H
Write, begin burst	external	L	H	L	H	L	X	L
Write, continue burst	next	X	X	X	H	H	L	L
Write, continue burst	next	H	X	X	X	H	L	L
Write, suspend burst	current	X	X	X	H	H	H	L
Write, suspend burst	current	H	X	X	X	H	H	L

- Note:**
1. X=don't care, H=logic high, L=logic low
 2. BW \bar{x} is the logic function of GW, BWE, BW1, BW2, BW3, BW4. See Byte Write Function table for detail.
 3. All inputs in the table must meet setup and hold on rising edge of CLK.

DQ Bus Control and Asynchronous OE

Cycle	OE	DQ
Read	L	Q
Read	H	Hi-Z
Write	X	Hi-Z; D
Deselect	X	Hi-Z

Note: On the write cycle that follows read cycle, OE need to be held high prior to the start of write cycle to tri-state DQ bus and allow data input to SRAM.

Absolute Maximum Ratings (Voltage reference to VSS=0V)

Parameter	Symbol	Rating	Unit
Supply Voltage	VDD	-0.5 to 4.6	V
Output Supply Voltage	VDDQ	-0.5 to VDD	V
CLK Input Voltage	VCLK	-0.5 to 6	V
Input Voltage	VIN	-0.5 to VDD+0.5 (≤ 4.6 V max.)	V
Output Voltage	VOUT	-0.5 to VDD+0.5 (≤ 4.6 V max.)	V
Power Dissipation	PD	1.5	W
Operating Temperature	Topr	0 to 70	°C
Storage Temperature	Tstg	-55 to 150	°C

Note: Permanent device damage may occur if Absolute Maximum Ratings are exceeded. Functional operation should be restricted to Recommended Operating Conditions. Exposure to higher than recommended voltages for extended periods of time could affect device reliability.

Recommended Operating Conditions (Voltage reference to VSS=0V)

(VDD=3.135V to 3.465V, Ta=0 70C)

Parameter	Symbol	Min.	Typ.	Max.	Unit
Supply Voltage	VDD	3.135	3.3	3.465	V
Output Supply Voltage	VDDQ	2.375	3.3	3.465	V
Input High Voltage	VIH	1.7	---	VDD+0.3	V
Input Low Voltage	VIL	-0.3	---	0.8	V

Note: Input overshoot voltage should be less than VDD+2V and not exceed 5ns.
Input undershoot voltage should be higher than -2V and not exceed 5ns.

Capacitance (Ta=25C, f=1MHz)

Parameter	Symbol	Test conditions	Typ.	Max.	Unit
Input Capacitance	CIN	VIN=0V	4	5	pF
Output Capacitance	COUT	VOUT=0V	6	7	pF

Note: These parameters are sampled and are not 100% tested.

GS820V32Q/T
4/5/6, 2.5V I/O, 2.0mA

64K x 32 Burst

80-133MHz (P/L)
66MHz (FT)

DC Characteristics (Voltage reference to VSS=0V)
(VDD=3.135V to 3.465V, Ta=0 to 70C)
(TA= -40 to +85C for Industrial Temperature Offering)

Parameter	Symbol	Test Conditions	133MHz		-4		-5		-6	
			Min	Max	Min	Max	Min	Max	Min	Max
Input Leakage Current (except ZZ, FT, LBO pins)	I _{IL}	V _{IN} = 0 to V _{DD}	-1uA	1uA	-1uA	1uA	-1uA	1uA	-1uA	1uA
ZZ Input Current	I _{INZZ}	V _{DD} ≥ V _{IN} ≥ V _{IH} 0V ≤ V _{IN} ≤ V _{IH}	-1uA -1uA	1uA 300uA	-1uA -1uA	1uA 300uA	-1uA -1uA	1uA 300uA	-1uA -1uA	1uA 300uA
Mode Input Current (FT & LBO pins)	I _{INM}	V _{DD} ≥ V _{IN} ≥ V _{IH} 0V ≤ V _{IN} ≤ V _{IH}	-300uA -1uA	1uA 1uA	-300uA -1uA	1uA 1uA	-300uA -1uA	1uA 1uA	-300uA -1uA	1uA 1uA
Output Leakage Current	I _{OL}	Output Disable, V _{OUT} = 0 to V _{DD}	-1uA	1uA	-1uA	1uA	-1uA	1uA	-1uA	1uA
Output High Voltage	V _{OH}	I _{OH} = - 8mA	2.4V		2.4		2.4V		2.4V	
Output Low Voltage	V _{OL}	I _{OL} = + 8mA		0.4V		0.4V		0.4V		0.4V

Parameter	Symbol	Test Conditions	133MHz		-4		-5		-6	
			0 to 70C	-40 to +85C	0 to 70C	-40 to +85C	0 to 70C	-40 to +85C	0 to 70C	-40 to +85C
Operating Supply Current (V _{DD} = man, E = V _{IH})	I _{DD}	Device Selected; All other inputs ≥ V _{IH} or ≤ V _{IL} Output open	240mA	245mA	210mA	215mA	180mA	185mA	125mA	155mA
Standby Current	I _{SB}	ZZ ≥ V _{DD} - 0.2V	2mA	7mA	2mA	7mA	2mA	7mA	2mA	7mA
Deselect Supply Current	I _{DD}	Device Selected; All other inputs ≥ V _{IH} or ≤ V _{IL}	80mA	85mA	70mA	75mA	60mA	65mA	50mA	55mA

AC Test Conditions

(VDD=3.135V to 3.465V, Ta=0 to 70C)

Parameter	Conditions
Input high level	V _{IH} =2.4V
Input low level	V _{IL} =0.4V
Input rise time	t _r =1V/ns
Input fall time	t _f =1V/ns
Input reference level	1.4V
Output reference level	1.4V
Output load	Fig. 1 & 2

- Note:**
1. Include scope and jig capacitance.
 2. Test conditions as specified with output loading as shown in Fig. 1 unless otherwise noted
 3. Output load 2 for t_{LZ}, t_{HZ}, t_{OLZ} and t_{OHZ}.

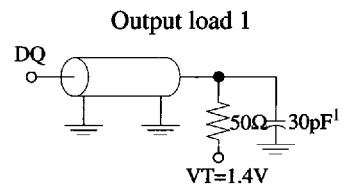

Fig. 1

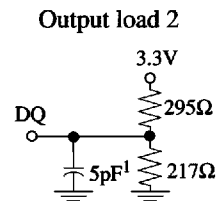

Fig. 2

AC Electrical Characteristics
(VDD=3.135V to 3.465V, Ta=0 to 70°C)

	Parameter	Symbol	-4		-5		-6		Unit
			Min	Max	Min	Max	Min	Max	
Pipeline	Clock to output valid	t _{KQ}	---	4.5	---	5	---	6	ns
	Clock to output invalid	t _{KQX}	2	---	2	---	2	---	ns
	Clock to output in Low-Z	t _{LZ} ²	2	---	2	---	2	---	ns
	Clock cycle time	t _{KC}	8.5	---	10	---	12.5	---	ns
Flow-Thru	Clock to output valid	t _{KQ}	---	12	NA ¹				ns
	Clock to output invalid	t _{KQX}	3	---					ns
	Clock to output in Low-Z	t _{LZ} ²	3	---					ns
	Clock cycle time	t _{KC}	15	---					ns
	Clock high time	t _{KH}	2	---	3	---	4	---	ns
	Clock low time	t _{KL}	2	---	3	---	4	---	ns
	Clock to output in Hi-Z	t _{HZ} ²	---	4	---	5	---	6	ns
	OE to output valid	t _{OE}	---	4	---	5	---	6	ns
	OE to output in Low-Z	t _{OLZ} ²	0	---	0	---	0	---	ns
	OE to output in Hi-Z	t _{OHZ} ²	---	4	---	5	---	6	ns
	Setup time	t _S	2.0	---	2.5	---	2.5	---	ns
	Hold time	t _H	0.5	---	0.5	---	0.5	---	ns
	ZZ setup time	t _{ZZS} ³	5	---	5	---	5	---	ns
	ZZ hold time	t _{ZZH} ³	1	---	1	---	1	---	ns
	ZZ recovery	t _{ZZR}	20	---	20	---	20	---	ns

- Note:
1. Flow-Thru mode is available in -4 bin only
 2. These parameters are sampled and are not 100% tested
 3. ZZ is a asynchronous signal. However, in order to be recognized on any given clock cycle, the signal must meet specified setup and hold time.

3

Read Cycle Timing (Pipeline)

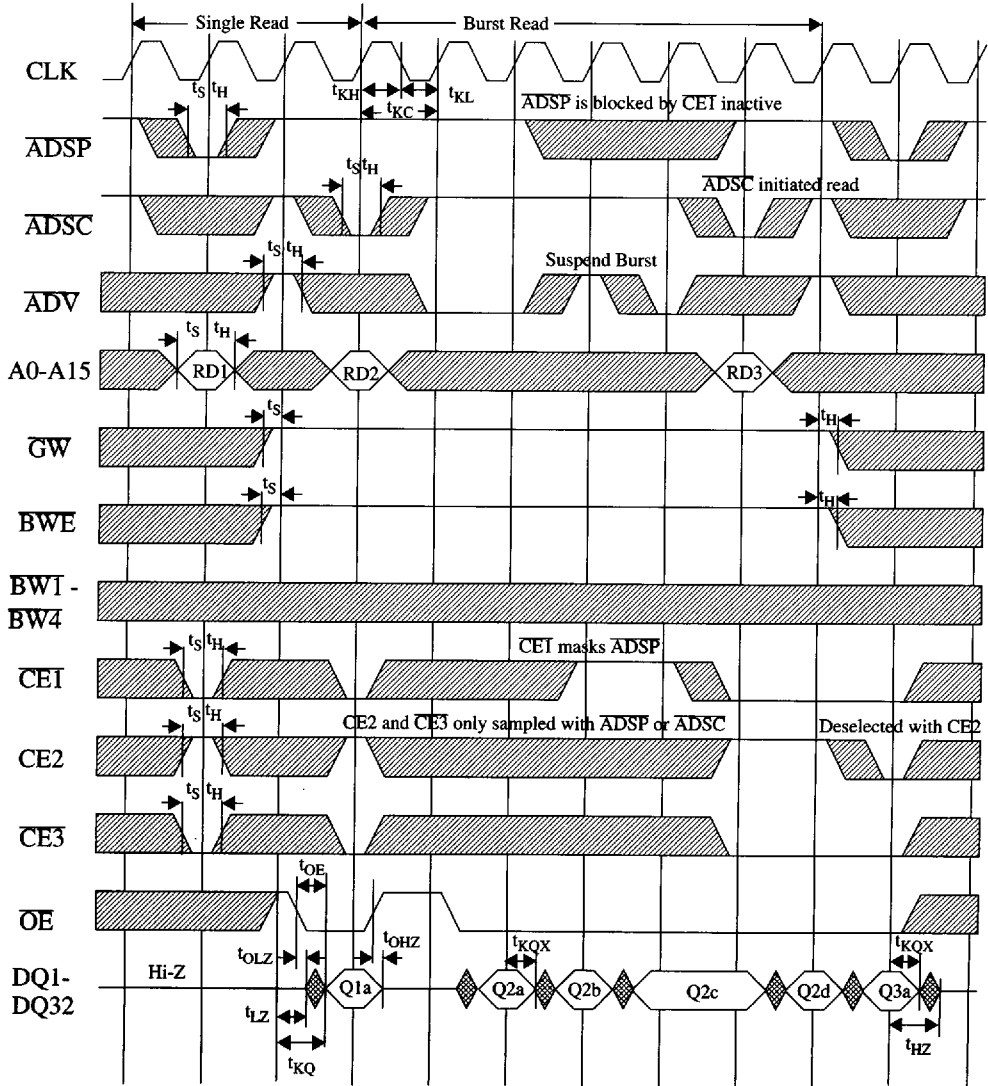

Write Cycle Timing

(This waveform can apply to both Pipeline and Flow-Thru modes)

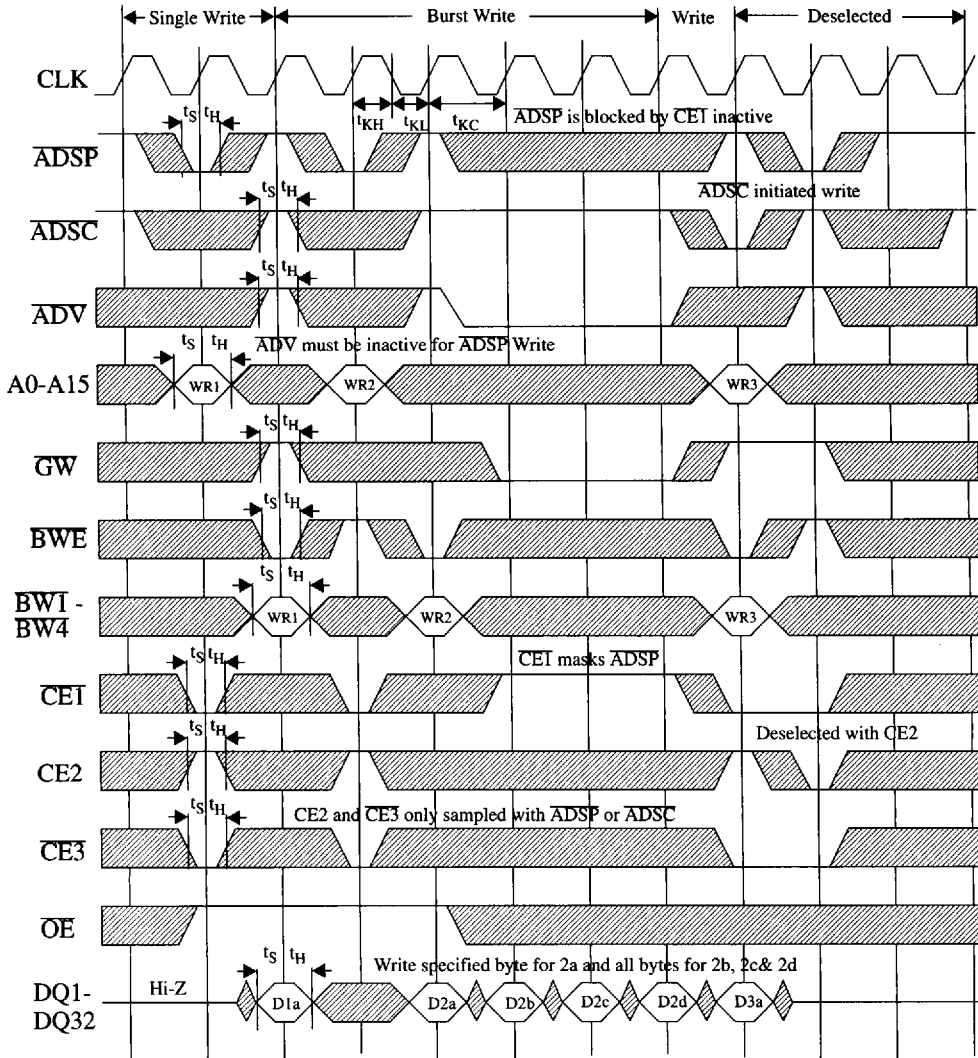

3

Read Cycle Timing (Flow-Thru)

3

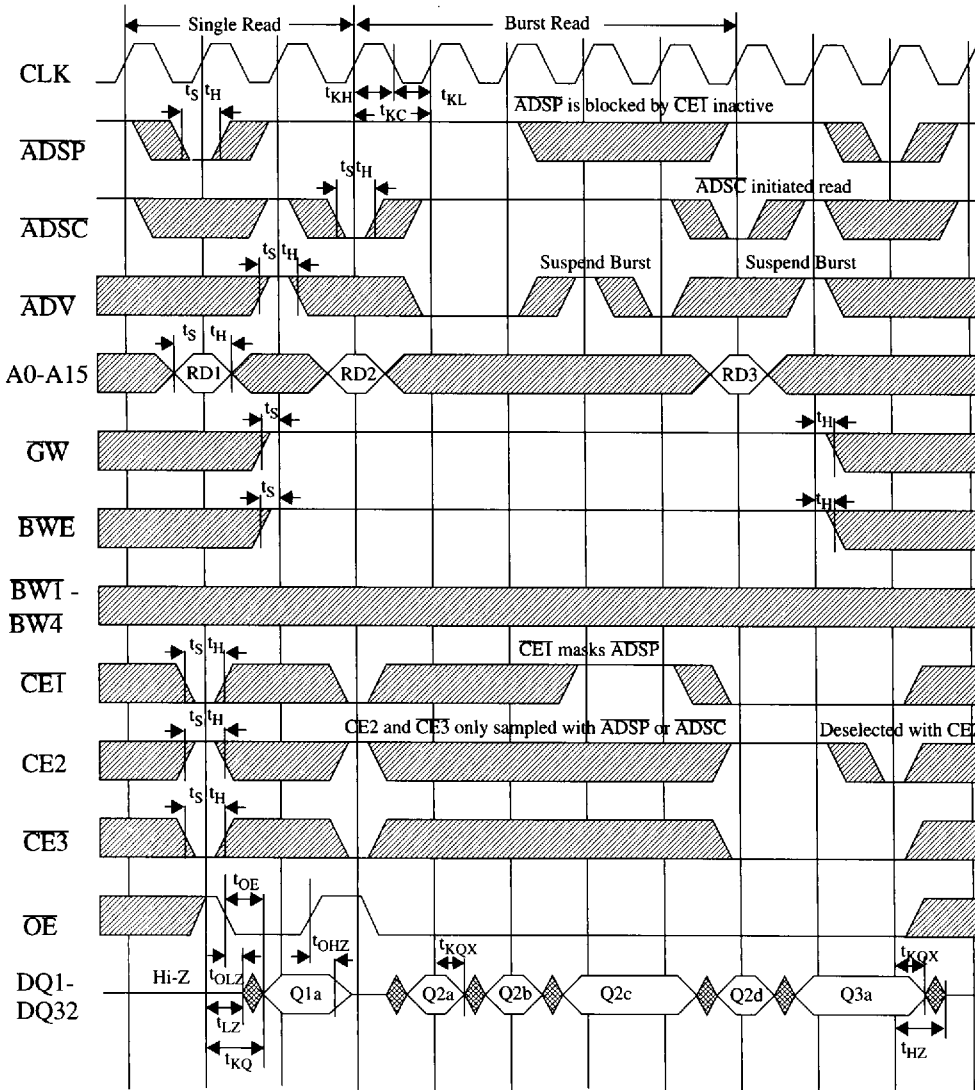

Read/Write Cycle Timing (Flow-Thru)

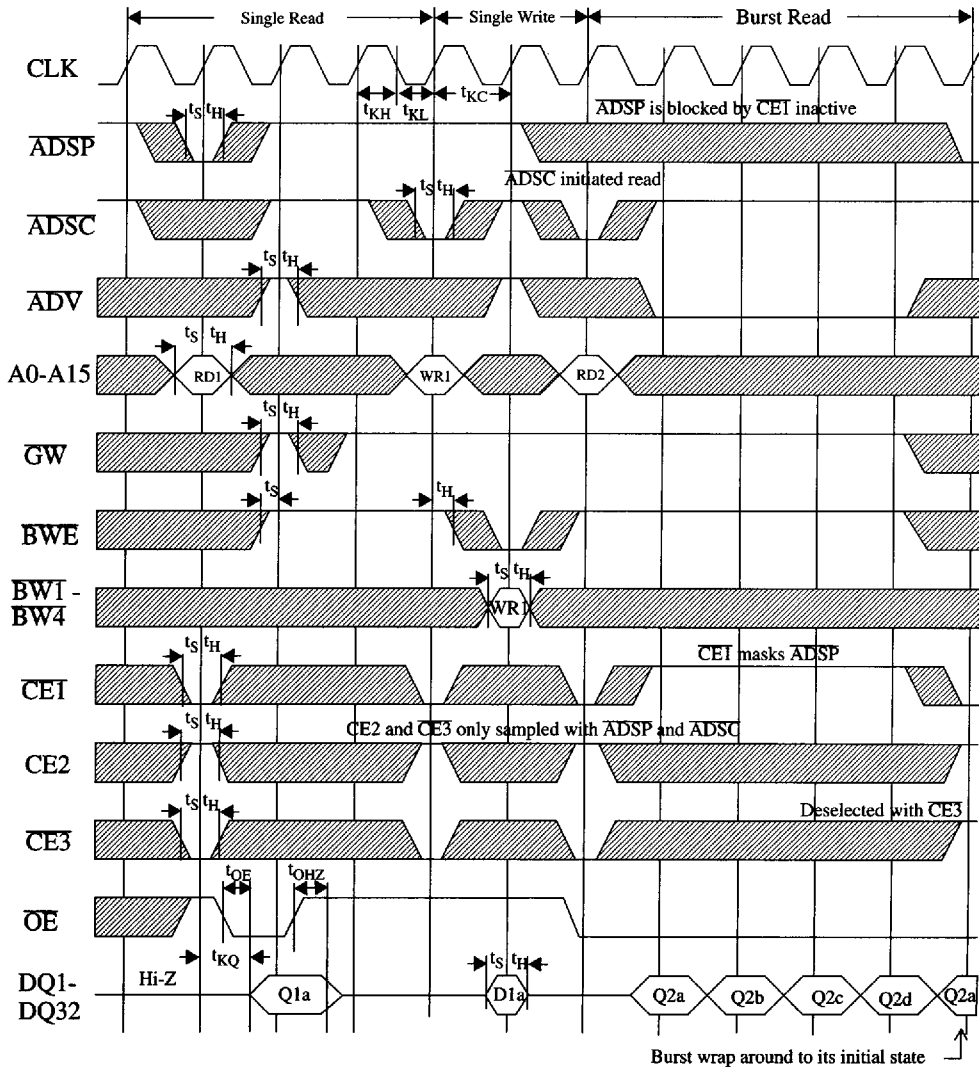

ZZ Timing

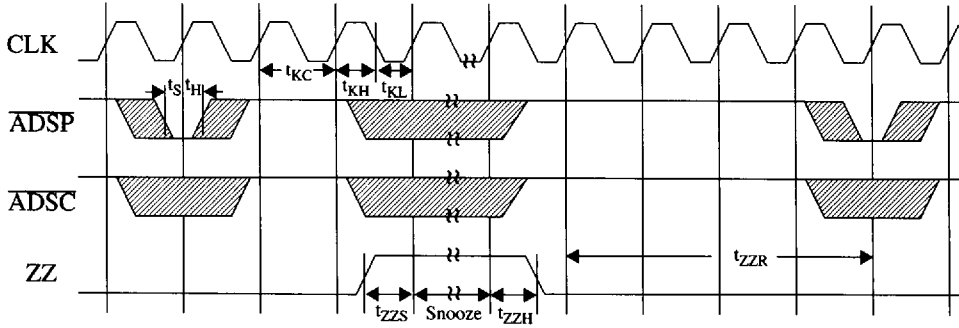

3

GS820V32Q/T
4/5/6, 2.5V I/O, 2.0mA

64K x 32 Burst

80-133MHz (P/L)
66MHz (FT)

Package Dimension

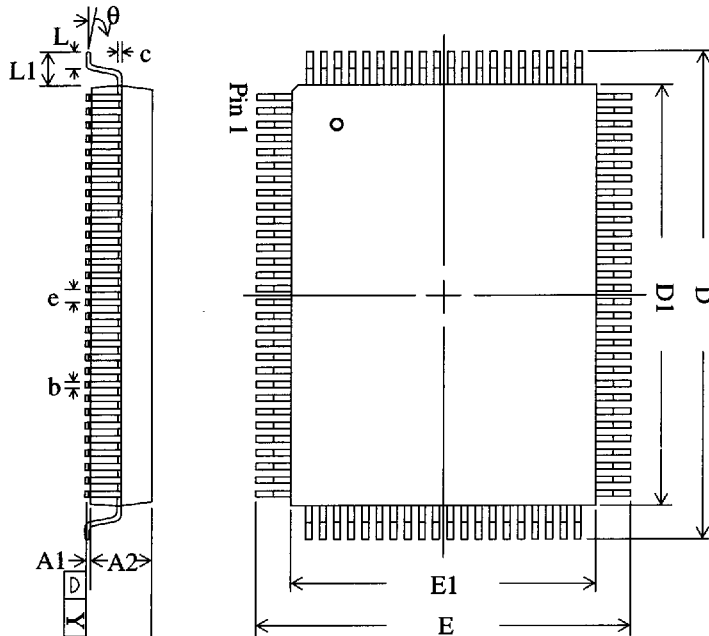

Symbol	Description	QFP (Q)			TQFP (T)		
		Min.	Nom.	Max	Min.	Nom.	Max
A1	Stand Off	0.25	0.35	0.45	0.05	0.10	0.15
A2	Body Thickness	2.55	2.72	2.90	1.35	1.40	1.45
b	Lead Width	0.20	0.30	0.40	0.20	0.30	0.40
c	Lead Thickness	0.10	0.15	0.20	0.09		0.20
D	Terminal Dimension	22.95	23.2	23.45	21.9	22.0	22.1
D1	Package Body	19.9	20.0	20.1	19.9	20.0	20.1
E	Terminal Dimension	17.0	17.2	17.4	15.9	16.0	16.1
E1	Package Body	13.9	14.0	14.1	13.9	14.0	14.1
e	Lead Pitch		0.65			0.65	
L	Foot Length	0.60	0.80	1.00	0.45	0.60	0.75
L1	Lead Length		1.60			1.00	
Y	Coplanarity			0.10			0.10
theta	Lead Angle	0°		7°	0°		7°

Note:

1. All dimensions are in millimeters (mm).
2. Package width and length do not include mold protrusion.

32 Pin SOI, 400 mil

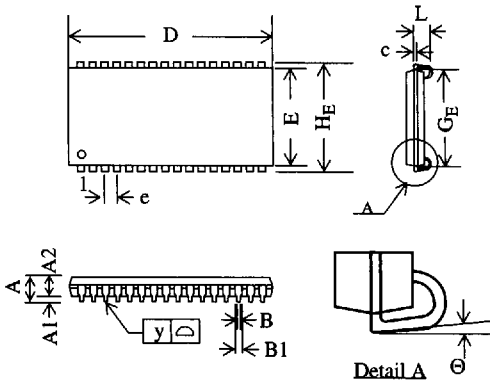

Symbol	Dimension in inch			Dimension in mm		
	min	nom	max	min	nom	max
A	-	-	0.146	-	-	3.70
A1	0.026	-	-	0.66	-	-
A2	0.105	0.110	0.115	2.67	2.80	2.92
B	0.013	0.017	0.021	0.33	0.43	0.53
B1	0.024	0.028	0.032	0.61	0.71	0.81
c	0.006	0.008	0.012	0.15	0.20	0.30
D	0.820	0.824	0.829	20.83	20.93	21.06
E	0.395	0.400	0.405	10.04	10.16	10.28
e	-	0.05	-	-	1.27	-
H _E	0.430	0.435	0.440	10.93	11.05	11.17
G _E	0.354	0.366	0.378	9.00	9.30	9.60
L	0.082	-	-	2.08	-	-
y	-	-	0.004	-	-	0.10
Θ	0°	-	10°	0°	-	10°

Note:

1. Dimension D & E do not include interlead flash
2. Dimension B1 does not include dambar protrusion / intrusion
3. Controlling dimension: inches

32 Pin SOI, 300 mil

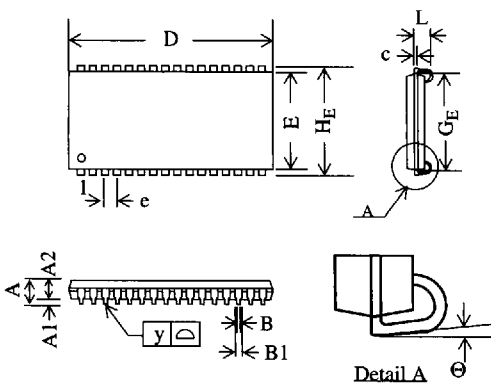

Symbol	Dimension in inch			Dimension in mm		
	min	nom	max	min	nom	max
A	0.125	-	0.148	3.175	-	3.76
A1	0.026	-	-	0.66	-	-
A2	0.095	0.100	0.105	2.41	2.54	2.67
B	0.013	0.017	0.021	0.33	0.43	0.53
B1	0.024	0.028	0.032	0.61	0.71	0.81
c	0.006	0.008	0.012	0.15	0.20	0.30
D	0.820	0.825	0.830	20.82	20.95	21.08
E	0.295	0.300	0.305	7.49	7.62	7.75
e	-	0.05	-	-	1.27	-
H _E	0.330	0.335	0.340	8.38	8.51	8.64
G _E	0.255	0.267	0.275	6.48	6.78	6.985
L	0.082	-	-	2.08	-	-
y	-	-	0.004	-	-	0.10
Θ	0°	-	10°	0°	-	10°

Note:

1. Dimension D & E do not include interlead flash
2. Dimension B1 does not include dambar protrusion / intrusion
3. Controlling dimension: inches

44 Pin TSOP type II, 400mil

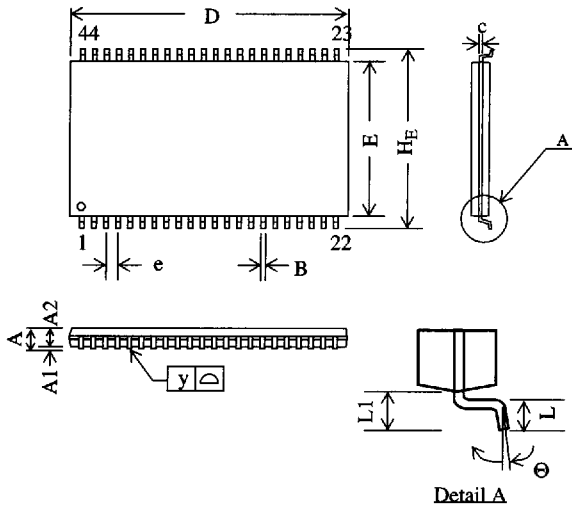

Symbol	Dimension in inch			Dimension in mm		
	min	nom	max	min	nom	max
A	-	-	0.047	-	-	1.20
A1	0.002	-	-	0.05	-	-
A2	0.037	0.039	0.041	0.95	1.00	1.05
B	0.01	0.014	0.018	0.25	0.35	0.45
c	-	0.006	-	-	0.15	-
D	0.721	0.725	0.729	18.31	18.41	18.51
E	0.396	0.400	0.404	10.06	10.16	10.26
e	-	0.031	-	-	0.80	-
HE	0.455	0.463	0.471	11.56	11.76	11.96
L	0.016	0.020	0.024	0.40	0.50	0.60
L1	-	0.031	-	-	0.80	-
y	-	-	0.004	-	-	0.10
θ	0°	-	5°	0°	-	5°

Note:

1. Dimension D & E do not include interlead flash
2. Dimension B does not include dambar protrusion / intrusion
3. Controlling dimension: mm

44 Pin SOL, 400 mil

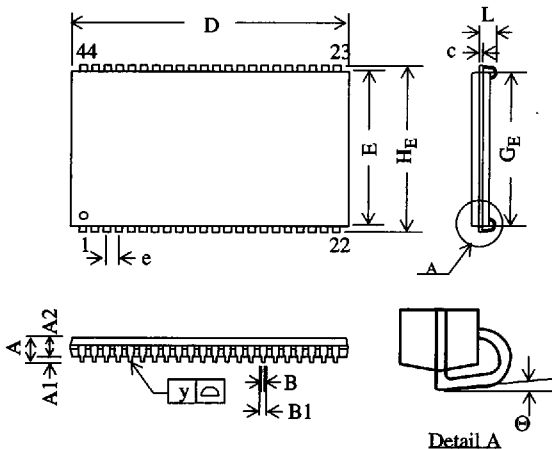

Symbol	Dimension in inch			Dimension in mm		
	min	nom	max	min	nom	max
A	-	-	0.148	-	-	3.759
A1	0.025	-	-	0.635	-	-
A2	0.105	0.110	0.115	2.667	2.794	2.921
B	-	0.018	-	-	0.457	-
B1	0.026	0.028	0.032	0.660	0.711	0.813
c	-	0.008	-	-	0.203	-
D	1.120	1.125	1.130	28.44	28.58	28.70
E	0.395	0.400	0.405	10.033	10.160	10.287
e	-	0.05	-	-	1.27	-
HE	0.435	0.440	0.445	11.049	11.176	11.303
GE	0.360	0.370	0.380	9.144	9.398	9.652
L	0.082	0.087	0.106	2.083	2.210	2.70
y	-	-	0.004	-	-	0.102
θ	0°	-	7°	0°	-	7°

Note:

1. Dimension D & E do not include interlead flash
2. Dimension B1 does not include dambar protrusion / intrusion
3. Controlling dimension: inches

36 Pin SOJ, 400 mil

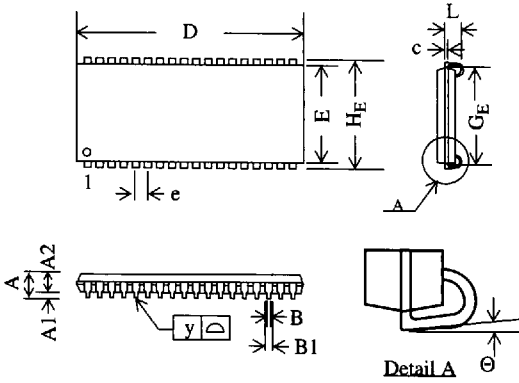

Symbol	Dimension in inch			Dimension in mm		
	min	nom	max	min	nom	max
A	-	-	0.146	-	-	3.70
A1	0.026	-	-	0.66	-	-
A2	0.105	0.110	0.115	2.67	2.80	2.92
B	0.013	0.017	0.021	0.33	0.43	0.53
B1	0.024	0.028	0.032	0.61	0.71	0.81
c	0.006	0.008	0.012	0.15	0.20	0.30
D	0.920	0.924	0.929	23.37	23.47	23.60
E	0.395	0.400	0.405	10.04	10.16	10.28
e	-	0.05	-	-	1.27	-
H _E	0.430	0.435	0.440	10.93	11.05	11.17
G _E	0.354	0.366	0.378	9.00	9.30	9.60
L	0.082	-	-	2.08	-	-
y	-	-	0.004	-	-	0.10
θ	0°	-	10°	0°	-	10°

Note:

1. Dimension D & E do not include interlead flash
2. Dimension B1 does not include dambar protrusion / intrusion
3. Controlling dimension: inches

Package Dimension

100 pin TQFP

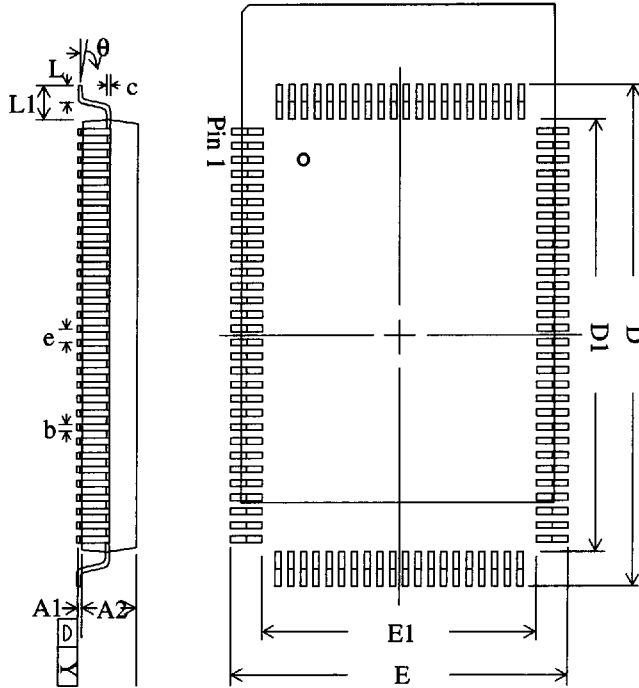

Symbol	Description	QFP (Q)			TQFP (T)		
		Min.	Nom.	Max	Min.	Nom.	Max
A1	Stand Off	0.25	0.35	0.45	0.05	0.10	0.15
A2	Body Thickness	2.55	2.72	2.90	1.35	1.40	1.45
b	Lead Width	0.20	0.30	0.40	0.20	0.30	0.40
c	Lead Thickness	0.10	0.15	0.20	0.09		0.20
D	Terminal Dimension	22.95	23.2	23.45	21.9	22.0	22.1
D1	Package Body	19.9	20.0	20.1	19.9	20.0	20.1
E	Terminal Dimension	17.0	17.2	17.4	15.9	16.0	16.1
E1	Package Body	13.9	14.0	14.1	13.9	14.0	14.1
e	Lead Pitch		0.65			0.65	
L	Foot Length	0.60	0.80	1.00	0.45	0.60	0.75
L1	Lead Length		1.60			1.00	
Y	Coplanarity			0.10			0.10
θ	Lead Angle	0°		7°	0°		7°

Note:

1. All dimensions are in millimeters (mm).
2. Package width and length do not include mold protrusion.